



AGENDA – Engineering and Construction Committee

Thursday, January 16, 2025 6:00 PM

Committee Members

J. Fennell, Chair
D. Bouckaert
D. Novotny
F. Saverino
J. Zay

- I. Roll Call
- II. Approval of the November 21, 2024, Engineering & Construction Committee Minutes

RECOMMENDED MOTION: To approve the Minutes of the November 21, 2024, Engineering & Construction Committee Meeting of the DuPage Water Commission.

- III. Report of Status of Operations and Construction
- IV. **Resolution R-04-25:** A Resolution Approving the Purchase and Installation of Additional Security Cameras (**Schneider Electric – \$128,308.00**)
- V. **Resolution R-06-25:** A Resolution Authorizing the General Manager to Purchase Material and Labor Services for the High-Lift Pump Motors including Ancillary Equipment (**WEG Electric – Not-To-Exceed \$100,000.00**)
- VI. **Resolution R-07-25:** A Resolution Authorizing Classen, White and Associates to Perform Surveying Services in Relation to the Commission’s Hydraulic Model (**Estimated Cost of \$34,019.00**)
- VII. **Resolution R-09-25:** A Resolution Approving and Ratifying Certain Work Authorization Orders Under Quick Response Contract QR-12/21 (**WAO No. 030 – Rossi Contractors, Inc – Estimated Expense of \$123,200.00**)
- VIII. **Resolution R-10-25:** A Resolution Approving and Ratifying Certain Work Authorization Orders Under Quick Response Contract QR-12/21 (**WAO No. 029 – Rossi Contractors, Inc. – Not-to-Exceed \$91,920.00**)
- IX. **Resolution R-11-25:** A Resolution Approving Task Order No. 5 under a Maser Contract with Burns & McDonnell Engineering Co., Inc. (**Not-To-Exceed \$3,613,698.00**)
- X. **Resolution R-12-25:** A Resolution Authorizing the General Manager to Purchase Frames and Lids from a Sole Source Manufacturer (**Neenah Foundry – Cost Not-to-Exceed \$48,867.00**)

- XI. **Resolution R-13-25:** A Resolution Authorizing the General Manager to Pre-Purchase Three, 48” Butterfly Valves (**Val-Matic Valve and Manufacturing Corp. – Cost Not-to-Exceed \$176,126.00**)

RECOMMENDED MOTION: To recommend approval of Items 2 through 9 of the Engineering and Construction Committee Report section of the Commission meeting agenda.

- XII. Other Business

- XIII. Adjournment

Agendas\Engineering\2025\Eng2501.docx

**Minutes of a Meeting
of the**

ENGINEERING & CONSTRUCTION COMMITTEE

DuPage Water Commission
600 E. Butterfield Road, Elmhurst, Illinois

November 21, 2024

Chairman Fennell called the meeting to order at 6:00 P.M.

Committee members in attendance: D. Bouckaert, J. Fennell, D. Novotny, F. Saverino and J. Zay

Committee members absent: None

Also in attendance: C. Bostick, D. Cuvalo, J. Loster, D. Panaszek and M. Weed

Commissioner Bouckaert moved to approve the Minutes of the September 19, 2024, Engineering & Construction Committee Meeting of the DuPage Water Commission. Motion seconded by Commissioner Saverino and unanimously approved by a Voice Vote.

Manager of Water Operations Bostick and Engineering Manager Loster provided a report of the ongoing Operations and Maintenance activities as listed in the Report of Status of Operations and Board Action Items and provided a report on the Status of Capital Construction, Capital Engineering and other Improvement Projects.

Manager of Water Operations Bostick advised the Committee that preventative maintenance and repairs are being performed as scheduled or as needed.

Regarding R-70-24, Manager of Water Operations Bostick advised the Committee that this action appears on the agenda to approve a 1-year contract extension with Meccon Industries, Inc. to perform pipefitting, heavy machinery and equipment rigging work. Manager of Water Operations Bostick advised the Committee that staff is gearing up and is working with Meccon to replace several 30" butterfly valves and air release/vacuum valves on the DuPage Pump Station East Discharge Header as well as remove and replace the 30" cone valve which operates as the pump control valve on HLP-9. Staff is working towards performing this work during the low demand period in Winter of 24/25.

Manager of Water Operations Bostick updated the Committee regarding the City of Chicago's transition from a blended phosphate treatment to an orthophosphate treatment. He indicated that staff have provided the Cornwell Engineering Group report to Commission Customers with recommendations to help DWC Staff and Customers ensure that proper measures are being taken before, during and after the City's transition of treatment methodology. Manager of Water Operations Bostick also advised the City has reported, due to unidentified construction issues, the commencement of transition period has been delayed from the original October 2024 date to sometime in December 2024.

Manager of Water Operations Bostick advised the Committee that Commission staff continue to discuss with Department of Water Management staff the items identified in the Lexington Pump Station Condition Assessment, however the progress of work being performed is slow. Manager of

Water Operations Bostick advised the Committee that the City's SCADA View Node has again returned to a state of failure.

Regarding the ongoing discussions on alternate water sources, Manager of Water Operations Bostick advised the Committee that Christopher B. Burke Engineering, Ltd. (CBBEL) finalized the development of the preliminary site plan for the Northbrook property including preliminary site stormwater management strategies, grading and utility plans. Manager of Water Operations Bostick advised the Committee that General Manager May has met recently with the Village of Northbrook and will report to the Commission during the regular Commission meeting.

Manager of Water Operations Bostick advised the Committee that exploration excavation on the 72-inch steel East Discharge piping of the DuPage Pump Station has been completed and determined that corrosion was not evident due to complete encasement of the pipe in a concrete envelope at the time of original construction.

Regarding R-57-24, Manager of Water Operations Bostick advised the Committee that this action appears on the agenda to approve replacement of certain meter station entrance doors. Manager of Water Operations Bostick informed the Committee that these particular doors date back to original construction and the expense of the replacements are due to custom manufacturing to meet existing structural and architectural elements.

Manager of Water Operations Bostick reported on the progress of the SCADA Replacement Project and stated that the work continues to progress on schedule and within budget, and the focus is now on Factory Acceptance Testing for Remote Telemetry Units for meter stations.

Regarding the Request for Board Action listed on the agenda, Manager of Water Operations Bostick advised the Committee that this action appears on the agenda to provide authorization to the General Manager to execute an agreement with an Alternative Retail Electricity Supplier should a favorable arrangement become available between now and the January 2025 Commission meeting.

Engineering Manager Loster reported on the Emergency Generation System Modifications Project (PSD-10/22) and stated that all work has now been completed and that resolution R-71-24 on the agenda represents a final change order. He noted that the associated cost of \$7,645.03 based on completion of the work on a time and material basis was a significant reduction from the initial proposal of more than \$18,000. Engineering Manager Loster stated that this change order will bring the final project cost to approximately 2.8% over the amount awarded and, with all work now complete no additional costs will be incurred and the 24-month warranty period has begun. He also noted that \$50,000 in retainage is currently being held.

Engineering Manager Loster also stated that work is ongoing for the annual cathodic protection improvements on the TW-2 pipeline and is approximately 50% complete. He noted that recent weather has caused some schedule delays but that the work is still scheduled to be completed around the end of the month or shortly into December.

Engineering Manager Loster introduced Ordinance O-8-24 which appears on the agenda, to approve ingress/egress and utility easements related to a fifth connection for the Village of Lombard,

conversations for which date back to 2021. He noted that an additional easement will be needed in the future for the actual delivery parcel that the Village of Lombard is in the process of purchasing, however, because that parcel is not adjacent to the public right of way, the easements represented in O-8-24 are required to place a feeder main through a private property, from the public right of way to the proposed delivery parcel.

Engineering Manager Loster provided a WaterLink update, indicating that the Phase II Engineering effort is approximately 50% complete. He noted that the 75% plan documents have been reviewed by Commission staff with the design team proceeding with development of the 90% plan documents. Engineering Manager Loster also noted that recent progress has been made with ComEd in having received conceptual approval of the general pipe alignment through their corridor. He also stated that six statements of qualifications were submitted in response to the request for qualifications issued by the Commission for phase III construction engineering services, with the intent to hear presentations from two of the shortlisted firms in early December to serve in a Program Manager role, in addition to providing construction engineering services on the Book Road bid package. Engineering Manager Loster indicated that the goal is to have an associated contract for consideration by the Board in January. Additionally, Engineering Manager Loster noted that a recent meeting was held with EPA staff, design team staff, DWC staff and representatives from the WaterLink communities to discuss WIFIA requirements, which will serve as a major funding source on the project. He noted that the purpose of the call was to ensure that all bid/construction processes are setup in a manner that is compliant with WIFIA requirements in addition to receiving confirmation of a Build America Buy America (BABA) waiver, which will result in a significant reduction in project costs.

Chairman Fennell inquired with the Committee if there were any further questions regarding the action items. Hearing none, Commissioner Bouckaert moved to recommend approval of items 2 through 6 of the Engineering and Construction Committee portion of the Commission Agenda (Items IV through VIII on the Engineering and Construction Committee Agenda). Seconded by Commissioner Saverino and unanimously approved by a Voice Vote.

Commissioner Fennell asked the Committee if any other business or other items to be discussed. Hearing none, and with no other items coming before the Committee, Commissioner Bouckaert moved to adjourn the meeting at 6:18 P.M. Seconded by Commissioner Saverino and unanimously approved by a Voice Vote.



MEMORANDUM

To: Paul May – General Manager

From: Chris Bostick – Manager of Water Operations
Jeff Loster – Manager of Engineering

Mike Weed – Operations & Instrumentation Supervisor
Dariusz Panaszek – Pipeline & Remote Facilities Supervisor
Denis Cuvalo – Systems Engineer and Information Technology Supervisor

Date: 12/12/2024

Subject: Status of Operations, Engineering and Construction

Operations Overview

The Commission's sales for November 2024 were a total of 1.88 billion gallons. This represents an average daily demand of 62.5 million gallons per day (MGD), which is lower than the November 2023 average day demand of 66.2 MGD. The maximum day demand was 66.5 MGD recorded on November 27, 2024, which is lower than the November 2023 maximum day demand of 70.0 MGD. The minimum day flow was 58.3 MGD.

The recorded total precipitation for November 2024 was 3.66 inches compared to .89 inches for November 2023. The level of Lake Michigan for November 2024 is 578.55 (Feet International Great Lakes Datum (IGLD) 1985) compared to 578.77 (Feet IGLD 1985) for November 2023.

DuPage Operations & Instrumentation Maintenance and Construction Overview

The 2024 Meter Testing Program is in process and 84% complete.

The DuPage Pumping Station Reservoir Influent and Effluent Valves are scheduled to be rebuilt the week of December 16th.

High Lift Pump No. 2 motor was repaired and is back in service.

Preventive maintenance on HLP's 1-10 electromechanical safety relays was performed the week of December 9th.

City of Chicago Water Treatment Modifications

The City of Chicago's transition from their current blended phosphate to phosphoric acid is reportedly underway to optimize the control of lead and copper release through household plumbing. Staff have shared this updated information with all of DWC Customers.

DWC staff continues monitoring certain water quality parameters to follow the progress during the City's transition of the treatment technique. The monitoring program will continue through Spring of 2025.

Lexington Operations and Maintenance Overview

No Change: Investigations continue, and additional proposals are being sought for the installation of vibration analysis instrumentation; proposals will be brought forth for Board consideration in the near future.

No Change: Commission staff have informed DWM staff that the Lexington SCADA node is once again in failure mode. DWM reports that they will continue to troubleshoot their SCADA system deficiencies to identify the root cause of the ongoing issues.

Alternate Water Source

Staff will be engaging with the Village of Northbrook regarding tree removal permitting and contractors to perform tree removal and site cleanup of fly-dumped materials where the work will be performed once the ground has frozen and become more stable.

Pipeline & Remote Facilities Maintenance Overview

Pipeline and Remote Facilities staff continue to inspect and perform preventative maintenance and corrective work as needed.

Pipeline staff and DeLasCasas CP, LLC are performing testing and maintenance on the galvanic cathodic protection systems on selected feeder mains and meter station piping.

Pipeline staff and Ferguson Industrial are inspecting selected system valves on transmission mains and performing repairs as needed. The work is being performed in preparation for the future main water connection for the upcoming WaterLink pipeline project.

The Pipeline staff continue working with Rossi Contractors, Inc. on Contract TW-5 by installing sacrificial anode ground beds on the West Transmission Main.

SCADA & Information Technology Overview

The SCADA Replacement Project (Contract PSD-9/21) is ongoing. The DWC campus control panel replacement has been completed with final site acceptance testing and open items work being completed. The Factory Acceptance Test (FAT) for the remote site control panels including Lexington, Tank Sites, Meters Stations, and ROV's has been completed. Action items from the FAT as well as additional testing and preparation is taking place throughout the month of December. Following the completion of these items, Commission and Concentric staff will begin replacing RTU panels at the remote sites. The inspection and maintenance of all remote site antenna systems is underway and

roughly 80% complete. Replacement of the fiber network for the DWC campus is anticipated to begin late this Fall following the completion of all control and network upgrades with the addition of a new duct bank to complete a ring topology for the new fiber network. The Access Control security system upgrade is underway, anticipated to be complete wither end of December or early January.

Engineering & Capital Improvement Program Overview

The Commission’s annual Cathodic Protection Project on the TW-2 pipeline is nearing completion. Work is being performed by Rossi Contractors and only restoration and a small amount of horizontal directional drilling remain in order to complete the work.

Design of a Joint Facility (Metering Station and Pressure Adjusting Station) at Lombard’s fifth connection point remains ongoing. Design will be completed in 2025 with construction to follow.

WaterLink Communities (Montgomery/Oswego/Yorkville)

The Phase II engineering effort remains ongoing and is approximately 60% complete. Preliminary field work (utility potholing, soil borings, etc.) is nearly complete, with remaining work in the ComEd corridor underway.

Development of 90% plans has recently been completed, with all documents having been submitted to Commission Staff for review. During this review period, the 90% documents will also be submitted to the 28 agencies having some form of permitting jurisdiction on the project. The permitting phase is generally expected to last approximately 60-90 days for most agencies. Coordination with these permitting agencies and the WaterLink Communities remains ongoing to make sure any design changes are quickly and accurately represented to all impacted parties.

The acclimation phase of the corrosion control treatment study, performed by the Cornwell Engineering Group, is nearing completion with associated reports having been submitted to the Illinois Environmental Protection Agency (IEPA) for review/comment earlier this month. Upon completion of the acclimation phase, water from the Jardine Water Purification Plant will then be recirculated through the harvested pipe segments to simulate the transition in water sources and further analysis will be performed. This study is required by the IEPA and is expected to be completed by November 2025.

Commission Staff also recently requested presentations from two engineering firms in response to submitted Statements of Qualifications for construction engineering services and to fulfill a “Corridor Manager” role on the WaterLink Project. Upon discussion of both presentations, Commission Staff is prepared to recommend a contract for the Corridor Manager role and to provide construction engineering services on the “Book Road” bid package in January. Additional contracts associated with the construction phase are anticipated to be brought for consideration in January as well.

Attachments

1. DuPage Laboratory Bench Sheets for November 2024
2. Water Sales Analysis 01-May-2020 to 30-November-2024
3. DuPage Water Commission Chart Sales vs. Historical Average
4. DuPage Water Commission Chart Sales vs. Allocation
5. WaterLink Status Report

DU PAGE WATER COMMISSION
WATER SALES ANALYSIS

01-May-92 TO 30-Nov-24

PER DAY AVERAGE 77,919,162

MONTH	SALES TO CUSTOMERS (GALLONS)	PURCHASES FROM CHICAGO (GALLONS)	GALLONS BILLED %	BILLINGS TO CUSTOMERS	BILLINGS FROM CHICAGO	DOCUMENTED WATER USE (2)	DOCUMENTED COMMISSION WATER USE %	TOTAL ACCOUNTED FOR %	DWC OPER. & MAINT. RATE (3)	CHGO RATE
May-20	2,084,924,000	2,141,838,951	97.34%	\$10,362,072.28	\$8,513,809.83	376,100	0.02%	97.36%	\$4.97	\$3.975
Jun-20	2,522,634,000	2,596,146,493	97.17%	\$12,537,490.98	\$10,571,508.52	731,078	0.03%	97.20%	\$4.97	\$4.072
Jul-20	2,782,507,000	2,872,440,835	96.87%	\$13,829,059.79	\$11,696,579.08	647,000	0.02%	96.89%	\$4.97	\$4.072
Aug-20	3,078,522,000	3,180,137,701	96.80%	\$15,300,254.34	\$12,949,520.72	3,694,350	0.12%	96.92%	\$4.97	\$4.072
Sep-20	2,427,570,000	2,510,646,051	96.69%	\$12,065,022.90	\$10,223,350.72	1,148,848	0.05%	96.74%	\$4.97	\$4.072
Oct-20	2,143,671,000	2,203,255,879	97.30%	\$10,654,044.87	\$8,971,657.94	748,000	0.03%	97.33%	\$4.97	\$4.072
Nov-20	1,897,985,000	1,957,960,123	96.94%	\$9,432,985.45	\$7,972,813.62	200,026	0.01%	96.95%	\$4.97	\$4.072
Dec-20	1,955,711,000	2,027,160,874	96.48%	\$9,719,883.67	\$8,254,599.08	348,955	0.02%	96.49%	\$4.97	\$4.072
Jan-21	1,988,344,000	2,040,857,402	97.43%	\$9,882,069.68	\$8,310,371.34	205,828	0.01%	97.44%	\$4.97	\$4.072
Feb-21	1,915,366,000	1,971,858,620	97.14%	\$9,519,369.02	\$8,029,408.30	290,224	0.01%	97.15%	\$4.97	\$4.072
Mar-21	1,986,888,000	2,055,661,022	96.65%	\$9,874,833.36	\$8,370,651.68	512,237	0.02%	96.68%	\$4.97	\$4.072
Apr-21	1,959,759,000	2,010,756,459	97.46%	\$9,740,002.23	\$8,187,800.30	1,013,926	0.05%	97.51%	\$4.97	\$4.072
May-21	2,331,364,000	2,401,447,849	97.08%	\$11,586,879.08	\$9,778,695.64	1,625,835	0.07%	97.15%	\$4.97	\$4.072
Jun-21	2,646,312,000	2,727,518,236	97.02%	\$13,152,170.64	\$11,226,465.06	872,815	0.03%	97.05%	\$4.97	\$4.116
Jul-21	2,661,520,000	2,750,318,994	96.77%	\$13,227,754.40	\$11,320,312.98	772,815	0.03%	96.80%	\$4.97	\$4.116
Aug-21	2,736,795,000	2,818,422,046	97.10%	\$13,601,871.15	\$11,600,625.14	458,555	0.02%	97.12%	\$4.97	\$4.116
Sep-21	2,616,212,000	2,698,022,374	96.97%	\$13,002,573.64	\$11,105,060.09	1,237,080	0.05%	97.01%	\$4.97	\$4.116
Oct-21	2,128,141,000	2,179,013,387	97.67%	\$10,576,860.77	\$8,968,819.10	396,147	0.02%	97.68%	\$4.97	\$4.116
Nov-21	1,896,311,000	1,961,815,221	96.66%	\$9,424,665.67	\$8,074,831.45	462,613	0.02%	96.68%	\$4.97	\$4.116
Dec-21	1,950,793,000	2,010,917,641	97.01%	\$9,695,441.21	\$8,276,937.01	382,031	0.02%	97.03%	\$4.97	\$4.116
Jan-22	2,046,043,000	2,110,214,643	96.96%	\$10,168,833.71	\$8,685,674.26	621,078	0.03%	96.99%	\$4.97	\$4.116
Feb-22	1,879,376,000	1,935,513,559	97.10%	\$9,340,498.72	\$7,966,573.81	247,750	0.01%	97.11%	\$4.97	\$4.116
Mar-22	1,990,472,000	2,061,912,643	96.54%	\$9,892,645.84	\$8,486,832.44	459,838	0.02%	96.56%	\$4.97	\$4.116
Apr-22	1,935,992,000	1,981,414,298	97.71%	\$9,621,880.24	\$8,155,501.25	285,652	0.01%	97.72%	\$4.97	\$4.116
May-22	2,276,513,000	2,344,221,635	97.11%	\$11,792,337.34	\$9,648,816.25	5,698,667	0.24%	97.35%	\$5.18	\$4.116
Jun-22	2,682,480,000	2,772,533,130	96.75%	\$13,895,246.40	\$11,982,888.19	690,925	0.02%	96.78%	\$5.18	\$4.322
Jul-22	2,804,661,000	2,892,532,635	96.96%	\$14,528,143.98	\$12,501,526.05	883,858	0.03%	96.99%	\$5.18	\$4.322
Aug-22	2,688,224,000	2,772,533,130	96.96%	\$13,925,000.32	\$11,982,888.19	906,806	0.03%	96.99%	\$5.18	\$4.322
Sep-22	2,415,535,000	2,474,643,822	97.61%	\$12,512,471.30	\$10,695,410.60	1,021,063	0.04%	97.65%	\$5.18	\$4.322
Oct-22	2,153,410,000	2,220,050,683	97.00%	\$11,154,663.80	\$9,595,059.05	2,891,786	0.13%	97.13%	\$5.18	\$4.322
Nov-22	1,919,552,000	1,979,550,491	96.97%	\$9,943,279.36	\$8,555,617.22	1,008,092	0.05%	97.02%	\$5.18	\$4.322
Dec-22	2,071,113,000	2,123,449,660	97.54%	\$10,728,365.34	\$9,177,549.43	552,389	0.03%	97.56%	\$5.18	\$4.322
Jan-23	2,014,750,000	2,060,255,805	97.79%	\$10,436,405.00	\$8,904,425.59	337,423	0.02%	97.81%	\$5.18	\$4.322
Feb-23	1,835,597,000	1,883,158,917	97.47%	\$9,508,392.46	\$8,139,012.84	529,206	0.03%	97.50%	\$5.18	\$4.322
Mar-23	1,971,974,000	2,026,257,691	97.32%	\$10,214,825.32	\$8,757,453.41	306,690	0.02%	97.34%	\$5.18	\$4.322
Apr-23	1,962,197,000	2,010,451,747	97.60%	\$10,164,180.46	\$8,689,172.45	349,596	0.02%	97.62%	\$5.18	\$4.322
May-23	2,474,377,000	2,540,440,833	97.40%	\$13,336,892.03	\$10,979,785.28	684,441	0.03%	97.43%	\$5.39	\$4.322
Jun-23	2,971,436,000	3,043,540,086	97.63%	\$16,016,040.04	\$13,814,628.45	678,930	0.02%	97.65%	\$5.39	\$4.539
Jul-23	2,567,425,000	2,639,887,376	97.26%	\$13,838,420.75	\$11,982,448.80	1,047,600	0.04%	97.29%	\$5.39	\$4.539
Aug-23	2,708,945,000	2,773,069,509	97.69%	\$14,601,213.55	\$12,586,962.50	832,992	0.03%	97.72%	\$5.39	\$4.539
Sep-23	2,406,858,000	2,471,708,096	97.38%	\$12,972,964.62	\$11,219,083.05	753,904	0.03%	97.41%	\$5.39	\$4.539
Oct-23	2,071,291,000	2,116,545,770	97.86%	\$11,164,258.49	\$9,607,001.25	1,034,131	0.05%	97.91%	\$5.39	\$4.539
Nov-23	1,902,725,000	1,957,768,374	97.19%	\$10,255,687.75	\$8,886,310.65	809,342	0.04%	97.23%	\$5.39	\$4.539
Dec-23	1,972,754,000	2,031,158,416	97.12%	\$10,633,144.06	\$9,219,428.05	2,329,064	0.11%	97.24%	\$5.39	\$4.539
Jan-24	2,058,390,000	2,131,445,175	96.57%	\$11,094,722.10	\$9,674,663.60	730,427	0.03%	96.61%	\$5.39	\$4.539
Feb-24	1,868,175,000	1,916,869,806	97.46%	\$10,069,463.25	\$8,700,672.05	268,834	0.01%	97.47%	\$5.39	\$4.539
Mar-24	1,927,795,000	1,971,770,225	97.77%	\$10,390,815.05	\$8,949,831.10	340,529	0.02%	97.79%	\$5.39	\$4.539
Apr-24	1,951,120,000	1,992,959,991	97.90%	\$10,516,636.80	\$9,046,045.40	426,636	0.02%	97.92%	\$5.39	\$4.539
May-24	2,285,252,000	2,331,031,384	98.04%	\$12,751,706.16	\$10,580,551.45	964,148	0.04%	98.08%	\$5.58	\$4.539
Jun-24	2,558,136,000	2,613,555,125	97.88%	\$14,274,398.88	\$12,265,414.20	669,121	0.03%	97.91%	\$5.58	\$4.693
Jul-24	2,577,734,000	2,637,750,416	97.72%	\$14,383,755.72	\$12,378,962.70	5,976,667	0.23%	97.95%	\$5.58	\$4.693
Aug-24	2,723,982,000	2,791,119,391	97.59%	\$15,199,819.56	\$13,098,723.30	5,570,100	0.20%	97.79%	\$5.58	\$4.693
Sep-24	2,607,811,000	2,668,243,213	97.74%	\$14,551,585.38	\$12,522,065.40	887,220	0.03%	97.77%	\$5.58	\$4.693
Oct-24	2,256,800,000	2,311,304,709	97.64%	\$12,592,944.00	\$10,846,953.00	715,430	0.03%	97.67%	\$5.58	\$4.693
Nov-24	1,872,414,000	1,918,174,238	97.61%	\$10,448,070.12	\$9,001,956.60	517,416	0.03%	97.64%	\$5.58	\$4.693
TOTALS (1)	927,393,867,798	954,020,218,123	97.21%	\$2,381,483,278.58	\$2,100,793,224.05	886,809,072	0.09%	97.30%	\$2.57	\$2.202

(1) - SINCE MAY 1, 1992

(2) - REPRESENTS DU PAGE PUMP STATION, METER TESTING AND CONSTRUCTION PROJECT USAGE

(3) - DOES NOT INCLUDE FIXED COST PAYMENTS

YTD

Nov-23	17,103,057,000	17,542,960,044	97.49%	92,185,477	79,076,220				\$5.39	\$4.508
Nov-24	16,882,129,000	17,271,178,476	97.75%	94,202,280	80,694,627				\$5.58	\$4.672
	(220,928,000)	(271,781,568)		\$2,016,803	\$1,618,407					
	-1.3%	-1.5%		2.2%	2.0%					

Month

Nov-23	1,902,725,000	1,957,768,374	97.19%	10,255,688	8,886,311				\$5.39	\$4.539
Nov-24	1,872,414,000	1,918,174,238	97.61%	10,448,070	9,001,957				\$5.58	\$4.693
	(30,311,000)	(39,594,136)		\$192,382	\$115,646					
	-1.6%	-2.0%		1.9%	1.3%					

Nov>Oct (384,386,000) (393,130,471) (2,144,874) (1,844,996)

H:\Accounting\2024-2025\Com m ission Reports\Novem ber\2024\20sales 1124.xlsx

DUPAGE WATER COMMISSION
 PWS FACILITY ID# - IL435400
 MONTHLY OPERATIONS REPORT
 DUPAGE WATER COMMISSION LABORATORY BENCH SHEET RESULTS
 NOVEMBER 2024

DATE	LEXINGTON P.S. SUPPLY				DUPAGE P.S. DISCHARGE							ANALYST INT.
	FREE Cl2 (mg/L)	TURBIDITY (ntu)	O-PO4 (mg/L)		FREE Cl2 (mg/L)	TURBIDITY (ntu)	TEMP (°F)	pH	Fluoride (mg/L)	O-PO4 (mg/L)	P.A.C. (LBS/MG)	
1	1.24	0.09	0.58		1.20	0.11	65	7.2	0.7	0.55	0	RC
2	1.29	0.09	0.62		1.29	0.10	65	7.2	0.6	0.63	0	KD
3	1.29	0.10	0.57		1.27	0.11	65	7.2	0.6	0.60	0	KD
4	1.38	0.10	0.55		1.26	0.10	65	7.2	0.6	0.58	0	RC
5	1.25	0.09	0.58		1.25	0.09	64	7.2	0.7	0.52	0	RC
6	1.37	0.09	0.64		1.25	0.09	64	7.2	0.7	0.65	0	KD
7	1.41	0.08	0.61		1.33	0.09	63	7.2	0.7	0.63	0	KD
8	1.36	0.08	0.60		1.26	0.10	63	7.2	0.7	0.62	0	KD
9	1.32	0.09	0.60		1.19	0.12	65	7.3	0.7	0.59	0	RC
10	1.34	0.10	0.58		1.18	0.11	63	7.3	0.7	0.58	0	RC
11	1.32	0.10	0.59		1.20	0.10	63	7.2	0.7	0.59	0	KD
12	1.34	0.11	0.65		1.22	0.10	62	7.3	0.7	0.62	0	KD
13	1.22	0.08	0.61		1.15	0.11	62	7.2	0.7	0.63	0	RC
14	1.36	0.10	0.58		1.26	0.11	62	7.2	0.7	0.59	0	RC
15	1.31	0.09	0.55		1.27	0.10	61	7.2	0.7	0.55	0	RC
16	1.33	0.10	0.59		1.25	0.10	61	7.3	0.7	0.57	0	AM
17	1.29	0.11	0.58		1.26	0.10	61	7.3	0.7	0.56	0	AM
18	1.32	0.09	0.58		1.25	0.09	61	7.2	0.8	0.58	0	AM
19	1.33	0.08	0.59		1.28	0.10	62	7.2	0.7	0.63	0	RC
20	1.29	0.09	0.58		1.26	0.09	61	7.2	0.7	0.61	0	AM
21	1.33	0.09	0.60		1.28	0.09	60	7.3	0.7	0.60	0	AM
22	1.30	0.09	0.59		1.24	0.10	60	7.3	0.7	0.62	0	AM
23	1.19	0.10	0.60		1.31	0.10	60	7.3	0.7	0.61	0	JS
24	1.30	0.10	0.58		1.29	0.09	60	7.2	0.7	0.60	0	JS
25	1.31	0.10	0.60		1.27	0.09	60	7.2	0.7	0.59	0	AM
26	1.36	0.09	0.57		1.29	0.10	59	7.2	0.7	0.57	0	AM
27	1.40	0.10	0.60		1.34	0.10	59	7.1	0.6	0.61	0	JS
28	1.37	0.09	0.59		1.35	0.09	59	7.2	0.7	0.60	0	JS
29	1.43	0.10	0.62		1.26	0.09	59	7.3	0.6	0.63	0	JS
30	1.34	0.10	0.60		1.24	0.10	58	7.2	0.7	0.61	0	AM
31												
AVG.	1.32	0.09	0.59		1.26	0.10	62	7.2	0.7	0.60	0	
MAX.	1.43	0.11	0.65		1.35	0.12	65	7.3	0.8	0.65	0	
MIN.	1.19	0.08	0.55		1.15	0.09	58	7.1	0.6	0.52	0	

 Date 12/4/24
 Mike Weed, Operations Supervisor
 Illinois ROINC # 186860234

DU PAGE WATER COMMISSION SALES FY 2024-25, 2023-24 & 2022-23 VS. HISTORICAL AVERAGE

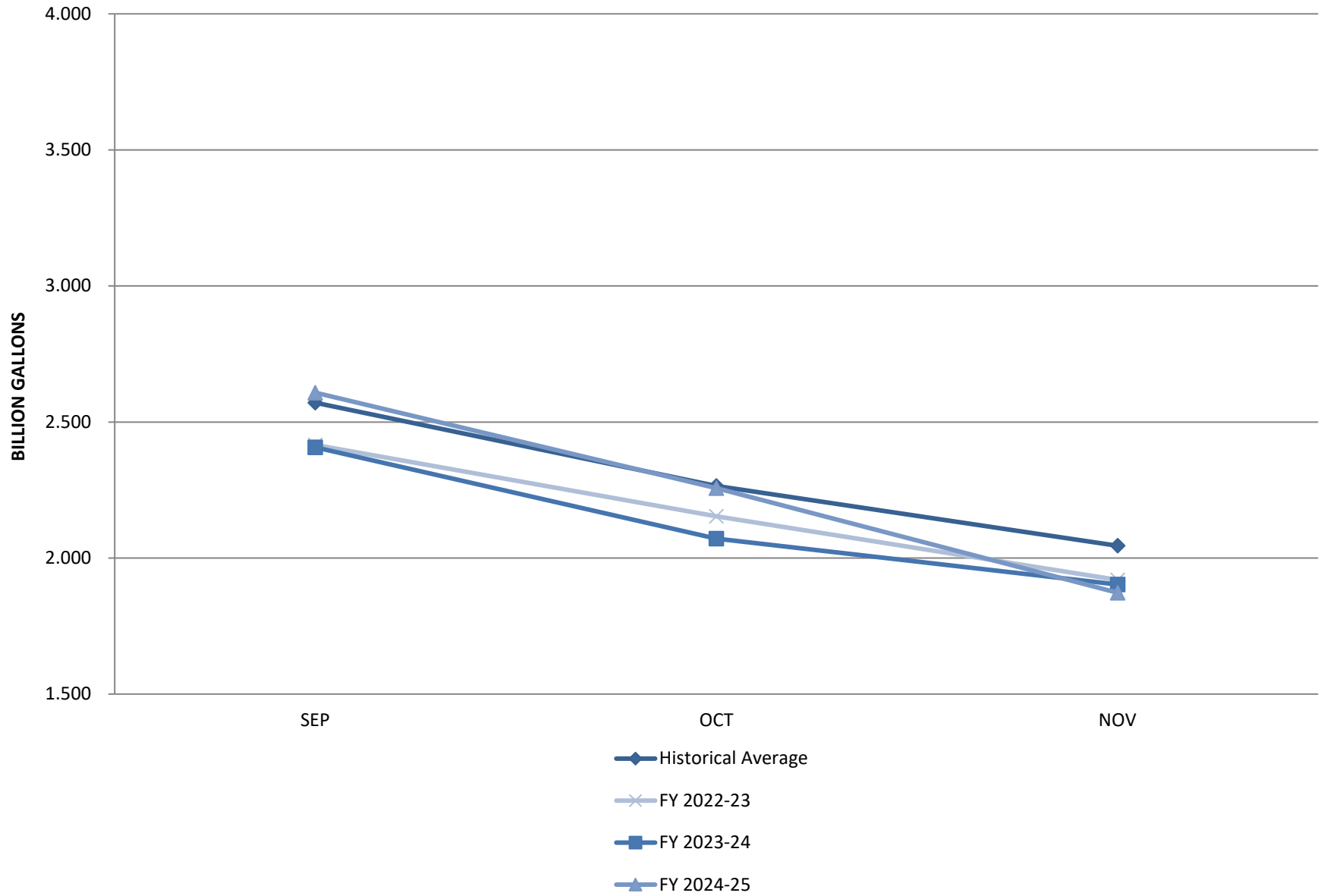

DU PAGE WATER COMMISSION SALES FY 2024-25 VS. ALLOCATION

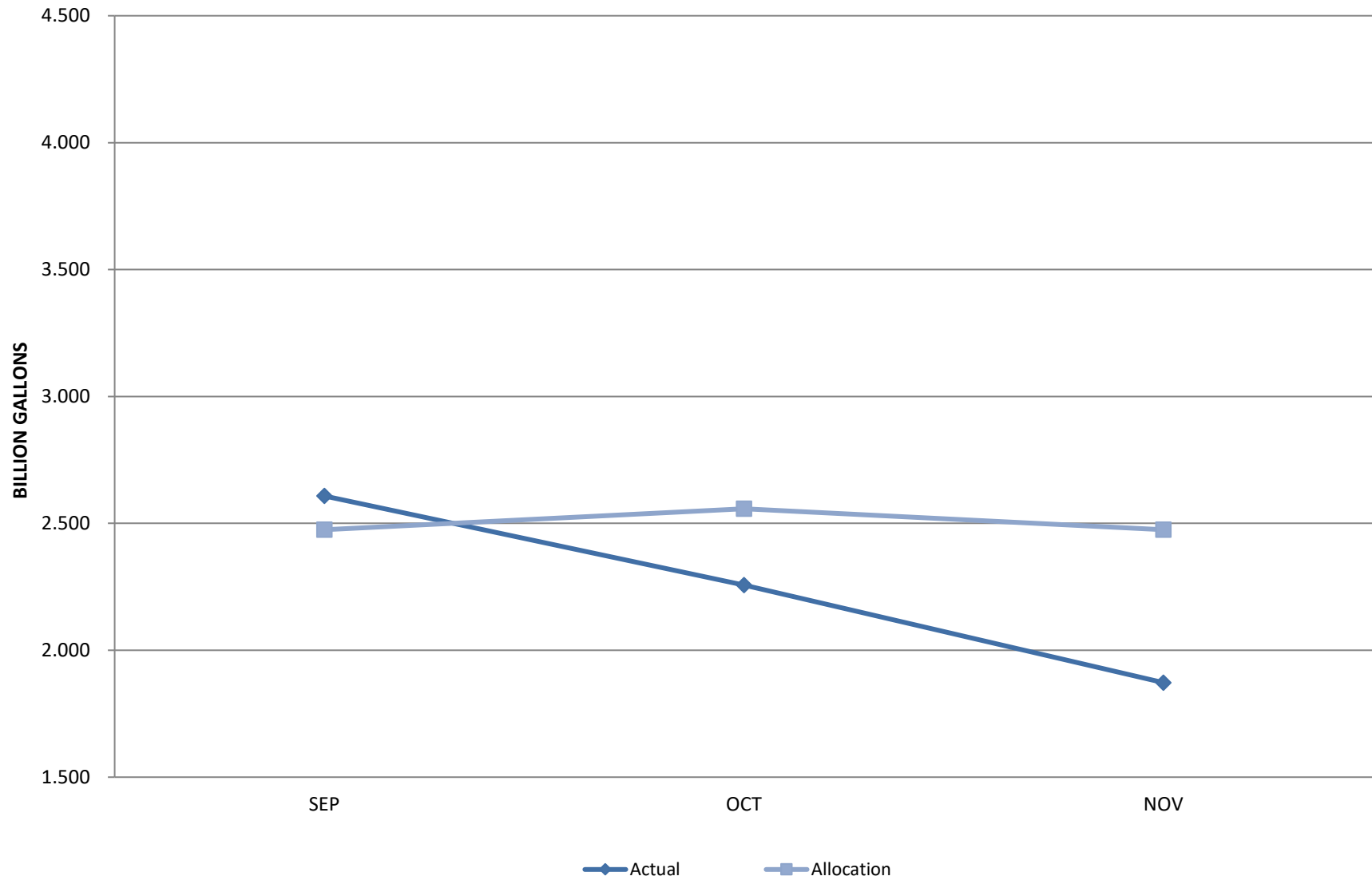



MEMORANDUM

To: Paul May – General Manager

From: Chris Bostick – Manager of Water Operations
Jeff Loster – Manager of Engineering

Mike Weed – Operations & Instrumentation Supervisor
Dariusz Panaszek – Pipeline & Remote Facilities Supervisor
Denis Cuvalo – Systems Engineer and Information Technology Supervisor

Date: 1/9/2025

Subject: Status of Operations, Engineering and Construction

Operations Overview

The Commission's sales for December 2024 were a total of 2.00 billion gallons. This represents an average daily demand of 64.6 million gallons per day (MGD), which is lower than the December 2023 average day demand of 66.6 MGD. The maximum day demand was 70.3 MGD recorded on December 14, 2024, which is lower than the December 2023 maximum day demand of 71.2 MGD. The minimum day flow was 59.7 MGD.

The recorded total precipitation for December 2024 was 1.59 inches compared to 2.89 inches for December 2023. The level of Lake Michigan for December 2024 is 578.18 (Feet International Great Lakes Datum (IGLD) 1985) compared to 578.61 (Feet IGLD 1985) for December 2023.

DuPage Operations & Instrumentation Maintenance and Construction Overview

The 2024 Meter Testing Program is 100% complete.

The Reservoir Influent and Effluent Surge Relief Valves were rebuilt in December.

High Lift Pump No. 3 motor is experiencing start-up issues. Service is forthcoming.

High Lift Pump Isolation Valve replacement project is tentatively scheduled to start the week of February 3.

Resolution R-6-25 appears on the agenda seeking authorization for the General Manager to purchase material and services from a sole source provider to maintain electric motors for High-Lift Pumping equipment on an as-needed basis at a cost not-to-exceed \$100,000 for Fiscal Year 25/26.

City of Chicago Water Treatment Modifications

The City of Chicago's transition from their current blended phosphate to phosphoric acid is reportedly ongoing to optimize the control of lead and copper release through household plumbing. Staff continue to share updated information with all DWC Customers as it is received from the City.

DWC staff continues monitoring certain water quality parameters to follow the progress during the City's transition of the treatment technique. The expanded monitoring program will continue through late spring 2025.

Lexington Operations and Maintenance Overview

No Change: Investigations continue, and additional proposals are being sought for the installation of vibration analysis instrumentation; proposals will be brought forth for Board consideration in the future.

No Change: Commission staff have informed Chicago DWM staff that the Lexington SCADA node is once again in failure mode. Chicago DWM reports that they will continue to troubleshoot their SCADA system deficiencies to identify the root cause of the ongoing issues.

Alternate Water Source

Staff will be engaging with the Village of Northbrook regarding tree removal permitting and contractors to perform tree removal and site cleanup of fly-dumped materials. The work will be performed once the ground has frozen and become more stable.

Pipeline & Remote Facilities Maintenance Overview

Pipeline and Remote Facilities staff continue to inspect Remote Facilities and perform preventative maintenance and corrective work as needed.

Pipeline staff are performing an annual valve exercising program.

Pipeline staff and DeLasCasas CP, LLC are performing testing and maintenance on the galvanic cathodic protection systems on selected feeder mains and meter station piping.

Resolution R-09-25 appears on the agenda to approve Work Authorization Order No. 030 to Quick Response Contractor, Rossi Contractors, Inc. The work is necessary due to the deteriorating conditions of various types of vault structures and surrounding pavement found during routine inspections by staff.

Resolution R-10-25 appears on the agenda to approve Work Authorization Order No. 029 to Quick Response Contractor, Rossi Contractors, Inc. The modification work is in preparation for the feasibility study to provide adequate cathodic protection according to the Association for Materials Protection and Performance (AMPP) standards.

Resolution R-12-25 appears on the agenda to authorize the General Manager to purchase custom manhole frames and lids to Commission standard from a sole source manufacturer.

SCADA & Information Technology Overview

The SCADA Replacement Project (Contract PSD-9/21) is ongoing. The DWC campus control panel replacement has been completed with final site acceptance testing and open items work being

completed. The Factory Acceptance Test (FAT) for the remote site control panels including Lexington, Tank Sites, Meters Stations, and ROV's is nearing completion. Action items from the FAT as well as additional testing and preparation is taking place throughout the month of January. Following the completion of these items, Commission and Concentric staff will begin replacing RTU panels at the remote sites. The inspection and maintenance of all remote site antenna systems is underway and roughly 80% complete. Replacement of the fiber network for the DWC campus is anticipated to begin this Spring following the completion of all control and network upgrades with the addition of a new duct bank to complete a ring topology for the new fiber network. The Access Control security system upgrade has been completed and staff is currently working on addressing any open items from the upgrade.

Resolution R-04-25 appears on the agenda to approve the purchase and installation of additional security cameras through our authorized security vendor, Schneider Electric. The addition of the ten security cameras is to address areas that require camera coverage in various locations around the DWC campus.

Engineering & Capital Improvement Program Overview

The Commission's annual Cathodic Protection Project on the TW-2 pipeline has wrapped up for the year. All open sites have been closed up for the winter and restored. Additional permitting efforts will take place over the winter months so that remaining efforts can be completed in spring.

Design of a Joint Facility (Metering Station and Pressure Adjusting Station) at Lombard's fifth connection point remains ongoing. Design will be completed in 2025 with construction to follow.

WaterLink Communities (Montgomery/Oswego/Yorkville)

The Phase II engineering effort remains ongoing and is approximately 61% complete. Preliminary field work (utility potholing, soil borings, etc.) is nearly complete, with remaining work in the ComEd corridor underway and expected to finish in January.

Development of 90% plans has recently been completed, with all documents having been submitted to Commission Staff for review. During the month of January, the 90% documents are also scheduled to be submitted to the 28 agencies having some form of permitting jurisdiction on the project. The permitting phase is generally expected to last approximately 60-90 days for most agencies, with longer durations anticipated for ComEd and IDOT. Coordination with these permitting agencies and the WaterLink Communities remains ongoing to make sure any design changes are quickly and accurately represented to all impacted parties.

The acclimation phase of the corrosion control treatment study, performed by the Cornwell Engineering Group, is nearing completion with associated reports having been submitted to the Illinois Environmental Protection Agency (IEPA) for review/comment in December. Late January will see the study transition from analysis of the current water supplies to water from the Jardine Water Purification Plant. This study is required by the IEPA and is expected to be completed by November 2025.

Additional efforts related to property (easement) acquisition are also underway, with real estate appraisals to begin in earnest during the month of January. Items related to easement acquisition will likely be brought forward for Board consideration over the next several months.

As the WaterLink Project continues to proceed toward the construction phase, Staff is recommending approval of R-11-25, which is a contract with Burns & McDonnell to serve as the construction engineer on the “Book Road” bid package and includes additional items to begin identifying tasks/efforts related to the Program Manager role. It is anticipated that Burns & McDonnell will serve as the Program Manager throughout the construction phase (on all bid packages) with additional contract proposals by other firms brought forward for consideration to provide construction engineering services on the remaining bid packages.

Also related to WaterLink construction phase, R-13-25 appears on the agenda which seeks authority to pre-purchase three, 48” butterfly valves associated with the WaterLink connection to the existing DWC supply network. These valves are critical in ensuring a proper connection and provide redundancy if a future shutdown of the existing DWC supply network were needed to the east or west of the proposed WaterLink connection. Unfortunately, the connection work is limited to the low-flow months of late fall/winter. With substantial lead times associated with valves of this magnitude, Staff feels that it is best to pre-purchase these three valves so that they are already on-hand at the time when the connection can be made.

Board Action Items

Resolution R-04-25: A Resolution Approving the Purchase and Installation of Additional Security Cameras (**Schneider Electric – \$128,308**)

Resolution R-06-25: A Resolution Authorizing the General Manager to Purchase Material and Labor Services for the High-Lift Pump Motors including Ancillary Equipment (**WEG Electric – Not-To-Exceed \$100,000**)

Resolution R-07-25: A Resolution Authorizing Classen, White and Associates to Perform Surveying Services in Relation to the Commission’s Hydraulic Model (**Estimated Cost of \$34,019**)

Resolution R-09-25: A Resolution Approving and Ratifying Certain Work Authorization Orders Under Quick Response Contract QR-12/21 (**WAO No. 030 – Rossi Contractors, Inc – Estimated Expense of \$123,200**)

Resolution R-10-25: A Resolution Approving and Ratifying Certain Work Authorization Orders Under Quick Response Contract QR-12/21 (**WAO No. 029 – Rossi Contractors, Inc. – Not-to-Exceed \$91,920**)

Resolution R-11-25: A Resolution Approving Scope of Services for Task Order No. 5 under a Maser Contract with Burns & McDonnell Engineering Co., Inc. (**Not-To-Exceed \$3,613,698.**)

Resolution R-12-25: A Resolution Authorizing the General Manager to Purchase Frames and Lids from a Sole Source Manufacturer (**Neenah Foundry – Cost Not-to-Exceed \$48,867.00**)

Resolution R-13-25: A Resolution Authorizing the General Manager to Pre-Purchase Three, 48” Butterfly Valves (**Val-Matic Valve and Manufacturing Corp. – Cost Not-to-Exceed \$176,126.00**)

Attachments

1. DuPage Laboratory Bench Sheets for December 2024
2. Water Sales Analysis 01-May-2020 to 31-December-2024
3. DuPage Water Commission Chart Sales vs. Historical Average
4. DuPage Water Commission Chart Sales vs. Allocation
5. WaterLink Status Report

DU PAGE WATER COMMISSION
WATER SALES ANALYSIS

01-May-92 TO 31-Dec-24

PER DAY AVERAGE 77,884,597

MONTH	SALES TO CUSTOMERS (GALLONS)	PURCHASES FROM CHICAGO (GALLONS)	GALLONS BILLED %	BILLINGS TO CUSTOMERS	BILLINGS FROM CHICAGO	DOCUMENTED WATER USE (2)	DOCUMENTED COMMISSION WATER USE %	TOTAL ACCOUNTED FOR %	DWC OPER. & MAINT. RATE (3)	CHGO RATE
May-20	2,084,924,000	2,141,838,951	97.34%	\$10,362,072.28	\$8,513,809.83	376,100	0.02%	97.36%	\$4.97	\$3.975
Jun-20	2,522,634,000	2,596,146,493	97.17%	\$12,537,490.98	\$10,571,508.52	731,078	0.03%	97.20%	\$4.97	\$4.072
Jul-20	2,782,507,000	2,872,440,835	96.87%	\$13,829,059.79	\$11,696,579.08	647,000	0.02%	96.89%	\$4.97	\$4.072
Aug-20	3,078,522,000	3,180,137,701	96.80%	\$15,300,254.34	\$12,949,520.72	3,694,350	0.12%	96.92%	\$4.97	\$4.072
Sep-20	2,427,570,000	2,510,646,051	96.69%	\$12,065,022.90	\$10,223,350.72	1,148,848	0.05%	96.74%	\$4.97	\$4.072
Oct-20	2,143,671,000	2,203,255,879	97.30%	\$10,654,044.87	\$8,971,657.94	748,000	0.03%	97.33%	\$4.97	\$4.072
Nov-20	1,897,985,000	1,957,960,123	96.94%	\$9,432,985.45	\$7,972,813.62	200,026	0.01%	96.95%	\$4.97	\$4.072
Dec-20	1,955,711,000	2,027,160,874	96.48%	\$9,719,883.67	\$8,254,599.08	348,955	0.02%	96.49%	\$4.97	\$4.072
Jan-21	1,988,344,000	2,040,857,402	97.43%	\$9,882,069.68	\$8,310,371.34	205,828	0.01%	97.44%	\$4.97	\$4.072
Feb-21	1,915,366,000	1,971,858,620	97.14%	\$9,519,369.02	\$8,029,408.30	290,224	0.01%	97.15%	\$4.97	\$4.072
Mar-21	1,986,888,000	2,055,661,022	96.65%	\$9,874,833.36	\$8,370,651.68	512,237	0.02%	96.68%	\$4.97	\$4.072
Apr-21	1,959,759,000	2,010,756,459	97.46%	\$9,740,002.23	\$8,187,800.30	1,013,926	0.05%	97.51%	\$4.97	\$4.072
May-21	2,331,364,000	2,401,447,849	97.08%	\$11,586,879.08	\$9,778,695.64	1,625,835	0.07%	97.15%	\$4.97	\$4.072
Jun-21	2,646,312,000	2,727,518,236	97.02%	\$13,152,170.64	\$11,226,465.06	872,815	0.03%	97.05%	\$4.97	\$4.116
Jul-21	2,661,520,000	2,750,318,994	96.77%	\$13,227,754.40	\$11,320,312.98	772,815	0.03%	96.80%	\$4.97	\$4.116
Aug-21	2,736,795,000	2,818,422,046	97.10%	\$13,601,871.15	\$11,600,625.14	458,555	0.02%	97.12%	\$4.97	\$4.116
Sep-21	2,616,212,000	2,698,022,374	96.97%	\$13,002,573.64	\$11,105,060.09	1,237,080	0.05%	97.01%	\$4.97	\$4.116
Oct-21	2,128,141,000	2,179,013,387	97.67%	\$10,576,860.77	\$8,968,819.10	396,147	0.02%	97.68%	\$4.97	\$4.116
Nov-21	1,896,311,000	1,961,815,221	96.66%	\$9,424,665.67	\$8,074,831.45	462,613	0.02%	96.68%	\$4.97	\$4.116
Dec-21	1,950,793,000	2,010,917,641	97.01%	\$9,695,441.21	\$8,276,937.01	382,031	0.02%	97.03%	\$4.97	\$4.116
Jan-22	2,046,043,000	2,110,214,643	96.96%	\$10,168,833.71	\$8,685,674.26	621,078	0.03%	96.99%	\$4.97	\$4.116
Feb-22	1,879,376,000	1,935,513,559	97.10%	\$9,340,498.72	\$7,966,573.81	247,750	0.01%	97.11%	\$4.97	\$4.116
Mar-22	1,990,472,000	2,061,912,643	96.54%	\$9,892,645.84	\$8,486,832.44	459,838	0.02%	96.56%	\$4.97	\$4.116
Apr-22	1,935,992,000	1,981,414,298	97.71%	\$9,621,880.24	\$8,155,501.25	285,652	0.01%	97.72%	\$4.97	\$4.116
May-22	2,276,513,000	2,344,221,635	97.11%	\$11,792,337.34	\$9,648,816.25	5,698,667	0.24%	97.35%	\$5.18	\$4.116
Jun-22	2,682,480,000	2,772,533,130	96.75%	\$13,895,246.40	\$11,982,888.19	690,925	0.02%	96.78%	\$5.18	\$4.322
Jul-22	2,804,661,000	2,892,532,635	96.96%	\$14,528,143.98	\$12,501,526.05	883,858	0.03%	96.99%	\$5.18	\$4.322
Aug-22	2,688,224,000	2,772,533,130	96.96%	\$13,925,000.32	\$11,982,888.19	906,806	0.03%	96.99%	\$5.18	\$4.322
Sep-22	2,415,535,000	2,474,643,822	97.61%	\$12,512,471.30	\$10,695,410.60	1,021,063	0.04%	97.65%	\$5.18	\$4.322
Oct-22	2,153,410,000	2,220,050,683	97.00%	\$11,154,663.80	\$9,595,059.05	2,891,786	0.13%	97.13%	\$5.18	\$4.322
Nov-22	1,919,552,000	1,979,550,491	96.97%	\$9,943,279.36	\$8,555,617.22	1,008,092	0.05%	97.02%	\$5.18	\$4.322
Dec-22	2,071,113,000	2,123,449,660	97.54%	\$10,728,365.34	\$9,177,549.43	552,389	0.03%	97.56%	\$5.18	\$4.322
Jan-23	2,014,750,000	2,060,255,805	97.79%	\$10,436,405.00	\$8,904,425.59	337,423	0.02%	97.81%	\$5.18	\$4.322
Feb-23	1,835,597,000	1,883,158,917	97.47%	\$9,508,392.46	\$8,139,012.84	529,206	0.03%	97.50%	\$5.18	\$4.322
Mar-23	1,971,974,000	2,026,257,691	97.32%	\$10,214,825.32	\$8,757,453.41	306,690	0.02%	97.34%	\$5.18	\$4.322
Apr-23	1,962,197,000	2,010,451,747	97.60%	\$10,164,180.46	\$8,689,172.45	349,596	0.02%	97.62%	\$5.18	\$4.322
May-23	2,474,377,000	2,540,440,833	97.40%	\$13,336,892.03	\$10,979,785.28	684,441	0.03%	97.43%	\$5.39	\$4.322
Jun-23	2,971,436,000	3,043,540,086	97.63%	\$16,016,040.04	\$13,814,628.45	678,930	0.02%	97.65%	\$5.39	\$4.539
Jul-23	2,567,425,000	2,639,887,376	97.26%	\$13,838,420.75	\$11,982,448.80	1,047,600	0.04%	97.29%	\$5.39	\$4.539
Aug-23	2,708,945,000	2,773,069,509	97.69%	\$14,601,213.55	\$12,586,962.50	832,992	0.03%	97.72%	\$5.39	\$4.539
Sep-23	2,406,858,000	2,471,708,096	97.38%	\$12,972,964.62	\$11,219,083.05	753,904	0.03%	97.41%	\$5.39	\$4.539
Oct-23	2,071,291,000	2,116,545,770	97.86%	\$11,164,258.49	\$9,607,001.25	1,034,131	0.05%	97.91%	\$5.39	\$4.539
Nov-23	1,902,725,000	1,957,768,374	97.19%	\$10,255,687.75	\$8,886,310.65	809,342	0.04%	97.23%	\$5.39	\$4.539
Dec-23	1,972,754,000	2,031,158,416	97.12%	\$10,633,144.06	\$9,219,428.05	2,329,064	0.11%	97.24%	\$5.39	\$4.539
Jan-24	2,058,390,000	2,131,445,175	96.57%	\$11,094,722.10	\$9,674,663.60	730,427	0.03%	96.61%	\$5.39	\$4.539
Feb-24	1,868,175,000	1,916,869,806	97.46%	\$10,069,463.25	\$8,700,672.05	268,834	0.01%	97.47%	\$5.39	\$4.539
Mar-24	1,927,795,000	1,971,770,225	97.77%	\$10,390,815.05	\$8,949,831.10	340,529	0.02%	97.79%	\$5.39	\$4.539
Apr-24	1,951,120,000	1,992,959,991	97.90%	\$10,516,636.80	\$9,046,045.40	426,636	0.02%	97.92%	\$5.39	\$4.539
May-24	2,285,252,000	2,331,031,384	98.04%	\$12,751,706.16	\$10,580,551.45	964,148	0.04%	98.08%	\$5.58	\$4.539
Jun-24	2,558,136,000	2,613,555,125	97.88%	\$14,274,398.88	\$12,265,414.20	669,121	0.03%	97.91%	\$5.58	\$4.693
Jul-24	2,577,734,000	2,637,750,416	97.72%	\$14,383,755.72	\$12,378,962.70	5,976,667	0.23%	97.95%	\$5.58	\$4.693
Aug-24	2,723,982,000	2,791,119,391	97.59%	\$15,199,819.56	\$13,098,723.30	5,570,100	0.20%	97.79%	\$5.58	\$4.693
Sep-24	2,607,811,000	2,668,243,213	97.74%	\$14,551,585.38	\$12,522,065.40	887,220	0.03%	97.77%	\$5.58	\$4.693
Oct-24	2,256,800,000	2,311,304,709	97.64%	\$12,592,944.00	\$10,846,953.00	715,430	0.03%	97.67%	\$5.58	\$4.693
Nov-24	1,872,414,000	1,918,174,238	97.61%	\$10,448,070.12	\$9,001,956.60	517,416	0.03%	97.64%	\$5.58	\$4.693
Dec-24	2,003,025,000	2,053,944,598	97.52%	\$11,176,879.50	\$9,639,162.00	465,013	0.02%	97.54%	\$5.58	\$4.693
TOTALS (1)	929,396,892,798	956,074,162,721	97.21%	\$2,392,660,158.08	\$2,110,432,386.05	887,274,085	0.09%	97.30%	\$2.57	\$2.207

- (1) - SINCE MAY 1, 1992
- (2) - REPRESENTS DU PAGE PUMP STATION, METER TESTING AND CONSTRUCTION PROJECT USAGE
- (3) - DOES NOT INCLUDE FIXED COST PAYMENTS

YTD

Dec-23	19,075,811,000	19,574,118,460	97.45%	102,818,621	88,295,648			\$5.39	\$4.511
Dec-24	18,885,154,000	19,325,123,074	97.72%	105,379,159	90,333,789			\$5.58	\$4.674
	(190,657,000)	(248,995,386)		\$2,560,538	\$2,038,141				
	-1.0%	-1.3%		2.5%	2.3%				
Month									
Dec-23	1,972,754,000	2,031,158,416	97.12%	10,633,144	9,219,428			\$5.39	\$4.539
Dec-24	2,003,025,000	2,053,944,598	97.52%	11,176,880	9,639,162			\$5.58	\$4.693
	30,271,000	22,786,182		\$543,735	\$419,734				
	1.5%	1.1%		5.1%	4.6%				
Dec>Nov	130,611,000	135,770,360		728,899	637,205				

DUPAGE WATER COMMISSION
PWS FACILITY ID# - IL435400
MONTHLY OPERATIONS REPORT
DUPAGE WATER COMMISSION LABORATORY BENCH SHEET RESULTS
DECEMBER 2024

DATE	LEXINGTON P. S. SUPPLY			DUPAGE P. S. DISCHARGE								ANALYST INT.
	FREE Cl2 (mg/L)	TURBIDITY (ntu)	O-PO4 (mg/L)	FREE Cl2 (mg/L)	TURBIDITY (ntu)	TEMP (°F)	pH	Fluoride (mg/L)	O-PO4 (mg/L)	P.A.C. (LBS/MG)		
1	1.29	0.09	0.60	1.23	0.10	58	7.2	0.7	0.59	0	AM	
2	1.36	0.09	0.60	1.29	0.10	57	7.2	0.7	0.59	0	AM	
3	1.42	0.09	0.62	1.38	0.10	57	7.1	0.6	0.60	0	JS	
4	1.39	0.09	0.61	1.37	0.09	56	7.2	0.8	0.61	0	AM	
5	1.37	0.10	0.62	1.33	0.10	56	7.2	0.8	0.60	0	AM	
6	1.35	0.10	0.63	1.38	0.10	54	7.1	0.8	0.60	0	AM	
7	1.43	0.07	0.67	1.42	0.08	53	7.2	0.8	0.62	0	JS	
8	1.54	0.08	0.67	1.44	0.09	53	7.2	0.7	0.63	0	JS	
9	1.41	0.09	0.62	1.40	0.10	52	7.2	0.7	0.59	0	AM	
10	1.44	0.09	0.59	1.38	0.09	51	7.2	0.8	0.57	0	AM	
11	1.25	0.10	0.62	1.35	0.08	49	7.3	0.8	0.60	0	JS	
12	1.35	0.09	0.63	1.23	0.09	49	7.2	0.7	0.62	0	JS	
13	1.43	0.09	0.60	1.38	0.09	49	7.2	0.8	0.60	0	JS	
** 14	1.42	0.04		1.40	0.05	42	7.2			0	SCADA	
** 15	1.37	0.05		1.34	0.05	41	7.3			0	SCADA	
16	1.39	0.10	0.64	1.21	0.08	52	7.3	0.7	0.62	0	JS	
17	1.32	0.09	0.63	1.37	0.09	54	7.1	0.8	0.59	0	JS	
18	1.35	0.08	1.07	1.28	0.10	50	7.2	0.8	0.99	0	KD	
19	1.30	0.10	0.96	1.29	0.12	51	7.2	0.8	1.02	0	KD	
20	1.36	0.12	0.95	1.25	0.11	51	7.2	0.8	0.98	0	KD	
21	1.45	0.10	0.92	1.25	0.12	55	7.3	0.7	0.93	0	RC	
22	1.35	0.10	0.98	1.25	0.14	57	7.3	0.7	0.90	0	RC	
23	1.36	0.10	0.95	1.21	0.13	53	7.3	0.7	0.94	0	KD	
24	1.39	0.13	0.93	1.29	0.15	52	7.3	0.8	0.99	0	KD	
25	1.41	0.09	0.96	1.22	0.12	53	7.3	0.7	0.93	0	RC	
26	1.34	0.08	0.98	1.18	0.13	53	7.3	0.7	0.93	0	RC	
27	1.45	0.08	0.96	1.30	0.11	53	7.3	0.7	0.92	0	RC	
28	1.39	0.09	0.95	1.36	0.10	53	7.2	0.8	0.99	0	RC	
29	1.40	0.08	0.94	1.27	0.10	53	7.2	0.7	0.78	0	RC	
30	1.32	0.09	0.94	1.36	0.12	52	7.3	0.7	0.93	0	RC	
31	1.41	0.09	0.96	1.26	0.10	52	7.2	0.7	0.87	0	RC	
AVG.	1.38	0.09	0.79	1.31	0.10	52	7.2	0.7	0.76	0		
MAX.	1.54	0.13	1.07	1.44	0.15	58	7.3	0.8	1.02	0		
MIN.	1.25	0.04	0.59	1.18	0.05	41	7.1	0.6	0.57	0		

Mike Weed 1/6/25
Mike Weed, Operations Supervisor
Illinois ROINC # 186860234
Date

NOTE: ** indicates readings were taken from on-line instrumentation via SCADA

DU PAGE WATER COMMISSION SALES FY 2024-25, 2023-24 & 2022-23 VS. HISTORICAL AVERAGE

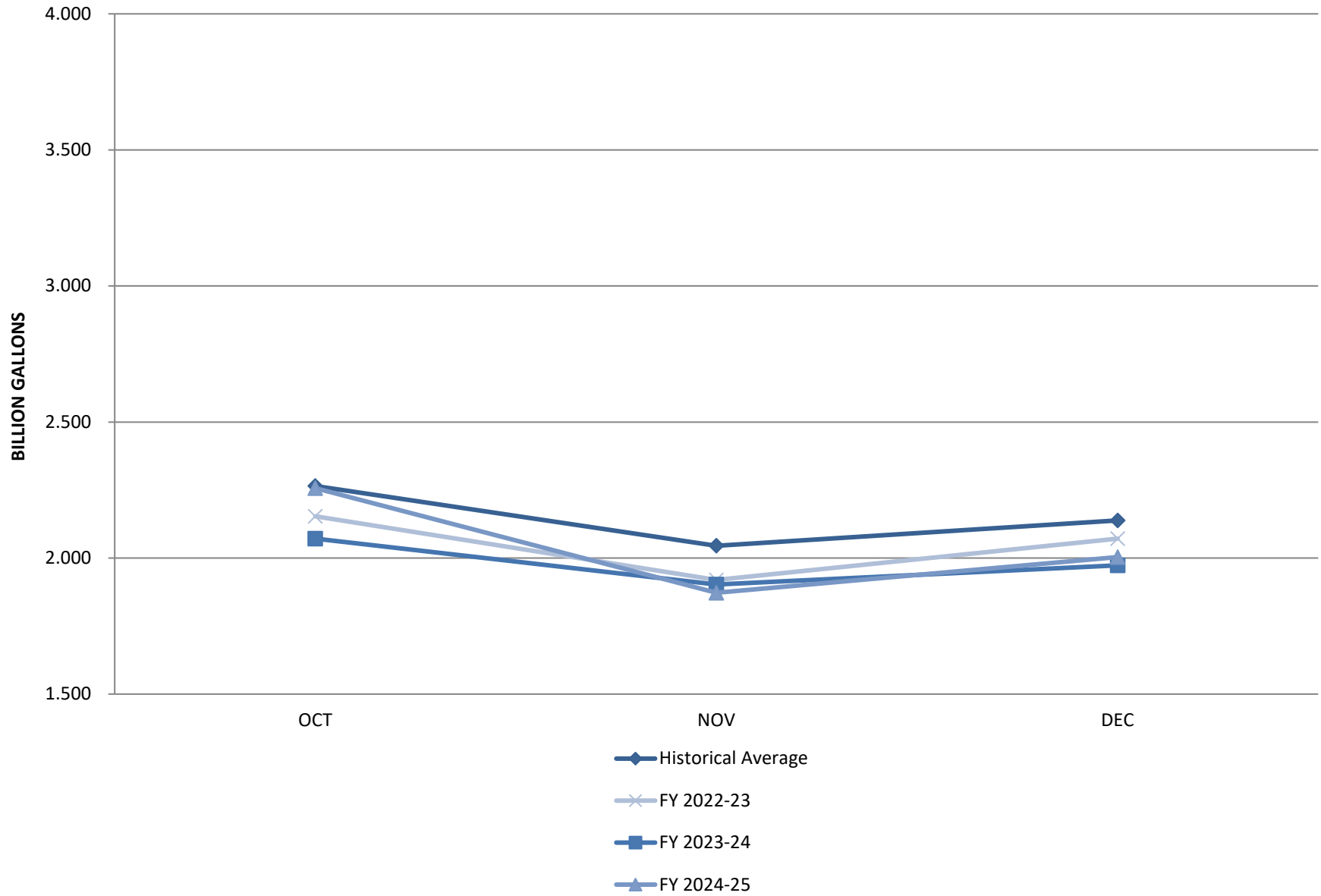

DU PAGE WATER COMMISSION SALES FY 2024-25 VS. ALLOCATION

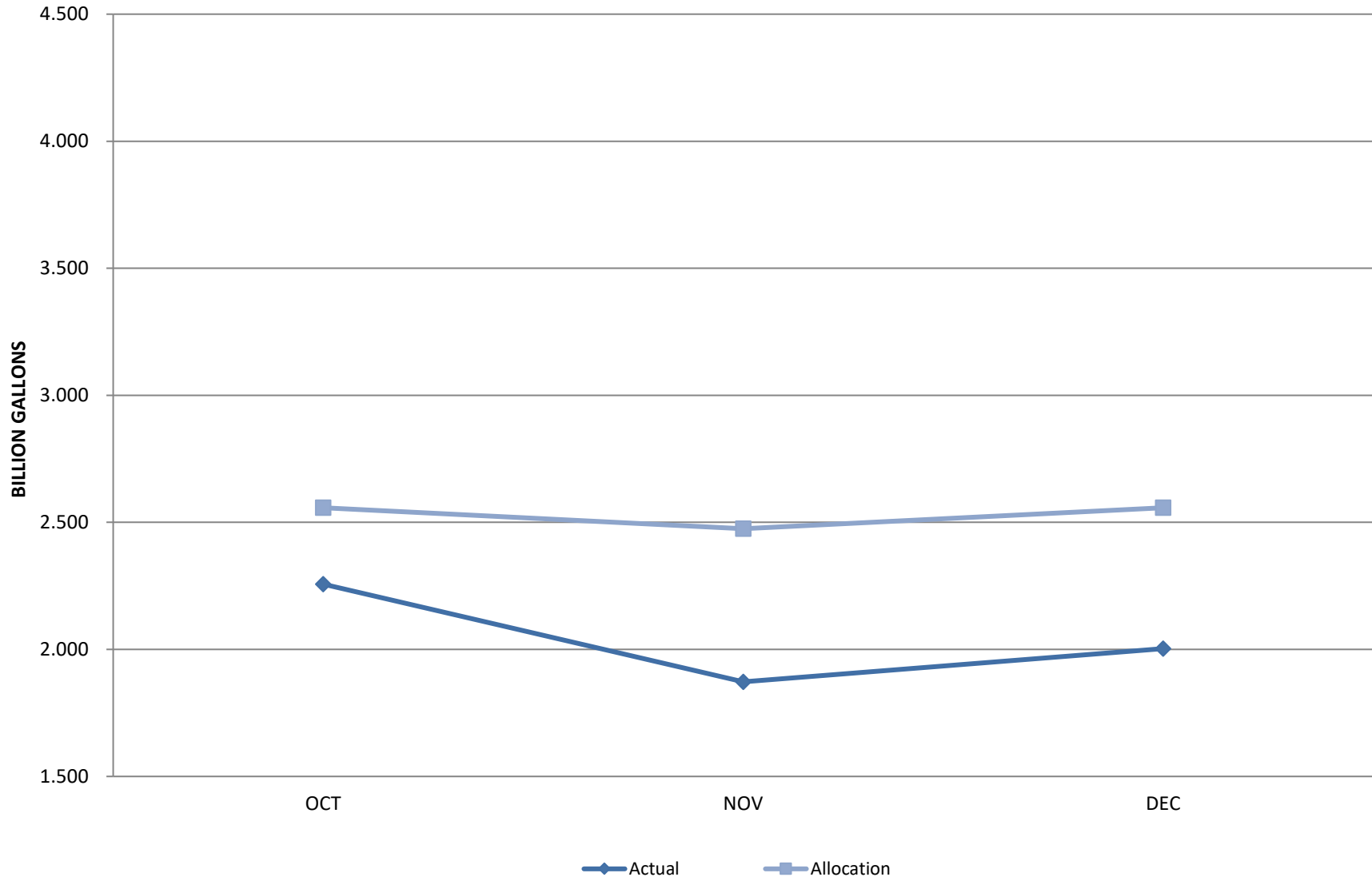



MONTHLY STATUS REPORT

LAN PROJECT #: 128-10031-001

PROJECT: DuPage Water Commission WaterLink Extension Phase II

REPORT DATE: December 11, 2024

MEETING DATE: December 19, 2024

I. Progress through December 9, 2024

A. Field data collection and surveying.

1. Final cadastral surveying work complete.
 - a) All 13 additional sections authorized in Phase 1 complete. Site surveying for 3 of the 7 delivery sites has been completed, with remainder coming from WaterLink municipal engineers.
 - b) Site topo at Oswego East HS began Aug 6 and is complete. High school engineer provided existing utility map at site.
 - c) Existing structure rim/invert data collection 100% complete. Total of approximately 1,050 structures located with rim/inverts surveyed.
2. Processing of collected Aerial LIDAR data is complete.
 - a) 100% of original scope complete. Overall width of data processing increased to facilitate design drawing set-up and minimize future re-work. Increased width processing complete.
 - b) SAM delivered additional processed data along Wolf's Crossing Rd and Douglas Rd for modified FW1 Segment 1 & 2 route to REL on August 26th.
 - c) Due to ComEd alignment changes west of Ogden Falls Blvd., additional topo processing was completed by SAM LLC. Processed data was received last week.
3. Subsurface Utility Locates
 - a) All SUE field activities completed except a few locations within ComEd ROW and Wolf's Crossing. This work is underway, with completion anticipated by Dec 20th.
4. Utility Potholing Locates
 - a) Over 400 potholes completed to date and are about 95% complete. Potholing along ComEd ROW is underway and should be completed by Dec 20th, weather permitting.



Planning
Engineering
Program Management





MONTHLY STATUS REPORT

5. Geotechnical

- a) Total of 115 borings (56%) completed to date in Phase 2.
- b) Permits from ComEd received, IDOT application on IL-71 in progress. Primary drilling crews were mobilized week of Dec 9 for borings along ComEd. Multiple crews will assist on Saturdays until project is complete. Book Road draft geotechnical report submitted to Design Team for review. Specialty rock testing underway for several locations.

6. Cathodic Protection

- a) Soil resistivity testing along project routes underway for cathodic protection design.

B. Data Collection (as-builts, GIS, design drawings).

1. WaterLink Delivery Point proposed site layouts.
2. Additional title commitments have been ordered along US Route 30, Wolf's Crossing, Douglas Rd.
3. Design team has set initial priority parcels to move to the plat preparation stage.

C. Ongoing Coordination with ComEd.

1. Approval for geotechnical and potholing work within ComEd property received on 11/5.
2. Approval/No exception email on revised alignment received on 11/5.
3. Subsequent ComEd design reviews and coordination will be performed during Phase II design as part of legal and appraisal process.

D. Land Acquisition

1. 175 of 228 Titles Received
2. 186 total parcels for easement preparation
3. Easement legal descriptions & exhibits
 - a) 40 total prepared to date

4. Appraisals to begin in earnest after holidays

E. Contract TW-6 Section 1 (Book Rd) in progress.

1. Water transmission main plan and profile design ongoing.
2. Proposed connection design at Book Road & 75th Street.
3. Remote operated valves to be placed along existing 48-inch transmission main.
4. Roadway plans and traffic control plans have been prepared.
5. In-field route review for valve locations completed to confirm actual conditions.



Planning
Engineering
Program Management





MONTHLY STATUS REPORT

F. Contract TW-6 Section 2 & 3 in progress.

1. Water transmission main plan and profile design ongoing.
2. Drawing production underway for both Sections after receiving preliminary approval from ComEd Transmission Engineering group.
3. Alignment revision into Aurora 95th Street ROW is under consideration. 90% design will remain in ComEd ROW pending further coordination with Aurora.
4. Realignment on 248th Avenue to accommodate two-way traffic during construction is underway.
5. In-field route review for valve locations completed to confirm actual conditions.
6. Tunnel locations under review based on DWC comments.
7. Drawings will be submitted to ComEd to initiate legal and real estate appraisal process.

G. Contract FW-1 Section 1 & 2 in progress.

1. Water transmission main plan and profile design ongoing.

H. Contract FW-1 Section 3 in progress.

1. Water transmission main plan and profile design ongoing.
2. Ongoing coordination with IDOT District 3 on IL Route 71 project overlap.
3. Permit application to IDOT District 3 will request several variances with regards to pipe alignment proximity to ROW line and drainage ditches.

I. Contract FW-1 Section 4 in progress.

1. Water transmission main plan and profile design ongoing.
 - a) Orchard Road, Tuscan Trail, Galena Road, IL Route 30.
 - b) ComEd design from Yorkville #2 to Orchard Road to be included in 90% Submittal.

J. Contract MS-22 Meter Stations in progress.

1. Meter station piping and building layouts ongoing.
2. WaterLink feedback received on architectural treatments and site layout modifications.
3. Architectural and structural design for the buildings is ongoing.
 - a) 75% design submitted on 10/31/24.
 - b) Comments received from DWC and WaterLink communities for 90% submittal preparation.



Planning
Engineering
Program Management





MONTHLY STATUS REPORT

II. Scope Changes – Phase II (to date)

N/A

III. Financials

A. Total Phase II Contract: \$19,956,942

1. Fee Expended through November 30, 2024:

a) Total: \$11,667,112 (58.5%)

1) Basic Services: \$7,598,696 (38.1%)

2) Additional Services: \$4,068,417 (20.4%)

IV. Completed Workshops, Meetings and Visits (November—December)

A. Project Coordination Meeting w/ DWC – November 1, 2024

B. DWC and WaterLink Review Meeting w/ WIFIA – November 12, 2024

C. Re-Chlorination Facility Design Meeting w/ DWC – November 19, 2024

D. Monthly Progress Meeting w/ DWC – November 21, 2024

E. IL Route 71 Coordination Meeting w/ IDOT District 3 – November 25, 2024

V. Upcoming Tasks & Meetings

A. ComEd Coordination Meetings – Various

B. Phase II subsurface utility engineering (SUE) utility locating and potholing (ongoing).

C. Phase II topographic surveying and field data collection along final route (ongoing).

D. Phase II geotechnical field work (ongoing).

E. Field data collection for cathodic protection design (ongoing).

F. 90% Design Submittal – December 13, 2024.



Planning
Engineering
Program Management



Cash Flow/Invoicing Forecast - Phase II Services
DuPage Water Commission
WaterLink Extension
December 2024

Description	Activity through April 26, 2024	Activity through May 31, 2024	Activity through June 30, 2024	Activity through July 31, 2024	Activity through August 31, 2024	Activity through September 30, 2024	Activity through October 31, 2024	Activity through November 30, 2024	Planned	Planned	Planned	Planned	Planned	Planned	Planned	Planned	Planned
	May 2024	June 2024	July 2024	August 2024	September 2024	October 2024	November 2024	December 2024	January 2025	February 2025	March 2025	April 2025	May 2025	June 2025	July 2025	August 2025	September 2025
Basic Services	\$ 625,960	\$ 876,344	\$ 980,607	\$ 1,011,525	\$ 994,029	\$ 992,826	\$ 999,176	\$ 1,118,039	\$ 1,134,368	\$ 1,009,176	\$ 1,009,176	\$ 758,793	\$ 258,025	\$ 250,384	\$ 250,384	\$ 125,192	\$ 124,909
Additional Services	\$ 545,788	\$ 1,126,706	\$ 586,700	\$ 561,317	\$ 594,996	\$ 64,786	\$ 149,871	\$ 438,251	\$ 598,130	\$ 586,923	\$ 577,926	\$ 590,093	\$ 478,799	\$ 178,750	\$ 178,750	\$ 180,242	\$ -
MONTHLY SUBTOTAL	\$ 1,171,748	\$ 2,003,050	\$ 1,567,307	\$ 1,572,842	\$ 1,589,025	\$ 1,057,612	\$ 1,149,047	\$ 1,556,290	\$ 1,732,498	\$ 1,596,100	\$ 1,587,103	\$ 1,348,885	\$ 736,823	\$ 429,134	\$ 429,134	\$ 305,434	\$ 124,909
SUBTOTAL	\$6,314,947				\$5,351,974				\$8,290,021								
IGA ESCROW DEPOSITS	\$7,764,000				\$5,532,000				\$6,660,942								
TOTAL PHASE II CONTRACT															\$ 19,956,942		

**DuPage Water Commission
WaterLink Extension
Phase II Design Schedule**

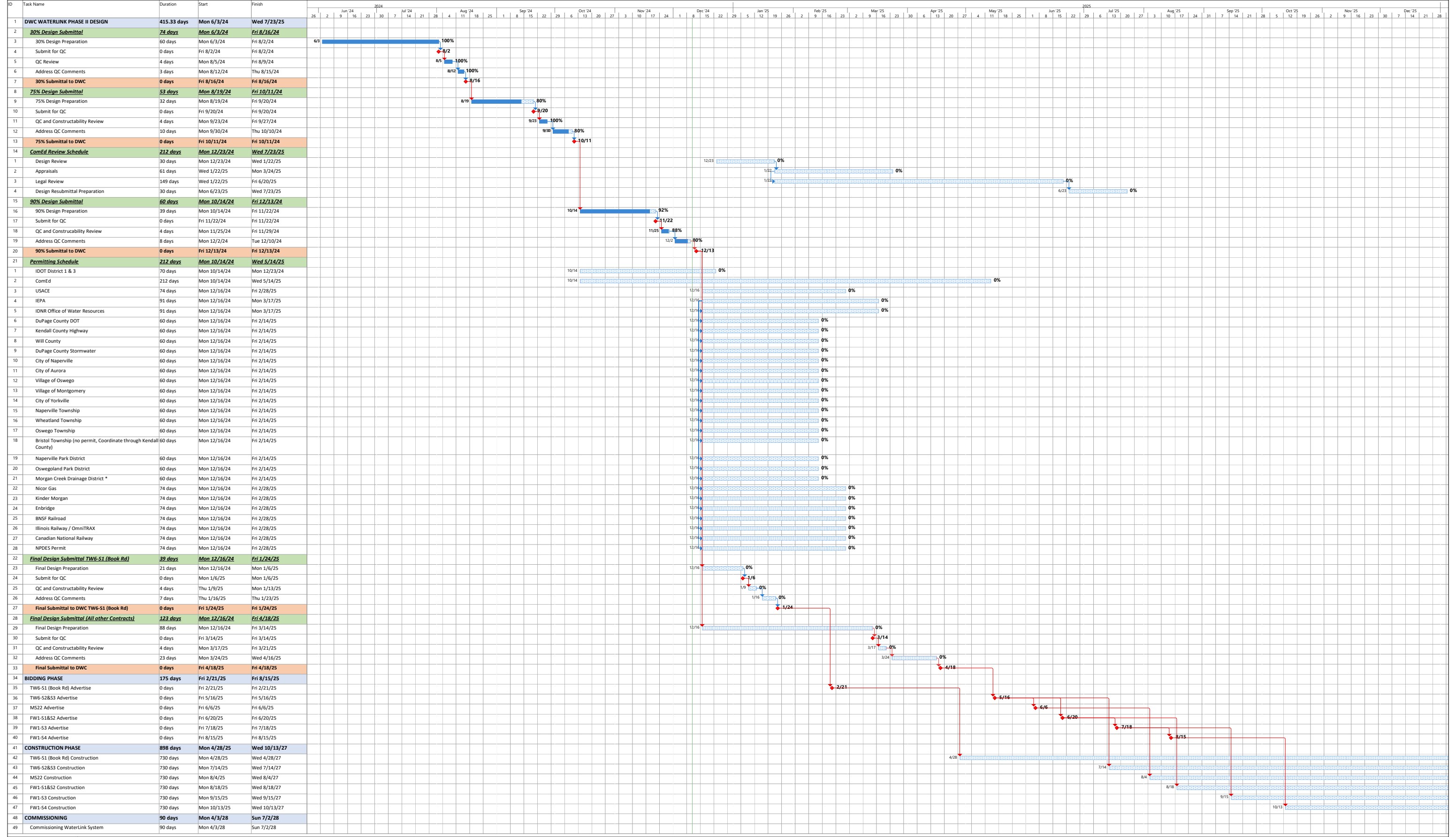

December 2024 Critical Task Task Progress
 Critical Progress Split Milestone



MONTHLY STATUS REPORT

LAN PROJECT #: 128-10031-001

PROJECT: DuPage Water Commission WaterLink Extension Phase II

REPORT DATE: January 7, 2025

MEETING DATE: January 16, 2025

I. Progress through January 7, 2025

A. Field data collection and surveying.

1. Subsurface Utility Locates

a) All remaining SUE field activities completed in mid-December.

2. Utility Potholing Locates

a) Over 440 potholes completed along ComEd corridors and are now 100% complete.

3. Geotechnical

a) Total of 167 borings (80%) completed to date in Phase 2 through January 3. Remaining borings along ComEd West corridor scheduled to be completed this week. Geotechnical boring logs and reports to follow in coming weeks.

4. Cathodic Protection

a) Soil resistivity testing along project routes nearing completion for cathodic protection design.

B. Data Collection (as-builts, GIS, design drawings).

1. WaterLink Delivery Point proposed site layouts.

2. Additional title commitments have been ordered along US Route 30, Wolf's Crossing, Douglas Rd.

3. Design team has set initial priority parcels to move to the plat preparation stage.

C. Ongoing Coordination with ComEd.

1. Approval for geotechnical and potholing work within ComEd property received on 11/5/24.

2. Approval/No exception email on revised alignment received on 11/5/24.

3. Subsequent ComEd design reviews and coordination will be performed during Phase II design as part of legal and appraisal process.



Planning
Engineering
Program Management





MONTHLY STATUS REPORT

D. Land Acquisition

1. 221 of 228 Titles Received
2. 186 total parcels for easement preparation
3. Easement legal descriptions & exhibits
 - a) 55 total prepared to date
4. Appraisals to begin in earnest this month.

E. Contract TW-6 Section 1 (Book Rd) in progress.

1. Water transmission main plan and profile design ongoing.
2. Proposed connection design at Book Road & 75th Street.
3. Remote operated valves to be placed along existing 48-inch transmission main.
4. Roadway plans and traffic control plans have been prepared.
5. In-field route review for valve locations completed to confirm actual conditions.
6. 90% Submittal Drawings submitted to DWC 12/13/24.
7. IEPA construction permit application submitted 1/3/25.

F. Contract TW-6 Section 2 & 3 in progress.

1. Water transmission main plan and profile design ongoing.
2. Alignment revision into Aurora 95th Street ROW was reviewed with the City and will not be pursued. 90% design will remain in ComEd ROW.
3. Realignment on 248th Avenue to accommodate two-way traffic during construction is complete.
4. In-field route review for valve locations completed to confirm actual conditions.
5. Tunnel locations reviewed based on DWC comments – one tunnel removed and one tunnel shortened on TW-6 Section 2.
6. Drawings to be submitted to ComEd week of 1/13/25 to initiate legal and real estate appraisal process.

G. Contract FW-1 Section 1 & 2 in progress.

1. Water transmission main plan and profile design ongoing.
2. 90% Submittal Drawings submitted to DWC 12/13/24.

H. Contract FW-1 Section 3 in progress.

1. Water transmission main plan and profile design ongoing.



Planning
Engineering
Program Management





MONTHLY STATUS REPORT

2. 90% Submittal Drawings Submitted to DWC 12/22/24.
3. Ongoing coordination with IDOT District 3 on IL Route 71 project overlap.
4. Permit application to IDOT District 3 will request several variances with regards to pipe alignment proximity to ROW line and drainage ditches. Permit application is being prepared.

I. Contract FW-1 Section 4 in progress.

1. Water transmission main plan and profile design ongoing.
2. 90% Submittal Drawings submitted to DWC 12/13/24.

J. Contract MS-22 Meter Stations in progress.

1. Meter station piping and building layouts ongoing.
2. WaterLink feedback received on architectural treatments and site layout modifications.
3. Architectural and structural design for the buildings is ongoing.
4. 90% Submittal Drawings to be submitted to DWC 1/17/25.

II. Scope Changes – Phase II (to date)

A. Design of Additional Architectural Treatments for WaterLink Meter Stations.

1. Fee: Pending (to be submitted to DWC for review/approval).

III. Financials

A. Total Phase II Contract: \$19,956,942

1. Fee Expended through December 31, 2024:
 - a) Total: \$13,133,293 (65.8%)
 - 1) Basic Services: \$8,714,697 (43.7%)
 - 2) Additional Services: \$4,418,598 (22.1%)

IV. Completed Workshops, Meetings and Visits (December – January)

- A. 248th Avenue Alignment Coordination Meeting – December 6, 2024
- B. Monthly Progress Meeting w/ DWC – December 19, 2024
- C. Yorkville and Montgomery Coordination Meeting – December 19, 2024
- D. City of Aurora Coordination Meeting – December 20, 2024



Planning
Engineering
Program Management





MONTHLY STATUS REPORT

V. Upcoming Tasks & Meetings

- A. ComEd Coordination Meetings – Various.
- B. Phase II geotechnical field work (ongoing).
- C. Field data collection for cathodic protection design (ongoing).
- D. Permit submittals to various review agencies.
- E. 90% Design Submittal to ComEd (TW-6 Section 2 & 3, FW-1 Section 4) – Week of January 13th
- F. 90% Design Submittal for Meter Stations – January 17, 2025.
- G. Final Design Submittal for TW-6 Section 1 – January 24, 2025.



Planning
Engineering
Program Management



**Cash Flow/Invoicing Forecast - Phase II Services
DuPage Water Commission
WaterLink Extension
January 2025**

Description	Activity through April 26, 2024	Activity through May 31, 2024	Activity through June 30, 2024	Activity through July 31, 2024	Activity through August 31, 2024	Activity through September 30, 2024	Activity through October 31, 2024	Activity through November 30, 2024	Activity through December 31, 2024	Planned	Planned	Planned	Planned	Planned	Planned	Planned	Planned
	May 2024	June 2024	July 2024	August 2024	September 2024	October 2024	November 2024	December 2024	January 2025	February 2025	March 2025	April 2025	May 2025	June 2025	July 2025	August 2025	September 2025
Basic Services	\$ 625,960	\$ 876,344	\$ 980,607	\$ 1,011,525	\$ 994,029	\$ 992,826	\$ 999,176	\$ 1,118,039	\$ 1,116,725	\$ 1,011,177	\$ 1,011,177	\$ 760,793	\$ 260,025	\$ 260,025	\$ 250,384	\$ 125,192	\$ 125,192
Additional Services	\$ 545,788	\$ 1,126,706	\$ 586,700	\$ 561,317	\$ 594,996	\$ 64,786	\$ 149,871	\$ 438,251	\$ 350,121	\$ 575,162	\$ 566,164	\$ 578,330	\$ 467,036	\$ 435,060	\$ 198,125	\$ 199,333	\$ -
MONTHLY SUBTOTAL	\$ 1,171,748	\$ 2,003,050	\$ 1,567,307	\$ 1,572,842	\$ 1,589,025	\$ 1,057,612	\$ 1,149,047	\$ 1,556,290	\$ 1,466,846	\$ 1,586,339	\$ 1,577,341	\$ 1,339,123	\$ 727,061	\$ 695,085	\$ 448,509	\$ 324,525	\$ 125,192
SUBTOTAL	\$6,314,947				\$5,351,974				\$8,290,021								
IGA ESCROW DEPOSITS	\$7,764,000				\$5,532,000				\$6,660,942								
TOTAL PHASE II CONTRACT															\$ 19,956,942		

**DuPage Water Commission
WaterLink Extension
Phase II Design Schedule**

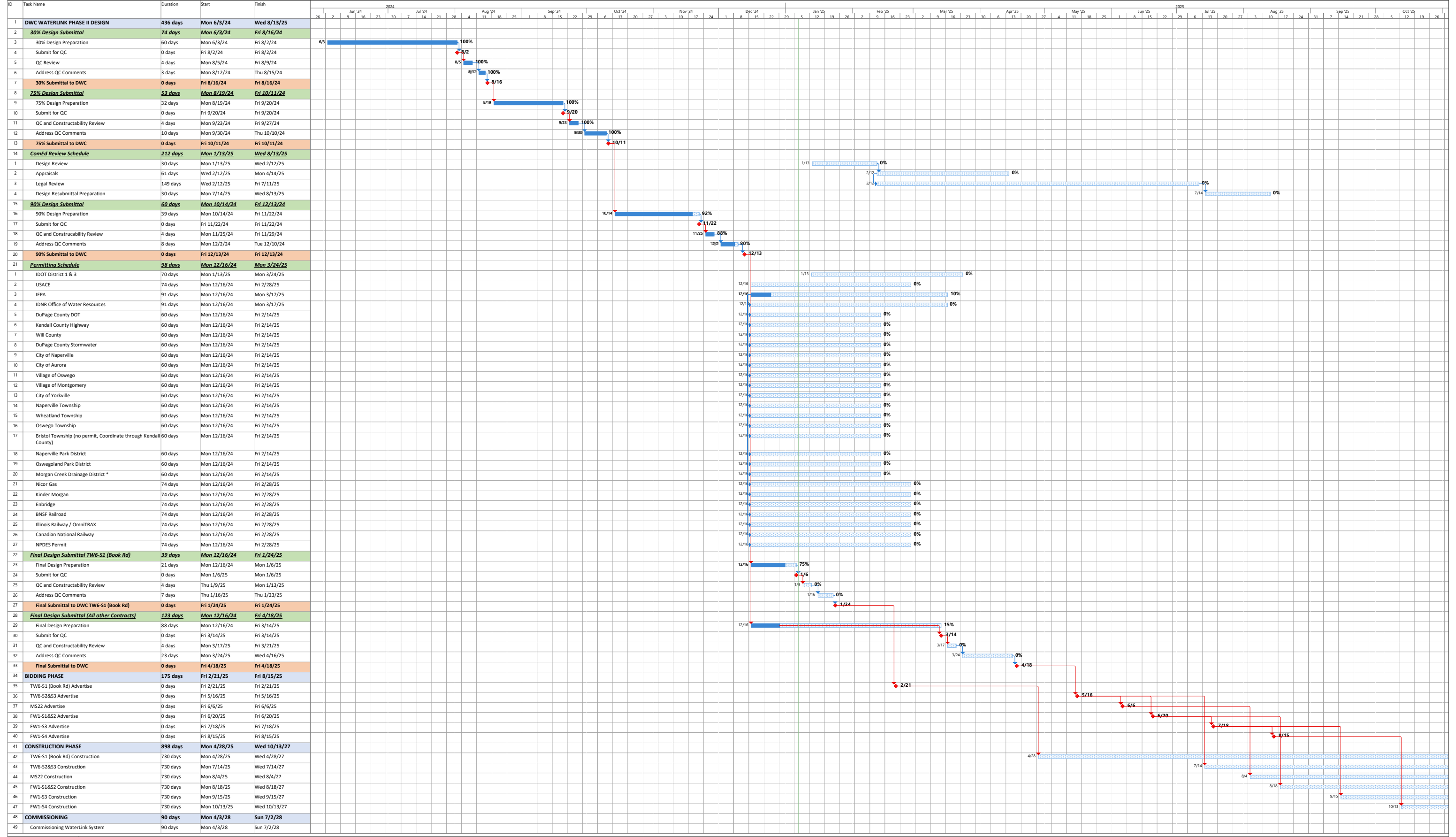

January 2025 Critical Task Task Progress



Resolution #: R-04-25

Account: 01-60-771700

Approvals: *Author / Manager / Finance / Admin*

DC RCB CAP PDM

REQUEST FOR BOARD ACTION

Date: 1/9/2025

Description: **A Resolution Approving the Purchase and Installation of Additional Security Cameras.**

Agenda Section: Engineering & Construction

Originating Department: Systems & Information Technology

The Commission recently replaced the campus security cameras, and during the upgrade process staff determined additional camera coverage was necessary in various locations that have blind spots. The locations of concern include the interior of the Service Yard Garage, the interior of the Vehicle Storage Building and the future reservoir site and storage yard. In anticipation of this proposal, this work was budgeted for under the CIP account 01-60-771700.

The interior of the Service Yard Garage and Vehicle Storage Building was requested to allow monitoring of the stored vehicles and large assets and provide visibility for operations staff. Regarding the future reservoir site and storage yard, additional cameras are requested to provide better visual coverage of stored materials and provide additional viewing angles of the entranceways.

The purchase and installation requests were made through Schneider Electric, the Commission's physical security support and maintenance contractor. With the inspection of these buildings and areas, and to allow for appropriate coverage, a recommendation for ten (10) additional cameras was given. The cameras all require additional cabling and headend network equipment, and the two cameras around the future reservoir site and storage yard require new security poles and mounting equipment. The proposal for this equipment includes the installation, configuration, and commissioning of the new camera systems as well as the integration into our existing video management system. The cost of the proposal comes to \$128,308.

Commission staff request authorization to purchase the hardware and utilize the professional services of Schneider Electric for the additional security cameras.

Recommended Motion: To approve Resolution No. R-04-25

DUPAGE WATER COMMISSION

RESOLUTION NO. R-04-25

A RESOLUTION
APPROVING THE PURCHASE AND INSTALLATION OF
ADDITIONAL SECURITY CAMERAS

WHEREAS, the Commission was formed and exists pursuant to the Water Commission Act of 1985, 70 ILCS 3720/0.01 et seq., and Division 135 of Article 11 of the Illinois Municipal Code, 65 ILCS 5/11-135-1 et seq., for the purpose of securing an adequate source and supply of water for its customers; and

WHEREAS, the DuPage Water Commission received a price quotation from Schneider Electric, dated December 12, 2024, in the amount of \$128,308 for the purchase and installation of ten (10) new security cameras, including ancillary equipment, poles, cabling and support as requested by Commission staff; and

WHEREAS, the Board of Commissioners of the DuPage Water Commission believes it is in the best interest of the Commission accept the price quotation offered by the Sole Source provider, Schneider Electric, to purchase and install the ten (10) new security cameras as requested by Commission staff;

NOW, THEREFORE, BE IT RESOLVED by the Board of Commissioners of the DuPage Water Commission as follows:

SECTION ONE: The foregoing recitals are incorporated herein and made a part hereof as findings of the Board of Commissioners of the DuPage Water Commission as if fully set forth.

SECTION TWO: The price quotation of Schneider Electric, dated as of December 12, 2024, for the purchase and installation of ten (10) new security cameras as requested by Commission staff shall be and hereby is approved and accepted by the Board of Commissioners of the DuPage Water Commission in the amount of \$128,308.00 necessary to effect the purchase of said hardware is hereby approved without further act.

SECTION THREE: This Resolution shall be in full force and effect from and after its adoption.

	Aye	Nay	Absent	Abstain
Bouckaert, D.				
Cuzzone, N.				
Fennell, J.				
VACANT	_____			
Novotny, D.				
Pruyn, J.				
Romano, K.				
Rush, K.				
Russo, D.				
Saverino, F.				
Suess, P.				
Van Vooren, D.				
Zay, J.				

ADOPTED THIS _____ DAY OF _____, 2025.

James F. Zay, Chairman

ATTEST:

Danna Mundall, Clerk
Board/Resolutions/2025/R-04-25.docx

EXHIBIT 1

December 12 10th, 2024

Mr. Denis Cuvalo
DuPage Water Commission
600 E. Butterfield Road
Elmhurst, IL 60126

Proposal # DEB-23-118

Re: **DuPage Water Commission – DWC 2 Garages and Back Parking Camera Adds**

Dear Denis

Thank you for allowing Schneider Electric (SE) the opportunity to present this proposal for your security concerns. I respectfully submit the following for your review.

Objective: Install Security Cameras inside the Pump Station Garage, Back Storage Garage and in the Back Storage Area Parking lot.

Schneider Electric will provide the following:

- Purchase & Install Concrete Form/Footing & anchors. Diameter and Depth to be determined by Schneider Electric's Sub.
- Ground pole in accordance with NEC guidelines
- Purchase & Install Directional bore and trenching to run conduits to pole locations Qty (2). Distance and depth to be determined by Schneider Electric's Sub.
- Purchase & Install (2) security poles 20' long with a 4" square bases.
- Purchase & Install Conduit for Security cabling from Back Storage Garage to feed (2) new poles/cameras.
- Purchase & Install Category Cabling for Qty (1) new cameras outside on the new Poles, Connect back to the Switch inside Back Storage Garage. Location is East of the Garage
- Purchase & Install Paige Gamechanger Cabling for Qty (1) new cameras outside on the new Poles, Connect back to the Switch inside Back Storage Garage. Location is on the SW corner
- Purchase, Mount and position Qty (2) cameras Outside Back Storage Building parking lot
- Provide and procure the pole Alignment with Municipalities
- Provide Lift
- Purchase & Install Conduit from Switch to each camera location located inside the Back Storage Garage. Qty (4) Cameras.
- Purchase & Install Category Cabling for Qty (4) new cameras inside Back Storage Building. Connect back to the Switch inside the Storage Garage.
- Purchase, Mount and position Qty (4) cameras inside Back Storage Building.
- Purchase & Install Conduit from Switch to each camera location located inside Pump Garage. Qty (4) Cameras.

- Purchase & Install Category Cabling for Qty (4) new cameras inside Pump Garage. Connect back to the Switch inside the Storage Garage.
- Purchase & Install Qty (4) Cisco Catalyst 1000-8P-E-2G-Lcameras inside Pump Garage.
- Purchase and Install Qty (10) Device Licenses and 2 Year Care Professional.
- Purchase & Install Fiber cable from New Switch in Pump Garage back to Switch in the Generator Building.
- Trim, terminate and test all cabling.
- All cable and wire will be labeled with ID code at switch end and at camera end.
- Schneider Electric Technicians for Device Installation/ Mounting / Positioning
- Schneider Electric Technician & Software Engineer for Testing / Commissioning
- Schneider Electric Software Engineer for Programming
- Schneider Electric IT for configuration on Cisco Switch
- Project Management & Coordination

PROPOSAL PRICE:

\$ 128,308.00

NVR Add-On Server Information:

IP Cameras:	10
Camera Data Rate:	39.57 Mbps
Storage Data Rate:	23.08 Mbps
Storage Required:	2.13 TB

Clarifications:

1. The pricing quote is per Schneider Electric scope/clarifications herein. Price(s) cover only materials and services herein based on our interpretation of requirements
2. Schneider provides our own in-house Union “C” card Electricians, additional costs will apply if any special site conditions agreements prevail.
3. All work has been priced for work being completed at the same time during one continuous mobilization.
4. Schneider Electric has not factored in any phasing per breakout price, Schneider Electric assumes to be able to complete the project in one phase. Any remobilization costs due to phasing per breakout price, may be subject to additional fees.
5. One-year labor and part warranty on new equipment and labor.
6. Any adds, moves, changes or additions will be provided at additional cost.
7. All Labor has been bid at straight time, first shift work Monday – Friday 7:00 am – 3:30pm.
8. Outside Work should be done before or after ground freezing season.
9. The diameter and depth of the concrete Form/Footing to be determined by Schneider Electric’s Sub.
10. The dimensions of Qty (2) Security poles are 20’ long with a 4” square bases.

11. With the SCADA project getting a new NVR, the VMS should be sufficient after adding the Stats listed above under Section “**NVR Add-On Server Information:**”
12. The current NVR can take the added configuration, but it would not work at optimum performance.
13. Schneider Electric will not do any soil removal or soil testing.

Exclusions & Exceptions:

1. Schneider is unaware of any required permits or inspections normally required for work of this type and have not included any costs in our proposal. Should any Authority having Jurisdiction (AHJ) come forward and require any item that has cost; it shall be added to the project value as a change order.
2. Schneider Electric has no MBE/WEBE participation in this proposal.
3. No Ballard’s are needed on this project.
4. No permits are included in this project.

* Taxes – The prices quoted herein does not include Federal, State, County, City, Sales, Use, Excise, Import, Export, or other similar taxes.

Pricing terms set forth in this proposal shall remain firm only for a period of 30 days.

This quote or proposal is submitted subject to and conditioned upon the terms and conditions being subsequently agreed to between the parties.

If you have any questions, please call me at (630)205-4818.

Sincerely,

Don Bachman

Don Bachman
Service Sales Representative
Schneider Electric Buildings Business
Don.bachman1@se.com

Firm: _____

Accepted by: _____

Title: _____

Date: _____

TERMS AND CONDITIONS OF SALE

900512PITC R07/15/21

This quotation and any exhibits and attachments hereto (collectively, "Agreement") and any information contained herein, is the property of Schneider Electric Buildings Americas Inc. ("Company") and shall constitute proprietary and confidential information unless given to a public entity and required by law to be public information. The party to whom this quotation is addressed ("Customer") acknowledges the confidential nature of this Agreement and agrees to take all commercially reasonable and necessary precautions to ensure the confidential treatment of this Agreement and all information contained herein. This Agreement will not be used, copied, reproduced, disclosed or otherwise disseminated or made available, directly or indirectly, to any third party for any purpose whatsoever without the prior written consent of Company. The parties agree to be bound by the following terms and conditions.

- 1. Quotations and Acceptance.** The quotation is based solely on the bid documents, which consist of the project drawings, specifications and/or instructions of the Customer only modified by written agreement or Company objection. Significant deviations between the actual conditions and circumstances of the work and those specified in the bid documents shall be cause for an adjustment in work scope, price and time allowed for performance. Written quotations shall be valid for no more than thirty (30) days from the date of issue, unless specifically stated otherwise herein. Customer may accept the quotation by signing and returning a copy to Company or by returning Customer's own written instrument or order expressly acknowledging the quotation and terms set forth herein, provided, however, Company hereby gives notice of its objection to any different or additional terms or conditions contained or referenced in Customer's order, which will be of no force or effect except as may be expressly agreed to by Company in writing. It is the intent of the parties that these Terms and Conditions of Sale shall govern the sale of goods delivered and services performed. Upon acceptance, this Agreement constitutes the entire understanding between the parties respecting the goods or services delineated herein and supersedes all prior oral or written understandings or representations relating to such goods or services. This Agreement may not be discharged, extended, amended or modified in any way except by a written instrument signed by a duly authorized representative of each party. Company assumes that the Subcontract Agreement offered will contain terms that are substantively similar to the AIA provisions that are in accordance with the provisions of the prime contract, including any supplements. Upon award, Company assumes that contract provisions will be reviewed and negotiated in good faith to reach a mutual acceptance of both parties.
- 2. Payment.** Absent a contrary provision herein, Customer will pay Company monthly progress payments on a net thirty (30) days basis from date of invoice for materials delivered (or stored at an off-site storage facility) and services performed, less any retained reserve which will be mutually agreed upon in writing by the parties. The aggregate amount of any such retained reserves shall be paid by Customer to Company within thirty (30) days after the date of substantial completion. If Company provides a Certificate of Substantial Completion, such certificate shall conclusively establish such date. All invoices due and payable to Company, less any applicable retained reserve, shall accrue interest at a compounded per annum rate not to exceed 1½% per month (18% per annum) or the maximum rate permitted by law. Acceptance and endorsement by Company of an instrument for less than the full amount which Company claims to be due shall not be deemed to be an admission of payment in full and any conditions to the contrary which are noted on such an instrument shall not be binding on Company. If Customer does not pay Company, through no fault of Company, within seven (7) days from the time payment was due, Company may, without prejudice to any other remedy it may have, upon seven (7) additional days' written notice to Customer, stop its work until payment of the amount owing has been received and the contract sum shall be equitably adjusted for reasonable costs of shutdown, delay and startup or in the alternative Company may terminate this contract for material breach and all monies due Company for services performed and materials delivered shall be paid upon demand. Company shall be entitled to recover from Customer all costs for collection, including reasonable attorneys' and professionals' fees. To the extent payments are received and as required by law, and upon Customer's request, Company will furnish lien waivers as the work progresses.

Company reserves a security interest in any goods sold to the extent of the invoiced amount to secure payment of Customer's obligation. In event of payment default, Company may repossess such goods and a copy of the invoice may be filed with appropriate authorities as a financing statement to event or perfect Company's security interest in the goods. At Company's request, Customer will execute any necessary instrument to perfect Company's security interest.
- 3. Price and Taxes.** The price for the goods and services hereunder are those shown on the face of this Agreement. The price of this Agreement does not include sales, use, excise, duties or other similar taxes, unless otherwise expressly provided herein. Any taxes (other than taxes due on Company's net income) that are payable hereunder shall be the responsibility of Customer. If applicable, Customer shall provide Company a copy of any appropriate tax exemption certificate for the state(s) into which the goods are to be shipped.
- 4. Changes and Claims.** All materials and labor furnished hereunder shall be in accordance with shop drawings submitted by Company and approved by Customer. Any changes in the work as set forth in approved shop drawings, or from the scope of work as described herein, will require a written change order submitted to Company by Customer. An equitable adjustment will be made in the contract price or delivery dates or both, and this Agreement will be modified accordingly in writing. The cost or credit to Customer for performance of such change order shall be determined by mutual written agreement prior to the commencement of any work under such change order. Customer shall notify Company promptly in writing of any circumstances arising from the performance of the work herein described which reasonably may be anticipated to result in a claim or back charge to Company. Upon Company's receipt of such notification, Company shall have five (5) working days in which to remedy such circumstances and to avoid the imposition of such claim or back charge. Company will not be liable for any claim or back charge where Company has not been notified in the manner as set forth above.
- 5. Access and Overtime.** This Agreement is based upon the use of straight time labor only during regular working hours (8:00 a.m. to 5:00 p.m., Monday through Friday, excluding Company's holidays). If Customer requests Company to perform any work outside of regular working hours, overtime and other additional expense occasioned thereby will be charged to and paid by Customer. If Company's work is to be performed on the project site, Customer will afford unrestricted access to Company and its employees and agents to all work areas.
- 6. Damage or Loss to Equipment.** In the case of equipment not to be installed by or under supervision of Company, Company shall not be liable for damage to or loss of equipment after delivery of such equipment to the point of shipment. In the case of equipment to be installed by or under supervision of Company, Company shall not be liable for damage or loss after delivery by the carrier to the site of installation; if thereafter, pending installation or completion of installation or full performance by Company, any such equipment is damaged or destroyed by any cause whatsoever, other than by the fault of Company, Customer agrees to promptly pay or reimburse Company an amount equal to the damage or loss which Company incurs as a result thereof, in addition to or apart from, any and all other sums due or to become due hereunder.
- 7. Delays.** Customer shall prepare all work areas so as to be acceptable for Company's work required hereunder. Customer acknowledges that the

contract sum is based upon Company being able to perform the work in an orderly and sequential manner, as Company so determines. If Company's performance is delayed, interfered with, suspended, or otherwise interrupted, in whole or in part, by Customer, other contractors on the project site, or by any other third party or by any act within the power and/or duty of Customer to control, then Customer agrees that it will be liable to Company for all increased costs and damages which Company incurs as a result thereof. Furthermore, if Company is delayed at any time in the progress of the work by any act or neglect of Customer, or by any separate contractor employed by Customer, or by changes ordered in the work or by labor disputes, fire, delay in transportation, adverse weather conditions, casualties, or any other causes beyond Company's control, then the time for completion of the work shall be extended for a period equal to the time lost by reason of such delay.

8. **Warranty.** Company warrants to Customer that all tangible articles manufactured by Company will be free of defects in workmanship and material and that the work performed will be of good quality and will conform to the requirements of the bid documents. If the article is installed by Company, Company's sole obligation under this warranty shall be to provide, without charge, parts and labor necessary to remedy defects which appear within twelve (12) months from the date of beneficial use or occupancy, as applicable. If Company provides a Certificate of Substantial Completion, such certificate shall conclusively establish such date. If article is not installed by Company, the warranty period shall be within twelve (12) months of shipment of said article. Warranty claim must be made to Company in writing within such twelve (12) month period. All transportation charges incurred in connection with the warranty for equipment not installed by Company shall be borne by Customer. Company warrants that for equipment furnished and or installed, but not manufactured by Company, Company will extend the same warranty terms and conditions which Company receives from the manufacturer of said equipment. This warranty is the sole and exclusive warranty given with respect to any articles delivered or services performed by Company. THE WARRANTIES SET FORTH ABOVE ARE EXCLUSIVE AND IN LIEU OF ALL OTHER WARRANTIES EXPRESS OR IMPLIED (EXCEPT WARRANTIES OF TITLE), INCLUDING, BUT NOT LIMITED TO, WARRANTIES OF

MERCHANTABILITY AND FITNESS FOR A PARTICULAR PURPOSE. This warranty is subject to proper installation of the articles (if installation is not performed by Company or authorized subcontractors of the Company) and maintenance and storage of the articles in accordance with the specifications and directions supplied by Company. This warranty does not apply to any defect, malfunction or failure caused by repairs made by other than or without the consent of Company or the article has been subject to abuse, misuse, neglect, tampering, accident or damage by circumstances beyond Company's control, including without limitation, acts of God, war, acts of government, corrosion, power fluctuations, freeze-ups, labor disputes, differences with workmen, riots, explosions, vandalism, or malicious mischief, nor to defective associated equipment or use of the articles with equipment for which they were not sold. All of Company's obligations under this warranty will immediately terminate and be of no further force or effect if all or any part of the purchase price (including any installment payment) with respect to any article covered by this warranty is not paid to Company when due. If cause of defect is found not to be Company's responsibility, standard rates for repair or replacement and labor shall apply.

9. **Limitation of Liability.** In no event will Company's total aggregate liability in warranty or contract exceed the contract price paid for the specific product or service that gives rise to the claim excluding third party claims for personal injury, death or as may be required by law. IN NO EVENT SHALL COMPANY BE LIABLE FOR ANY LOST PROFITS, LOSS OF USE, DATA, LOSS OF GOODWILL, BUSINESS INTERRUPTION OR ANY OTHER SPECIAL, INDIRECT, INCIDENTAL, PUNITIVE OR CONSEQUENTIAL DAMAGES OF ANY KIND EVEN IF COMPANY HAS BEEN ADVISED OF THE POSSIBILITY OF SUCH DAMAGES.
10. **Laws and Permits.** Company shall comply with all applicable federal, state, and local laws and regulation and shall obtain all temporary licenses and permits required for the prosecution of the work. Licenses and permits of a permanent nature shall be procured and paid for by the Customer. This contract shall be interpreted and governed under and in accordance with the laws of the jurisdiction in which the goods are delivered or services are performed without regard to its choice of law provisions.
11. **Disputes.** Any controversy or claim arising out of or relating to this Contract, or the breach thereof, shall be settled by good faith consultation and negotiation. If those attempts fail, either party shall provide written notice within thirty (30) days to the other to mutually agree on an arbitration process. If a process is not agreed upon within thirty (30) days, final and binding arbitration in accordance with the then current Construction Industry Arbitration Rules of the American Arbitration Association shall commence and judgment upon the award rendered may be entered in any court having jurisdiction thereof. The arbitration shall be held in the federal, state or municipal courts serving the county in which the project is located unless the parties mutually agree otherwise. The prevailing party shall recover all reasonable legal costs and attorney's fees incurred as a result, which shall be promptly paid by the non-prevailing party. Any dispute or demand for arbitration must be commenced within one (1) year after the cause of action has accrued. Nothing herein shall limit any rights Company may have under construction mechanic or materialmen lien laws. Company shall have the right to suspend affected services pending resolution of disputes.
12. **Insurance.** The parties shall each maintain insurance coverage including without limitation, Workers' Compensation and Employer's Liability at statutory limits, Automobile Liability covering all owned, hired and other non-owned vehicles, and Commercial General Liability covering public liability and property damage with limits generally required for its respective industry with not less than \$1,000,000 minimum coverage per occurrence. Such insurance shall be with reputable and financially responsible carriers authorized to transact business in the jurisdiction in which the project and services are being performed. No credit will be given or premium paid by Company for insurance afforded by others.
13. **Clean Up.** Company agrees to keep the job site clean of debris arising out of its operations. Customer shall not back charge Company for any costs or expenses for clean up or otherwise without prior written notice and Company's written consent.
14. **Severability.** The invalidity or unenforceability of any provision herein shall in no way affect the validity or enforceability of any other provision.
15. **Disclaimer.** Company reserves the right to amend, withdraw or otherwise alter this submission without penalty or charge as a result of any event beyond its control arising from or due to the current COVID-19 epidemic or events subsequent to this epidemic / pandemic including changes in laws, regulations, by laws or direction from a competent authority. The Customer acknowledges that the products or part thereof are produced in, or otherwise sourced from, or will be installed areas already affected by, or that may be affected in the future by, the prevailing COVID-19 epidemics/pandemic and that the situation may trigger stoppage, hindrance or delays in Company's (or its subcontractors) capacity to produce, deliver, install or service the products, irrespective of whether such stoppage, hindrance or delays are due to measures imposed by authorities or deliberately implemented by the Company (or its subcontractors) as preventive or curative measures to avoid harmful contamination exposure of Company's (or its subcontractors') employees. The Customer therefore recognizes that such circumstances shall be considered as a cause for excusable delay not exposing the Company to contractual sanctions including without limitation delay penalties, liquidated or other damages or termination for default.

16. **Ethics and Compliance with Laws.** Each party shall comply in all respects with all applicable legal requirements governing the duties, obligations, and business practices of that party. Neither party shall take any action in violation of any applicable legal requirement that could result in liability being imposed on the other party. In the event Customer has concerns related to ethics, compliance, or Company's Principles of Responsibility, and/or any potential violations of these policies, Customer is welcome to make use of Company's GreenLine. The GreenLine is Company's global helpline for external stakeholders. It is a confidential channel through which Customers can ask questions and raise concerns. Reports can be made using the link: <https://secure.ethicspoint.eu/domain/media/en/gui/104677/index.html>.
17. **Cybersecurity.**
- 17.1. Customer's Obligations for Its Systems: Customer is solely responsible for the implementation and maintenance of a comprehensive security program ("Security Program") that contains reasonable and appropriate security measures and safeguards to protect its computer network, systems, machines, and data (collectively, "Systems"), including those Systems on which it runs the Products or Services provided by Company, against Cyber Threats. "Cyber Threat" means any circumstance or event with the potential to adversely impact, compromise, damage, or disrupt Customer's Systems or that may result in any unauthorized access, acquisition, loss, misuse, destruction, disclosure, and/or modification of Customer's Systems, including any data, including through malware, hacking, or similar attacks.
- 17.2. Without limiting the foregoing, Customer shall at a minimum:
- (a) have qualified and experienced personnel with appropriate expertise in cybersecurity maintain Customer's Security Program, and have such personnel regularly monitor cyber intelligence feeds and security advisories applicable to Customer's Systems or Customer's industry;
 - (b) promptly update or patch its Systems or implement other appropriate measures based on any reported Cyber Threats and in compliance with any security notifications or bulletins, whether publicly disclosed on Company's security notification webpage at <https://www.se.com/ww/en/work/support/cybersecurity/security-notifications.jsp> or otherwise provided to Customer;
 - (c) regularly monitor its Systems for possible Cyber Threats;
 - (d) regularly conduct vulnerability scanning, penetration testing, intrusion scanning, and other cybersecurity testing on its Systems; and meet the recommendations of Company's Recommended Cybersecurity Best Practices, available at <https://www.se.com/us/en/download/document/7EN52-0390/>, as may be updated by Company from time to time, and then-current industry standards.
- 17.3. Customer's Use of the Products, Software, and Services: Company may release Updates and Patches for its Products, Software, and Services from time to time. Customer shall promptly install any Updates and Patches for such Products, Software, or Services as soon as they are available in accordance with Company's installation instructions and using the latest version of the Products or Software, where applicable. An "Update" means any software that contains a correction of errors in a Product, Software, or Service and/or minor enhancements or improvements for a Product, Software, or Service, but does not contain significant new features. A "Patch" is an Update that fixes a vulnerability in a Product, Software, or Service. Customer understands that failing to promptly and properly install Updates or Patches for the Products, Software, or Services may result in the Products, Software, or Services or Customer's Systems becoming vulnerable to certain Cyber Threats or result in impaired functionality, and Company shall not be liable or responsible for any losses or damages that may result.
- 17.4. Identification of Cyber Threats: If Customer identifies or otherwise becomes aware of any vulnerabilities or other Cyber Threats relating to the Products, Software, or Services for which Company has not released a Patch, Customer shall promptly notify Company of such vulnerability or other Cyber Threat(s) via the Company's Report a Vulnerability page (<https://www.se.com/ww/en/work/support/cybersecurity/report-a-vulnerability.jsp#Customers>) and further provide Company with any reasonably requested information relating to such vulnerability (collectively, "Feedback"). Company shall have a non-exclusive, perpetual and irrevocable right to use, display, reproduce, modify, and distribute the Feedback (including any confidential information or intellectual property contained therein) in whole or part, including to analyze and fix the vulnerability, to create Patches or Updates for its customers, and to otherwise modify its Products, Software, or Services, in any manner without restrictions, and without any obligation of attribution or compensation to Customer; provided, however, Company shall not publicly disclose Customer's name in connection with such use or the Feedback (unless Customer consents otherwise). By submitting Feedback, Customer represents and warrants to Company that Customer has all necessary rights in and to such Feedback and all information it contains, including to grant the rights to Company described herein, and that such Feedback does not infringe any proprietary or other rights of third parties or contain any unlawful information.
18. **Import and Export.**
- 18.1. The Products and Services provided by Company under this Contract contain or may contain components and/or technologies from the United States of America ("US"), the European Union ("EU") and/or other nations. Customer acknowledges and agrees that the Products, assignment and/or usage of the Products, Software, Services, information, other deliverables and/or the embedded technologies
- 18.2. (hereinafter referred to as "Deliverables") under these Terms and Conditions of Sale shall fully comply with related applicable US, EU and other national and international export control laws and/or regulations.
- 18.3. Unless applicable export license/s has been obtained from the relevant authority and Company has approved, the Deliverables shall not (i) be exported and/or re-exported to any destination and party (may include but not limited to an individual, group and/or legal entity) restricted by the applicable export control laws and/or regulations; or (ii) be used for those purposes and fields restricted by the applicable export control laws and/or regulations. Customer also agrees that the Deliverables will not be used either directly or indirectly in any rocket systems or unmanned air vehicles; nor be used in any nuclear weapons delivery systems; and will not be used in any design,

- 18.4. development, production or use for any weapons which may include but not limited to chemical, biological or nuclear weapons.
- 18.5. If any necessary or advisable licenses, authorizations or approvals are not obtained, whether arising from inaction by any relevant government authority or otherwise, or if any such licenses, authorizations or approvals are denied or revoked, or if the applicable export control laws and/or regulations would prohibit Company from fulfilling any order, or would in Company's judgment otherwise expose Company to a risk of liability under the applicable export control laws and/or regulations if it fulfilled the order, Company shall be excused from all obligations under such order and/or these Terms and Conditions of Sale.



Resolution #: R-06-25

Account: 01-60-662100 01-60-771200
- NTE \$100,000

Approvals: *Author / Manager / Finance / Admin*

MW RCB CAP PDM

REQUEST FOR BOARD ACTION

Date: 1/9/2025

Description: A Resolution Authorizing the General Manager to Purchase Material and Labor Services for the High-Lift Pump Motors including Ancillary Equipment, at a cost not-to-exceed \$100,000 from WEG Electric Machinery

Agenda Section: Engineering & Construction

Originating Department: Operations & Instrumentation

WEG Electric Machinery (EM) is the Original Equipment Manufacturer (OEM) of the nine (9) High-Lift Pump Motors at the DuPage Pumping Station. EM provides total product support including OEM factory-trained technicians, customer service and support associated with all EM Products.

Resolution No. R-06-25 would authorize the General Manager to purchase material and labor service including ancillary equipment at a cost not-to-exceed \$100,000 from WEG Electric Machinery, as a sole source provider, by issuance of Purchase Order(s).

Recommended Motion:

To approve Resolution No. R-06-25

RESOLUTION NO. R-06-25

A RESOLUTION AUTHORIZING THE GENERAL MANAGER TO PURCHASE MATERIAL AND LABOR SERVICE FOR THE COMMISSION'S LARGE ELECTRICAL MOTOR SYSTEMS INCLUDING ANCILLARY EQUIPMENT, AT A COST NOT-TO-EXCEED \$100,000 FROM WEG ELECTRIC MACHINERY

WHEREAS, the DuPage Water Commission operates nine (9) High-Lift Pump Motors at the DuPage Pumping Station which provide mechanical power to operate the pumping system; and

WHEREAS, WEG Electric Machinery is the Original Equipment Manufacturer (OEM) of the High-Lift Pump Motors; and

WHEREAS, WEG Electric Machinery provides factory-trained technicians, customer service and support associated with Electric Machinery products; and

WHEREAS, Material and labor services would be used on an as needed basis through the issuance of Purchase Orders; and

WHEREAS, the Board of Commissioners of the DuPage Water Commission believes it is in the best interest of the Commission to authorize the General Manager to purchase material and labor services at a cost not-to-exceed \$100,000 from WEG Electric Machinery, a Sole Source provider;

NOW, THEREFORE, BE IT RESOLVED by the Board of Commissioners of the DuPage Water Commission as follows:

SECTION ONE: The foregoing recitals are incorporated herein and made a part hereof as findings of the Board of Commissioners of the DuPage Water Commission as if fully set forth.

SECTION TWO: The General Manager's authority to purchase material and labor service from a sole source provider for the Commission's High-Lift Pump Motors from WEG Electric Machinery to be and hereby is approved and accepted by the Board of Commissioners of the DuPage Water Commission without further act.

SECTION THREE: This Resolution shall be in full force and effect from and after its adoption.

	Aye	Nay	Absent	Abstain
Bouckaert, D.				
Cuzzone, N.				
Fennell, J.				
VACANT	_____			
Novotny, D.				
Pruyn, J.				
Romano, K.				
Rush, K.				
Russo, D.				
Saverino, F.				
Suess, P.				
Van Vooren, D.				
Zay, J.				

ADOPTED THIS _____ DAY OF _____, 2025.

James F. Zay, Chairman

ATTEST:

Danna Mundall, Clerk
Board/Resolutions/2025/R-06-25.docx



Resolution #: R-07-25

Account: 01-60-628000

Approvals: *Author / Manager / Finance / Admin*

RCB RCB CAP PDM

REQUEST FOR BOARD ACTION

Date: 1/9/2025

Description: A Resolution Authorizing Classen, White and Associates to Perform Surveying Services in Relation to the Commission's Hydraulic Model

Agenda Section: Engineering & Construction

Originating Department: Administration

Burns and McDonnell Engineering, upon receiving the Commission's hydraulic model, determined that thirteen (13) nodes within the Commission's distribution system model appear to reflect inaccurate USGS based pipeline and meter station elevation data upon which the output of the hydraulic model data is predicated on.

Therefore, staff are seeking authorization to utilize Classen, White & Associates, P.C., to perform surveying services to establish accurate pipeline elevations to be incorporated into the hydraulic model, as well as proving benchmarks at each of the thirteen locations for future reference.

Classen, White and Associates, P.C. have been satisfactorily performing survey services directly for the Commission or as a subconsultant for several of the Commission's MSA consulting firms on several discreet projects over a span of many years and we would like to maintain continuity of the services previously provided. Classen, White and Associates will perform the work at an estimated cost based upon actual hours worked; not-to-exceed \$34,019.00.

Recommended Motion:

To adopt R-07-25

DUPAGE WATER COMMISSION

RESOLUTION NO. R-07-25

A RESOLUTION AUTHORIZING CLASSEN, WHITE AND ASSOCIATES TO PERFORM SURVEYING SERVICES IN RELATION TO THE COMMISSION'S HYDRAULIC MODEL

WHEREAS, the Commission was formed and exists pursuant to the Water Commission Act of 1985, 70 ILCS 3720/0.01 et seq., and Division 135 of Article 11 of the Illinois Municipal Code, 65 ILCS 5/11-135-1 et seq., for the purpose of securing an adequate source and supply of water for its customers; and

WHEREAS, the Commission desires to obtain professional surveying services in connection with the hydraulic model update as delineated by the Commission; and

WHEREAS, for ease of administration, the Commission and Consultant desire to provide professional surveying services for the hydraulic model update; and

NOW, THEREFORE, BE IT RESOLVED by the Board of Commissioners of the DuPage Water Commission as follows:

SECTION ONE: The foregoing recitals are hereby incorporated herein and made a part hereof as findings of the Board of Commissioners of the DuPage Water Commission.

SECTION TWO: Professional Services attached hereto and by this reference incorporated herein and made a part hereof as Exhibit 1, with such modifications as may be required or approved by the General Manager of the Commission, shall be and hereby is approved and the General Manager shall be and hereby is authorized and directed to execute the Agreement in substantially the form attached hereto as Exhibit 1 with such modifications as may be required or approved by the General Manager.

SECTION THREE: This Resolution shall be in full force and effect from and after its adoption.

	Aye	Nay	Absent	Abstain
Bouckaert, D.				
Cuzzone, N.				
Fennell, J.				
VACANT	_____			
Novotny, D.				
Pruyn, J.				
Romano, K.				
Rush, K.				
Russo, D.				
Saverino, F.				
Suess, P.				
Van Vooren, D.				
Zay, J.				

ADOPTED THIS _____ DAY OF _____, 2025.

James F. Zay, Chairman

ATTEST:

Danna Mundall, Clerk

Board/Resolutions/2025/R-07-25.docx

EXHIBIT 1

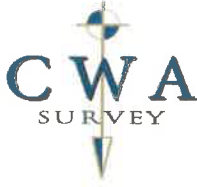

Claassen, White & Associates, P.C.

LAND SURVEYORS
121 Airport Drive, Unit I, Joliet, Illinois 60431
(815) 744-3720 office (815) 744-3752 fax
claassenwhite@cwasurevey.com

DBE & WBE certified
IDOT prequalified in Special Services (Surveying)

RHONDA J. WHITE, PLS
President

DAVID A. CLAASSEN, PLS
Vice-President

November 11, 2024
Chris Bostick
DuPage Water Commission
13 Metering Sites (Various Locations)

Scope of Services

Establish benchmarks and pipe elevations at 13 select metering site locations per map and e-mail dated November 7, 2024 to include the following:

- Will set 13 new brass monuments (1 per site) at the top of slab elevation with permanent elevation affixed.
- Vertical Control per NAVD 88 datum per NGS monuments, all benchmarks will be digitally leveled.
- Will provide Illinois State Plane Coordinates / East Zone NAD83(2011) on the 13 Brass Monuments.
- Will provide a data sheet for all 13 new benchmarks (see attached example).
- Will provide field notes and spread sheet for centerline elevation of the inlet pipe located in the sub-structure of the metering site.

Cost: **\$34,019.00** (Billed on an hourly basis per attached CECS, not to exceed)

Thank you for the opportunity to provide you with this estimate. If you have any questions or comments, please do not hesitate to call. If you accept this proposal, please sign, date and return this agreement.

Sincerely,

David A. Claassen, PLS
Vice President

Agreement by (signature):

Dated:

Print Name and Title:

PAYROLL ESCALATION TABLE FIXED RAISES

FIRM NAME
PRIME/SUPPLEMENT
Prepared By

Claassen, White & Associates,
Prime
David A. Claassen

DATE 11/11/24
PTB-ITEM# 1

CONTRACT TERM 6 MONTHS
START DATE 12/1/2024
RAISE DATE 6/1/2025

OVERHEAD RATE 114.76%
COMPLEXITY FACTOR 0
% OF RAISE 3%

END DATE 5/31/2025

ESCALATION PER YEAR

year	First date	Last date	Months	% of Contract
0	12/1/2024	5/31/2025	6	100.00%

The total escalation = 0.00%

PAYROLL RATES

FIRM NAME **Classen, White & Assor DATE** **11/11/24**
PRIME/SUPPLEMENT **Prime**
PTB-ITEM # **1**

ESCALATION FACTOR **0.00%**

Note: Rates should be capped on the AVG 1 tab as necessary

CLASSIFICATION	IDOT PAYROLL RATES ON FILE	CALCULATED RATE
Land Surveyor (S5)	\$57.40	\$57.40
Land Surveyor (S4)	\$45.70	\$45.70
Technician (T9)	\$40.30	\$40.30
Technician (T8)	\$32.00	\$32.00
Technician (T7)	\$26.50	\$26.50
Technician (T6)	\$0.00	\$0.00
Technician (T5)	\$0.00	\$0.00
Technician (T4)	\$20.00	\$20.00
Office Tech (OT4)	\$30.00	\$30.00
Administration (A3)	\$29.00	\$29.00



Direct Costs Check Sheet

Prime Consultant Name DuPage Water Commission	PTB Number	State Job Number(s)
<input checked="" type="checkbox"/> Prime <input type="checkbox"/> Supplement Date <u>11/11/24</u>		

Consultant
Claassen, White & Associates, P.C.

Item	Allowable	Utilize W.O. Only	Quantity J.S. Only	Contract Rate	Total
Per Diem (per GOVERNOR'S TRAVEL CONTROL BOARD)	Up to state rate maximum	<input type="checkbox"/>			
Lodging (per GOVERNOR'S TRAVEL CONTROL BOARD)	Actual cost (Up to state rate maximum)	<input type="checkbox"/>			
Lodging Taxes and Fees (per GOVERNOR'S TRAVEL CONTROL BOARD)	Actual cost	<input type="checkbox"/>			
Air Fare	Coach rate, actual cost, requires minimum two weeks' notice, with prior IDOT approval	<input type="checkbox"/>			
Vehicle Mileage (per GOVERNOR'S TRAVEL CONTROL BOARD)	Up to state rate maximum	<input type="checkbox"/>			
Vehicle Owned or Leased	\$32.50/half day (4 hours or less) or \$65/full day	<input type="checkbox"/>	20	\$65.00	\$1,300.00
Vehicle Rental	Actual cost (Up to \$55/day)	<input type="checkbox"/>			
Rental Vehicle Fuel	Actual cost (Submit supporting documentation)	<input type="checkbox"/>			
Tolls	Actual cost	<input type="checkbox"/>			
Parking	Actual cost	<input type="checkbox"/>			
Overtime	Premium portion (Submit supporting documentation)	<input type="checkbox"/>			
Shift Differential	Actual cost (Based on firm's policy)	<input type="checkbox"/>			
Overnight Delivery/Postage/Courier Service	Actual cost (Submit supporting documentation)	<input type="checkbox"/>			
Copies of Deliverables/Mylars (In-house)	Actual cost (Submit supporting documentation)	<input type="checkbox"/>			
Copies of Deliverables/Mylars (Outside)	Actual cost (Submit supporting documentation)	<input type="checkbox"/>			
Project Specific Insurance	Actual cost	<input type="checkbox"/>			
Monuments (Permanent)	Actual cost	<input type="checkbox"/>			
Photo Processing	Actual cost	<input type="checkbox"/>			
2-Way Radio (Survey or Phase III Only)	Actual cost	<input type="checkbox"/>			
Telephone Usage (Traffic System Monitoring Only)	Actual cost	<input type="checkbox"/>			

Scope of Services

Client DuPage Water Commission PTB/ Item IDOT Job No. CWA Work Order Location 1 Location 2 IDOT Project No. Consultant CWA Job Number Date	13 Metering Stations Claassen, White & Associates, P.C. November 11, 2024
Item 1 Quality Control / Quality Assurance 1.1 QA/QC Meetings 1.2 Checking Computations 1.3 Checking Plats 1.4 Checking Legal Descriptions 1.5 Checking Field Data Sub-total Quality Control / Quality Assurance	Man-hours Land Surveyor (S5) 7 Land Surveyor (S4) Land Surveyor (S1) Technician (T9) Technician (T8) Technician (T7) Technician (T6) Technician (T5) Technician (T4) Technician (T3) Technician (T2) Technician (T1) Office Technician (OT3) Office Technician (OT2) Office Technician (OT1) Administration (A3) Administration (A2) Administration (A1) Total 7



Resolution #: R-09-25

Account: 01-60-663100

Approvals: *Author / Manager / Finance / Admin*

D.P. RCB CAP PDM

REQUEST FOR BOARD ACTION

Date: 1/9/2025

Description: **A Resolution Approving and Ratifying Certain Work Authorization Orders Under Quick Response Contract QR-12/21 to Rossi Contractors, Inc.**

Agenda Section: Engineering & Construction

Originating Department: Pipeline & Remote Facilities

The Commission entered into certain agreements dated June 30, 2021, with John Neri Construction Co. Inc., Rossi Contractors Inc., and Benchmark Construction Co. Inc. for Quick Response construction work, as needed, through the issuance of Work Authorization Orders (Contract QR-12/21) and ending on June 30, 2025. Resolution No. R-09-25 would approve the following Work Authorization Orders under the Quick Response contracts.

Work Authorization Order No. 030 to Rossi Contractors, Inc.

Pipeline and Remote Facilities staff have identified nine (9) manhole frames & lids and cathodic protection handhole structures that require repairs. The repairs include breaking asphalt and/or concrete street surfaces/bases, excavating existing frames and adjustment rings, and resetting, replacing, or installing new adjustment rings, frames, or lids. Staff requested the QR contractors to provide an estimate for eight (8) structures for repairs with an option to include an additional one (1) structure, to be identified by Staff, for the potential of nine (9) structures to be repaired. The proposals are listed below:

Rossi Contractors, Inc.	\$112,020.00
John Neri Construction Co., Inc.	\$145,400.00
Benchmark Construction Co., Inc.	\$309,107.00

Staff believe the proposal of Rossi Contractors, Inc. is to be in the best interest of the Commission with a contingency of ten percent (10%) for unforeseen circumstance.

Recommended Motion:

To adopt Resolution No. R-09-25, WAO No. 030 for an estimated expense of \$123,200.00.

RESOLUTION NO. R-09-25

A RESOLUTION APPROVING CERTAIN WORK AUTHORIZATION ORDERS UNDER QUICK RESPONSE CONTRACT QR-12/21

WHEREAS, the DuPage Water Commission (the "Commission") entered into certain agreements dated June 30, 2021, with John Neri Construction Co., Inc., Rossi Contractors, Inc., and Benchmark Construction Co., Inc. for quick response construction work related to the Commission's Waterworks System (said being hereinafter collectively referred to as "Contract QR-12/21");

WHEREAS, Contract QR-1/21 is intended to allow the Commission to direct one or more or all the quick response contractors to perform quick response construction work, including without limitation construction, alteration, and repair related to the Commission's Waterworks System, as needed through the issuance of Work Authorization Orders; and

WHEREAS, the scope for quick response construction work could not have been reasonably foreseen at the time the contracts were signed;

NOW, THEREFORE, BE IT RESOLVED by the Board of Commissioners of the DuPage Water Commission as follows:

SECTION ONE: The foregoing recitals are by this reference incorporated herein and made a part hereof as findings of the Board of Commissioners of the DuPage Water Commission.

SECTION TWO: The work Authorization Orders attached hereto and by this reference incorporated herein and made a part hereof as Exhibit 1 shall be and hereby are approved and, if already issued, ratified because the Board of Commissioners of the DuPage Water Commission has determined, based upon the representations of staff, that the circumstances said to necessitate the work

Authorization Orders were not reasonably foreseeable at the time the contracts were signed, the Work Authorization Orders are in the best interest of the DuPage Water Commission and authorized by law.

SECTION THREE: This Resolution shall be in full force and effect from and after its adoption.

	Aye	Nay	Absent	Abstain
Bouckaert, D.				
Cuzzone, N.				
Fennell, J.				
VACANT	_____			
Novotny, D.				
Pruyn, J.				
Romano, K.				
Rush, K.				
Russo, D.				
Saverino, F.				
Suess, P.				
Van Vooren, D.				
Zay, J.				

ADOPTED THIS _____ DAY OF _____, 2025.

James F. Zay, Chairman

ATTEST:

Danna Mundall, Clerk

Board/Resolutions/2025/R-09-25.docx

EXHIBIT 1

Work Authorization Order No 030
And Rossi Contractors, Inc. Proposal 8327

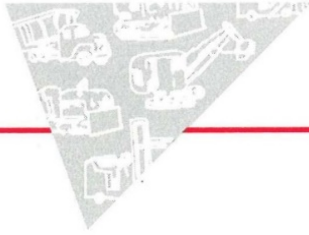

ROSSI CONTRACTORS, INC.

201 W. LAKE ST. • NORTHLAKE, IL 60164
773-287-7545 • FAX 708-562-1965

January 6, 2025

DuPage Water Commission
600 E. Butterfield Rd.
Elmhurst, IL 60126

**RE: DWC QR-12/21
2025 Frame & Lid Repairs
Proposal #8327**

To Whom It May Concern:

Rossi Contractors, Inc. is pleased to present this proposal for labor, equipment, and materials for the following work:

Scope: Repair 16 frames and lids to manhole/handhole structures, as noted by the DuPage Water Commission, with restoration to disturbed areas. DWC will supply frames, lids, and handholes as needed for repair.

Lump Sum Budget: \$112,020.00

Exclusions/Clarifications:

- This proposal is budgetary. Final cost to be determined following completion of work.
- Estimated traffic control, bond costs, and permit costs are included.
- Work to be completed during normal daytime hours.
- Work not described above is excluded.
- ****Please note that Rossi has already begun the permit process for Sites #1/2; the permits are readily available vs. the standard IDOT 8-week lead time.**

Respectfully submitted,

Taylor Heppeler

Taylor Heppeler
Project Manager
Rossi Contractors, Inc.

#	Asset	Village	Comments on Repairs	Estimated Cost
1	10104	Itasca	Replace frame and lid with new. Pavement removal to replace frame and lid. IDOT specifications	\$17,560.00
2	11141	Addison	Replace frame and lid with new. Pavement removal to replace frame and lid. IDOT specifications	\$17,560.00
3	10230	Downers Grove	Replace frame and lid with new if required. Pavement removal and new adjustment rings and concrete collar and match road material.	\$9,570.00
4	10166	Warrenville	Replace frame and lid with new if required. Pavement removal and new adjustment rings and concrete collar and match road material.	\$12,700.00
5	11064	Clarendon Hills	Replace frame and lid with new if required. Pavement removal and new adjustment rings and concrete collar and match road material.	\$9,530.00
6	10568	Naperville	Reset frame to grade. Pavement removal and new adjustment rings and concrete collar and match road material. May require oversized rings.	\$12,700.00
7	10520	Downers Grove	4' or 5' Diameter structure needs to be adjusted to grade with a 2' riser section and rings. Currently buried in parkway.	\$9,500.00
8	21685	Wheaton	Replace frame and lid with new if required. Pavement removal and new adjustment rings and concrete collar and match road material.	\$9,530.00
9	Unknown	TBD	Repair/install frame and lid in an asphalt or concrete paved area. Work requires breaking asphalt and/or concrete street base, excavation of existing frame and adjustment rings, resetting, replacing or installing new adjustment rings, frame and lid, restoration in compliance with the local authority having jurisdiction, of existing roadway pavement, curb/gutter, sidewalk and parkway disturb or damaged due to repair work.	\$13,370.00

WORK AUTHORIZATION ORDER

SHEET 1 OF 3

CONTRACT QR-12/21: QUICK RESPONSE CONTRACT

WORK AUTHORIZATION ORDER NO.: QR-12.030

LOCATION:

Various locations throughout Commission transmission and distribution system, see attached map book.

CONTRACTOR:

Rossi Contractors, Inc.

DESCRIPTION OF WORK:

In accordance with Rossi Contractor's proposal 8327 repairs include breaking asphalt and/or concrete street bases, excavating existing frames and adjustment rings, and resetting, replacing, or installing new adjustment rings, frames, or lids at 8 discrete locations plus an additional 1 location if deemed necessary and so directed by the Commission.

REASON FOR WORK:

Manhole lid and repairs are needed to maintain infrastructure and improve safe access to our pipeline facilities.

MINIMUM RESPONSE TIME:

N/A

COMMISSION-SUPPLIED MATERIALS, EQUIPMENT AND SUPPLIES TO BE INCORPORATED INTO THE WORK:

DWC will supply all frames and lids needed for the repairs, the contractor is to provide everything else.

THE WORK ORDERED PURSUANT TO THIS WORK AUTHORIZATION ORDER

IS IS NOT PRIORITY WORK

SUPPLEMENTARY NOTIFICATION OF POTENTIALLY HAZARDOUS CONDITIONS:

N/A

SUBMITTALS REQUESTED:

N/A

SUPPLEMENTARY CONTRACT SPECIFICATIONS AND DRAWINGS:

See attached.

DUPAGE WATER COMMISSION

By: _____
Signature of Authorized
Representative

DATE: _____

CONTRACTOR RECEIPT ACKNOWLEDGED AND DESIGNATION OF SAFETY REPRESENTATIVE:

By: _____ Safety Rep: _____
Signature of Authorized Name and 24-Hr Phone No.
Representative

DATE: _____



Resolution #: R-10-25

Account: 01-60-663200

Approvals: *Author / Manager / Finance / Admin*

D.P. RCB CAP PDM

REQUEST FOR BOARD ACTION

Date: 1/9/2025

Description: **A Resolution Approving and Ratifying Certain Work Authorization Orders Under Quick Response Contract QR-12/21 to Rossi Contractors, Inc.**

Agenda Section: Engineering & Construction

Originating Department: Pipeline & Remote Facilities

The Commission entered into certain agreements dated June 30, 2021, with John Neri Construction Co. Inc., Rossi Contractors Inc., and Benchmark Construction Co. Inc. for Quick Response construction work, as needed, through the issuance of Work Authorization Orders (Contract QR-12/21) and ending on June 30, 2025. Resolution No. R-10-25 would approve the following Work Authorization Orders under the Quick Response contracts.

Work Authorization Order No. 029 to Rossi Contractors, Inc.

Staff identified 4 discrete locations requiring the repair and modification of cathodic protection system of steel water mains. The modification work is in preparation for the feasibility study to provide adequate cathodic protection according to the Association for Materials Protection and Performance (AMPP) standards. The work will require installation of new coupon testing assemblies and high potential magnesium anodes, precast handholes, saw cutting of pavement, removal of sidewalk, and restoration of the disturbed areas to existing conditions in accordance with the requirements of the Authority Having Jurisdiction. Staff recently solicited cost estimates for this work from the three QR-12/21 contractors and the results are listed in the table below:

Rossi Contractors, Inc.	\$76,600.00
John Neri Construction Co., Inc.	\$79,600.00
Benchmark Construction Co., Inc.	\$261,931.00

The estimate of Rossi Contractors, Inc. was found to be in the best interest of the Commission. Approval of Resolution R-10-25 would approve Work Authorization Order Number 029 to Rossi Contractors, Inc. for the work necessary to install new galvanic anode beds at various locations.

The estimated cost of this work is expected to be \$91,920.00, which includes the estimated cost of construction as well as a 20% contingency to account only for field changes as deemed necessary by Commission staff.

Recommended Motion:

To adopt Resolution No. R-10-25.

RESOLUTION NO. R-10-25

A RESOLUTION APPROVING CERTAIN WORK AUTHORIZATION ORDERS UNDER QUICK RESPONSE CONTRACT QR-12/21, FOR CATHODIC PROTECTION

WHEREAS, the DuPage Water Commission (the "Commission") entered into certain agreements dated June 30, 2021, with John Neri Construction Co., Inc., Rossi Contractors, Inc., and Benchmark Construction Co., Inc. for quick response construction work related to the Commission's Waterworks System (said being hereinafter collectively referred to as "Contract QR-12/21");

WHEREAS, Contract QR-1/21 is intended to allow the Commission to direct one or more or all the quick response contractors to perform quick response construction work, including without limitation construction, alteration, and repair related to the Commission's Waterworks System, as needed through the issuance of Work Authorization Orders; and

WHEREAS, the scope for quick response construction work could not have been reasonably foreseen at the time the contracts were signed;

NOW, THEREFORE, BE IT RESOLVED by the Board of Commissioners of the DuPage Water Commission as follows:

SECTION ONE: The foregoing recitals are by this reference incorporated herein and made a part hereof as findings of the Board of Commissioners of the DuPage Water Commission.

SECTION TWO: The work Authorization Orders attached hereto and by this reference incorporated herein and made a part hereof as Exhibit 1 shall be and hereby are approved and, if already issued, ratified because the Board of Commissioners of the DuPage Water Commission has determined, based upon the representations of staff, that the circumstances said to necessitate the work

Authorization Orders were not reasonably foreseeable at the time the contracts were signed, the Work Authorization Orders are in the best interest of the DuPage Water Commission and authorized by law.

SECTION THREE: This Resolution shall be in full force and effect from and after its adoption.

	Aye	Nay	Absent	Abstain
Bouckaert, D.				
Cuzzone, N.				
Fennell, J.				
VACANT	_____			
Novotny, D.				
Pruyn, J.				
Romano, K.				
Rush, K.				
Russo, D.				
Saverino, F.				
Suess, P.				
Van Vooren, D.				
Zay, J.				

ADOPTED THIS _____ DAY OF _____, 2025.

James F. Zay, Chairman

ATTEST:

Danna Mundall, Clerk

Board/Resolutions/2025/R-10-25.docx

EXHIBIT 1

Work Authorization Order No 029
And Rossi Contractors, Inc. Proposal 8328

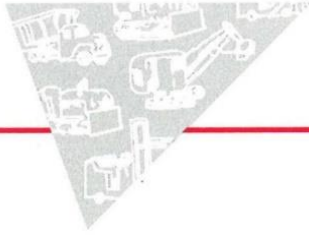

ROSSI CONTRACTORS, INC.

201 W. LAKE ST. • NORTHLAKE, IL 60164
773-287-7545 • FAX 708-562-1965

January 6, 2025

DuPage Water Commission
600 E. Butterfield Rd.
Elmhurst, IL 60126

**RE: DWC QR-12/21
2025 Cathodic Protection
Proposal #8328**

To Whom It May Concern:

Rossi Contractors, Inc. is pleased to present this proposal for labor, equipment, and materials for the following work:

Scope: Earthwork/excavation, handhole/anode installation, and restoration for DWC cathodic repairs at 4 sites as described on the following page.

Lump Sum Budget: \$76,600.00

Exclusions/Clarifications:

- This proposal is budgetary. Final cost to be determined following completion of work.
- Estimated traffic control, bond costs, and permit costs are included. Dedicated representatives for Safety and Quality Control are excluded, however, flaggers are included as needed.
- Unforeseen utility conflicts not identified by project plans are excluded.
- Work to be completed during normal daytime hours.
- Work not described above is excluded.

Respectfully submitted,



Taylor Heppeler
Project Manager
Rossi Contractors, Inc.

Site		Description of Work	DWC provided	Price
1	ComEd Corridor 250' south of Lake St. Addison	1)Procure all permits to accommodate work. 2)Excavate at approximate station 2+50 to the crown of pipe and provide excavation safety devices to allow DWC personnel access to exothermically weld wires onto the existing 16" Ductile Iron Pipe. 3)Install a precast handhole onsite at a location determined by owner. 4) Restore disturbed areas to existing conditions to the requirements of the Authority Having Jurisdiction (AHJ)	1 precast handhole	\$14,400.00
2	Southbound Highland Ave 200' south of Janata Blvd. Lombard	1)Procure all permits to accommodate work. 2)Full depth sawcut at station 28+37 of existing pavement meeting the requirements of the AHJ to accommodate a 3' deep trench to the parkway. 3) Replace frame and lid and deteriorated adjustment rings 4) Core a 2" hole into the existing vault and install 2" PVC conduit 4" into the vault and run through the trench line into handhole with an upward facing short sweep elbow. 5)Install a precast handhole onsite at a location determined by owner within the ROW limits. 6)Auger or Hydro-Excavate 1-12" diameter well 8' deep for Cathodic Protection Coupon within ROW limits in parkway (Backfilled with native material or clean black dirt). 7)Auger or Hydro-Excavate 3-12" diameter wells 15' deep for 3-48 lb. High Potential Magnesium Anodes ea. spaced 5' apart within ROW limits in parkway (Backfilled with native material or clean black dirt). Provide a 3' deep trench between wells for DWC staff to accommodate wire splicing. Exposed wires shall be encased in 3" PVC and fittings. 8)Restore disturbed areas to existing conditions to the requirements of the Authority Having Jurisdiction (AHJ)	1 precast handhole. 1 DWC frame and lid, 9-48 lb. magnesium sacrificial anodes and lead wires, 1 Cathodic protection coupon assembly and lead wire. 6-gauge HMWPE wire and splices.	\$20,700.00
3	Southbound Highland Ave 1000' north of Butterfield Rd. Lombard	1)Procure all permits to accommodate work. 2)Full depth sawcut at station 10+30 of existing pavement meeting the requirements of the AHJ to accommodate a 3' deep trench to the parkway/sidewalk. 3) Replace frame and lid and deteriorated adjustment rings 4) Core a 2" hole into the existing vault and install 2" PVC conduit 4" into the vault and run through the trench line into handhole with an upward facing short sweep elbow. 5)Install a precast handhole onsite at a location determined by owner within the ROW limits. 6)Auger or Hydro-Excavate 1-12" diameter well 8' deep for Cathodic Protection Coupon within ROW limits in parkway (Backfilled with native material or clean black dirt). 7)Auger or Hydro-Excavate 3-12" diameter wells 15' deep for 3-48 lb. High Potential Magnesium Anodes spaced 5' apart within ROW limits in parkway (Backfilled with native material or clean black dirt). Provide a 3' deep trench between wells for DWC staff to accommodate wire splicing. Exposed wires shall be encased in 3" PVC and fittings. 8)Restore disturbed areas to existing conditions to the requirements of the Authority Having Jurisdiction (AHJ)	1 precast handhole. 1 DWC frame and lid, 9-48 lb. magnesium sacrificial anodes and lead wires, 1 Cathodic protection coupon assembly and lead wire. 6-gauge HMWPE wire and splices.	\$18,200.00
4	Virginia St 100' east of Lacey in Downers Grove	1)Procure all permits to accommodate work. 2)Full depth sawcut of existing pavement meeting the requirements of the AHJ. 3)Excavate to the crown of pipe at approximate station 50+75 and provide excavation safety devices to allow DWC personnel access to exothermically weld wires onto the existing 36" Steel Water Main. 4) Trench and run 2" PVC conduit into handhole with an upward facing short sweep elbow into a placed precast handhole. Handhole shall be placed in the parkway ROW limits at a location determined by owner. 5)Auger or Hydro-Excavate 1-12" diameter well 8' deep for Cathodic Protection Coupon within ROW limits in parkway (Backfilled with native material or clean black dirt). 6)Auger or Hydro-Excavate 4-12" diameter wells 15' deep for 3-48 lb. High Potential Magnesium Anodes ea. spaced 5' apart within ROW limits in parkway (Backfilled with native material or clean black dirt). Provide a 3' deep trench between wells for DWC staff to accommodate wire splicing. Exposed wires shall be encased in 3" PVC and fittings. 7)Restore disturbed areas to existing conditions to the requirements of the Authority Having Jurisdiction (AHJ)	1 precast handhole. 16-48 lb. magnesium sacrificial anodes and lead wires, 1 Cathodic protection coupon assembly and lead wire. 6-gauge HMWPE wire and splices.	\$23,300.00

WORK AUTHORIZATION ORDER

SHEET 1 OF 3

CONTRACT QR-12/21: QUICK RESPONSE CONTRACT

WORK AUTHORIZATION ORDER NO.: QR-12.029

LOCATION:

Various locations throughout Commission transmission and distribution system, see attached map book.

CONTRACTOR:

Rossi Contractors, Inc.

DESCRIPTION OF WORK:

In accordance with Rossi Contractor's proposal 8328, modification works include installation of new coupon testing assemblies and high potential magnesium anodes, precast handholes, saw cutting of pavement, removal of sidewalk, and restoration of the disturbed areas to existing conditions in accordance with the requirements of the Authority Having Jurisdiction.

REASON FOR WORK:

The modification work is in preparation for the feasibility study to provide adequate cathodic protection according to the Association for Materials Protection and Performance (AMPP) standards.

MINIMUM RESPONSE TIME:

N/A

COMMISSION-SUPPLIED MATERIALS, EQUIPMENT AND SUPPLIES TO BE INCORPORATED INTO THE WORK:

DWC will supply all frames and lids needed for the repairs, the contractor is to provide everything else.

THE WORK ORDERED PURSUANT TO THIS WORK AUTHORIZATION ORDER

IS IS NOT PRIORITY WORK

SUPPLEMENTARY NOTIFICATION OF POTENTIALLY HAZARDOUS CONDITIONS:

N/A

SUBMITTALS REQUESTED:

N/A

SUPPLEMENTARY CONTRACT SPECIFICATIONS AND DRAWINGS:

See attached.

DuPAGE WATER COMMISSION

By: _____
Signature of Authorized
Representative

DATE: _____

CONTRACTOR RECEIPT ACKNOWLEDGED AND DESIGNATION OF SAFETY REPRESENTATIVE:

By: _____ Safety Rep: _____
Signature of Authorized Name and 24-Hr Phone No.
Representative

DATE: _____



Resolution #: R-11-25
Account: 01-80-852010

Approvals: *Author / Manager / Finance / Admin*
JL JML CAP PDM

REQUEST FOR BOARD ACTION

Date: 1/9/2025

Description: WaterLink (Phase III) Contract – Program Management (Initiation Only) and Book Road Bid Package Construction Engineering

Agenda Section: Engineering & Construction

Originating Department: Engineering

With construction of the WaterLink Project to begin in 2025, Commission staff recently advertised a Request for Qualifications (RFQ) to engineering firms for Phase III (construction engineering) services, with the goal of identifying those firms that are interested and qualified to provide construction engineering services over the six WaterLink bid packages and/or to serve in a Program Manager role. A total of six Statements of Qualifications (SOQ) were received from well-qualified firms and reviewed by commission staff. Two firms were then short-listed as potential candidates to serve as Program Manager and were invited to give a presentation to commission staff so that their qualifications and experience could be further explored. Upon review of all SOQs and participation in subsequent presentations, commission staff is recommending a contract with Burns & McDonnell Engineering Co., Inc. to provide Construction Engineering services on the “Book Road” bid package, as well as to serve as Program Manager throughout the WaterLink construction phase. The six firms that submitted SOQs can be seen below:

*Arcadis U.S., Inc./Christopher B. Burke Engineering, Ltd.
Bowman Consulting Group Ltd.
*Burns & McDonnell Engineering Company, Inc.
Jacobs Engineering Group Inc.
Stanley Consultants
TYLin/Greeley and Hansen Water Solutions

*Firms invited to present their qualifications/experience specific to the Program Manager role

Ultimately, the Burns & McDonnell team displayed a vast amount of experience in both Construction Engineering and Program Manager roles on WIFIA-funded projects. Additionally, they have exhibited a complement of available services that will be necessary during construction, including competent field staffing, web-based project communications, WIFIA compliance reporting, program management

software, etc. All of which are anticipated to work in concert to ensure that the WaterLink Project is constructed in a safe, efficient, and transparent manner.

Burns & McDonnell currently has an active Master Services Agreement (MSA) with the Commission, dated October 21, 2022, for professional engineering services in connection with such discrete projects as are delineated and described in Task Orders to be approved by the Commission. The proposed contract, attached as Exhibit A, will be formalized as Task Order No. 5 under the existing MSA once approved.

It should be noted that this Task Order includes construction engineering services for the full duration of the “Book Road” bid package” however, it only includes the *initiation* phase of the Program Manager services effort. During preliminary discussions with the Burns & McDonnell team, it was determined that it would be difficult to establish an accurate scope of services for the full Program Manager role prior to program initiation. For this reason, only the initiation phase is included in the current Task Order. Once the initiation phase is completed, a more fully-developed scope of services for the Program Manager role will be brought forward for Board consideration in twelve-month increments.

It is staff’s recommendation that Task Order No. 5 with Burns & McDonnell Engineering Company, Inc. be approved in the amount of \$3,613,698 and in the manner described in the attached Exhibit A to provide Construction Engineering Services on the “Book Road” bid package and for the initiation phase of the Program Manager services on the WaterLink Project.

Recommended Motion:

To approve Resolution No. R-11-25.

DuPAGE WATER COMMISSION

RESOLUTION NO. R-11-25

A RESOLUTION TO AUTHORIZE SCOPE OF SERVICES FOR TASK ORDER NO. 5 UNDER A MASTER SERVICES AGREEMENT WITH BURNS & MCDONNELL ENGINEERING, CO., INC.

WHEREAS, the Commission was formed and exists pursuant to the Water Commission Act of 1985, 70 ILCS 3720/0.01 et seq., and Division 135 of Article 11 of the Illinois Municipal Code, 65 ILCS 5/11-135-1 et seq., for the purpose of securing an adequate source and supply of water for its customers; and

WHEREAS, the Commission entered into a contract with Burns & McDonnell Engineering Co., Inc. (the "Consultant"), dated October 21, 2022, to provide, from time to time, professional engineering services in connection with the design and construction of extensions and improvements to the Waterworks System and other projects of the Commission (the "Master Contract"); and

WHEREAS, the Master Contract sets forth the terms and conditions pursuant to which the Commission will obtain from time to time, and the Consultant will provide from time to time, professional engineering services for such discrete projects as are delineated and described in Task Orders to be approved by the Commission and the Consultant; and

WHEREAS, the Consultant has developed the Scope of Services attached hereto and by this reference incorporated herein and made a part hereof as Exhibit A, which is approved and will be formalized into Task Order #5 under the existing MSA.

NOW, THEREFORE, BE IT RESOLVED by the Board of Commissioners of the DuPage Water Commission as follows:

SECTION ONE: The foregoing recitals are hereby incorporated herein and made a part hereof as findings of the Board of Commissioners of the DuPage Water Commission.

SECTION TWO: The Scope of Services attached hereto as Exhibit A shall be and hereby is approved and will be formalized as Task Order 5 under the existing MSA, and if already issued, ratified because the Board of Commissioners of the DuPage Water Commission has determined, based upon the representations of staff and consultant, that the circumstances said to necessitate the Task Orders were not reasonably foreseeable at the time the Master Contract was signed, the Task Orders are germane to the Master Contract as signed, and/or the Task Orders are in the best interest of the DuPage Water Commission and authorized by law.

SECTION THREE: This Resolution shall be in full force and effect from and after its adoption.

	Aye	Nay	Absent	Abstain
Bouckaert, D.				
Cuzzone, N.				
Fennell, J.				
VACANT	_____			
Novotny, D.				
Pruyn, J.				
Romano, K.				
Rush, K.				
Russo, D.				
Saverino, F.				
Suess, P.				
VanVooren, D.				
Zay, J.				

ADOPTED THIS _____ DAY OF _____, 2025.

James F. Zay, Chairman

ATTEST:

Danna Mundall, Clerk

DUPAGE WATER COMMISSION

WATERLINK PROGRAM INITIATION AND CONSTRUCTION ENGINEERING FOR BID PACKAGE 1 (BOOK RD) SCOPE OF SERVICES (Updated January 7, 2025)

Consultant: Burns & McDonnell Engineering Company, Inc.
 Commission: DuPage Water Commission
 Project: WaterLink Program
 Contract Period (assumed): Task Series 0000 – January 17 to April 30, 2025
 Task Series 3000 – January 17, 2025 to April 28, 2027

Contents

General	2
Basic Services	4
Task Series 0000 – WaterLink Initiation	5
Task 0010 – Initiation Phase Project Management	5
Task 0020 – Program Kickoff	5
Task 0030 – Project Definition and Constructability/Value Review.....	5
Task 0040 – Program Management Plan	6
Task 0050 – Program Management Office Mobilization	6
Task 0060 – Team Collaboration and Partnering	7
Task Series 1000 – WaterLink Programmatic Activities [RESERVED].....	8
Task Series 2000 – Construction Administration [RESERVED].....	8
Task Series 3000 – Construction Engineering for Bid Package 1 (Book Rd).....	8
Task 3010 – Project Management Services	8
Task 3020 – Pre-Construction Meeting	9
Task 3030 – Review Shop Drawings and Requests for Information (RFI)	9
Task 3040 – Review Contractor Pay Applications and Change Orders.....	10
Task 3050 – Provide Data for Program Dashboard	10
Task 3060 – Construction Layout	10
Task 3070 – GIS Data Collection	10
Task 3080 – Construction Observation.....	10
Task 3090 – Material Testing	11
Task 3100 – Project Closeout.....	11
Additional Services	11

Commission’s Responsibilities 13
Clarifications 14
End of Scope of Services 16

General

The DuPage Water Commission (Commission) is a unit of local government existing and operating under the State of Illinois Water Commission Act of 1985. The Commission is responsible for the financing, construction, acquisition, and operation of a water system to provide Lake Michigan water supply to municipal and private-utility customers in DuPage, Cook, and Will counties. The DuPage Water Commission currently provides water to 30 entities. In 2022, legislation was amended to permit the DuPage Water Commission to extend service to additional areas in Kendall and Kane counties. This legislation was the result of the 2021 selection of the DuPage Water Commission as the preferred source of Lake Michigan water to the municipalities of Montgomery, Oswego, and Yorkville, also known as the “WaterLink Communities”.

The Commission intends to provide Lake Michigan drinking water to the WaterLink Communities through a singular point of connection to the Commission’s existing 48-inch diameter transmission main at Book Road and 75th Street in Naperville via a transmission main and network of smaller diameter distribution mains. A total of seven delivery structures (three for Oswego, two for Montgomery and two for Yorkville) will be fed by approximately 32 miles of pipeline, ranging from 54” to 20” in diameter. Pipeline materials may consist of Prestressed Concrete Cylinder Pipe (PCCP), Steel Pipe and Ductile Iron Pipe. Construction will also include tunneling, river crossings, highway crossings, deep excavation, jack-and-bore, construction of remote-operated valves and impressed and passive cathodic protection services. Significant portions of the project will be within a ComEd right of way (ROW) and may be impacted by wetlands.

The design and construction of the WaterLink program will be managed by the Commission and funded by the WaterLink Communities. Funding sources will likely include local funds, Congressionally Directed Spending (CDS) funds, and Water Infrastructure Finance and Innovation Act (WIFIA) funds.

Other Consultants and Contractors. The Commission has retained a team of engineering firms consisting of Lockwood Andrews, and Neuman (LAN), Robinson Engineering, and Stanley Consultants (Design Engineering Consultant) to provide preliminary and final design engineering services for the WaterLink program. It is expected that the Design Engineering Consultant will provide engineering services during construction, including the review of submittals, shop drawings, requests for information (RFI), etc. The Commission has contracted separately for legal, financial advising, rate consulting, and public outreach strategy development services. It is anticipated that the Commission will retain the services of multiple other consultants (Construction Engineering Consultants) to provide construction engineering services for individual WaterLink program contracts. It is anticipated that the Commission will engage multiple contractors (Construction Contractors) through a competitive public bidding process to construct the individual contracts under the WaterLink program.

Program Elements. The construction phase will be split into separate bid packages, with approximately 6 bid packages associated with pipeline installation and the installation of meter stations as summarized below.

- Bid Package 1 (Book Rd): Approximately 16,300 linear feet of 54-inch diameter water transmission main
- Bid Package 2 (54" ComEd): Approximately 58,100 linear feet of 54-inch diameter water transmission main
- Bid Package 3 (FM – North): Approximately 20,400 linear feet of 20- to 24-inch diameter water transmission main
- Bid Package 4 (FM – South Branch): Approximately 47,000 linear feet of 36-inch diameter water transmission main
- Bid Package 5 (FM – Orchard to Y#1): Approximately 23,300 linear feet of 24-inch diameter water transmission main
- Bid Package 6 (Meter Stations): Seven (7) meter stations

Summary of Status. As of December 12, 2024, the Design Engineering Consultant has progressed the design of the WaterLink bid packages to approximately 90% completion. Bid Package 1 (Book Rd) is expected to be issued for bid in late February 2025 with the other bid packages following approximately every month from May to August 2025. WaterLink pipeline and meter station construction is currently scheduled to occur from July 2025 through October 2027, with commissioning completed by December 31, 2027. Lake Michigan water is scheduled to be delivered to the WaterLink communities as follows: Oswego/Yorkville by May 1, 2028 and Montgomery by May 1, 2030.

The Project. Burns & McDonnell Engineering Co., Inc. (Consultant) will act as the Commission's Construction Program Manager to provide staff resources to assist the Commission in the initiation of initiatives, activities, and tasks associated with the WaterLink program as defined in this Scope of Services. Additionally, the Commission has requested that Consultant provide construction engineering services for Bid Package 1 (Book Rd). Due to the nature of Commission needs over the term of this contract, certain work tasks, products or activities may change or extend this Scope of Services as mutually agreed upon by the Commission and Consultant.

Consultant will work collaboratively with the Commission and others under contract to the Commission to support implementation of the WaterLink program. Consultant will provide any authorized program management Services as an extension of the Commission's staff. In this limited agency role, it is the intent of the parties that Consultant shall not be at risk to the Commission for or assume any liability for the Services or Equipment provided by others under direct contract, purchase order, or otherwise employed by, or working directly or indirectly for the Commission. The Design Engineering Consultant has the sole responsibility for the design and Construction Contractors have the sole responsibility for construction of the WaterLink program. The Commission will look solely to the Design Engineering Consultant or Construction Contractors or other third-party for any deficiencies or defects in the work or work product. The Commission will provide a waiver for any claims or liabilities arising out of or related to any third-party work or work product. The Consultant will be acting as an agent and extension of Commission; review comments by Consultant will be provided as opinions for Commission's consideration, decision, and action. Consultant is not expected to validate or confirm the accuracy, adequacy,

completeness, or suitability of any third-party' work or work product. Should Consultant discover anything in the work product that causes Consultant to be concerned about the function, safety or suitability of the work or work product, Consultant will notify Commission; however, Consultant is not under a duty to discover all discrepancies, ambiguities, defects, or issues with any third-party work or work product. It is also understood that Consultant does not assume any responsibility for the accuracy and completeness of data and/or documents prepared by others, or for defects, omissions, departures from contractual requirements, or breach of performance of others working on the WaterLink program. It is further understood that Consultant will assist the Commission in its efforts to implement the WaterLink program, but that Consultant's services are not intended to, and cannot, eliminate all risk or guarantee an efficient or best value program and/or project.

Contract Renewal. Absent a major change in program scope, and predicated on continued satisfactory performance of Consultant, the Agreement will continue to be extended by additional Task Orders or Amendments based on mutual agreement regarding scope of services, staffing, and financial terms for each subsequent extension. Determination of the specific tasks necessary for each Task Order or Amendment will be agreed to by the Commission and Consultant prior to the beginning of each extension, subject to approval by the Commission's Governing Authorities.

Services described under Task Series 0000 – Program Initiation herein are expected to be provided from January 17 to April 30, 2025. Services described under Task Series 3000 – Construction Engineering for Bid Package 1 (Book Rd) are expected to be provided for the duration of the Bid Package 1 (Book Rd) contract (currently expected to be April 28, 2025 to April 28, 2027), subject to qualifications and clarifications regarding the project schedule. It is expected that an additional Task Order or Amendment will be mutually agreed to and executed in approximately April 2025 for the provision of services under Task Series 1000 – WaterLink Programmatic Activities and Task Series 2000 – Construction Administration for the period of May 1, 2025 to April 30, 2026 or later. Future Task Orders or Amendments for services beyond April 30, 2026 are expected.

Additional Services. It is understood that due to the unknown and changing nature of needs within the Commission over the term of this Agreement, that the types of Consultant services necessary to support activities of the WaterLink program may be changed, modified, or extended beyond the areas defined in Basic Services. Only major tasks have been captured in Basic Services. It is envisioned that over the course of the program, the Commission may require support on other initiatives and tasks. At the discretion of the Commission, and during the completion of the professional services defined in this Agreement, Consultant may be requested to provide additional Commission-authorized services under a future Task Order or Amendment to this Agreement.

Basic Services

The Basic Services to be provided by Consultant may include those services described below and organized under the following Task Series:

TASK SERIES 0000 – WaterLink Initiation

TASK SERIES 1000 – WaterLink Programmatic Activities [RESERVED]

TASK SERIES 2000 – Construction Administration [RESERVED]

TASK SERIES 3000 – Construction Engineering for Bid Package 1 (Book Rd)

Task Series 0000 – WaterLink Initiation

The Consultant will provide program initiation services as follows. It is anticipated that activity will occur on Task Series 0000 from January 17 to April 30, 2025.

Task 0010 – Initiation Phase Project Management

Consultant will provide project management services to administer its efforts under this task series, including the following.

- A. Prepare a scope, budget, schedule, and agreement for Consultant’s subconsultants involved in the Project. Conduct meetings as required to prepare subconsultant agreements; review services, work products, and deliverables; and to execute defined scope of work. Provide administration of subconsultant agreements including review of services, work products, and deliverables; subconsultant invoices; and schedule maintenance.
- B. Prepare and issue monthly invoices for services rendered with supporting cost backup in accordance with the payment application requirements defined in this Agreement.

Task 0020 – Program Kickoff

The Consultant will work collaboratively with the Commission to initiate the WaterLink program including the following tasks.

- A. Provide Commission with formal Request for Information (RFI) confirming items needed to review. It is anticipated that at a minimum, the RFI will include: 1) current version of the WaterLink program project list; 2) any available technical reports/conceptual designs for WaterLink program projects; 3) current WaterLink program budget and backup for project cost estimates completed to date; 4) current detailed schedule; 5) contracts for services (e.g., design engineering, geotechnical, survey, public outreach, etc.) being provided under the WaterLink program; 6) invoices paid to date.
- B. Kick-off meeting: Prepare for and conduct an kick-off meeting with the Commission to formally introduce key team members, establish lines of communication, confirm the status of WaterLink program activities, the plan for initiation phase workshops, and verify that Commission’s objectives have been clearly identified. It is anticipated that Consultant team members located in the Chicago area will participate in person with remote participation by other team members.

Task 0030 – Project Definition and Constructability/Value Review

Following receipt of the information requested above, Consultant will prepare for a workshop with Commission and the Design Engineering Consultant. It is anticipated that the Design Engineering Consultant will summarize the definition, scope, limits, status, schedule, cost, and risk items for the currently identified WaterLink program projects. Anticipated support related to engineering services during construction will be discussed. It is anticipated that Consultant team members located in the Chicago area will participate in person with remote participation by other team members.

Following the workshop, the Consultant will review the current drawings and specifications to gain a general understanding of the current definition of the WaterLink program projects. It is not expected that the Consultant will review the cost opinions prepared by the Design Consultant. Following its review, Consultant will prepare a summary of comments related to potential opportunities identified for the following items. Comments will be provided for the Commission's consideration, decision, and action.

- A. Program controls items (schedule or cost control) that could be incorporated into the upcoming construction contracts.
- B. Changes to the drawings related to constructability or value.

Task 0040 – Program Management Plan

Following receipt and review of information requested above, Consultant will prepare for and conduct an in-person workshop with Commission to review key objectives and processes for WaterLink program functions. Based on discussion during the workshop, WaterLink program charter and objectives, strategies, and critical success factors to support the charter will be established. Preliminary protocols for the consistent delivery of projects under the WaterLink program will begin to be developed into a preliminary Program Management Plan (PgMP). The following aspects are expected to be tailored to the unique requirements of the WaterLink program:

- Program foundation
- Program governance
- Program controls
- Performance monitoring and reporting
- Document controls
- Agency/Stakeholder collaboration
- Public engagement and communications
- Funding administration and compliance tracking
- Construction administration
- Utility coordination

Consultant will conduct an in-person workshop with Commission to review the draft PgMP. Working Version 1.0 of the PgMP will be drafted based on discussion during the workshop. The PgMP is expected to be a living document that will be refined and adjusted on a regular basis. Formal, comprehensive updates will occur on a basis not more frequent than annually.

Task 0050 – Program Management Office Mobilization

Consultant will begin to establish the integrated program management organization (PMO) and the supporting processes, systems, and tools, baseline schedules and budgets, and reporting and administrative processes required for the WaterLink program. It is anticipated that the activities described below will be initiated to make substantial progress towards the establishment of such items, and that further refinement will occur as part of Task Series 1000.

- A. Facilitate the definition of key Project Management Information System (PMIS) functions needed for the WaterLink program.

- B. Procure and deploy PMIS tools to support the overall program. It is anticipated that the following tools will be used:
- i. Procore (cost and document management)
 - ii. Primavera P6 (scheduling)
 - iii. Power BI (cost and schedule dashboard reporting)
 - iv. ArcGIS Online (field progress reporting)
- C. Develop preliminary baseline program schedules and budgets for individual WaterLink contracts and the overall program.
- D. Develop preliminary web-based dashboard reports in Power BI for the communication of program cost and schedule information to program stakeholders. Up to three (3) dashboard reports will be developed.
- E. Develop up to three (3) preliminary web-based dashboards in the Commission’s ArcGIS Online environment to display GIS data related to the WaterLink program.
- F. Develop up to three (3) preliminary mobile applications for field personnel to collect GIS-related data.
- G. Develop template specifications for inclusion in upcoming construction contractors describing document, cost, and schedule management requirements of Construction Contractors.
- H. Prepare a summary of reports to be produced for various WaterLink program stakeholders, and develop standard report templates, which are anticipated to include the following:
- i. A monthly program status report and dashboard summary describing program progress summary, costs, cash flow, schedule summary, and issues or changes with the potential to impact overall program cost or schedule.
 - ii. An annual program progress summary for distribution to elected officials and the public that describes overall program progress, schedule, highlights, and accomplishments.
- I. Identify potential locations for temporary office space for use by Construction Engineering Consultants during the WaterLink program.

Note that a budget will be included in the forthcoming Task Order or Amendments for services after April 30, 2025 for licensing of program management software.

Task 0060 – Team Collaboration and Partnering

Consultant will support the Commission’s efforts to establish, develop, and maintain a collaborative environment for stakeholders involved in the WaterLink program as follows:

- A. Support the Commission’s review of proposals and scopes of services developed by Construction Engineering Consultants. Provide comments for the Commission’s consideration, decision, and action.

- B. Host one (1) virtual meeting with Consultant’s Partnering Facilitator and the Commission to review key concerns, risks, and opportunities unique to the WaterLink program, introduce the partnering process and develop a focused, specific agenda for the Partnering Session.
- C. Conduct one (1) in-person half-day to full-day Partnering Session with the Commission and the Commission’s Construction Engineering Consultants to review the WaterLink program charter and objectives, strategies, and critical success factors.

Task Series 1000 – WaterLink Programmatic Activities [RESERVED]

RESERVED FOR FUTURE TASK ORDER OR AMENDMENT

Task Series 2000 – Construction Administration [RESERVED]

RESERVED FOR FUTURE TASK ORDER OR AMENDMENT

Task Series 3000 – Construction Engineering for Bid Package 1 (Book Rd)

Consultant will provide construction engineering for Bid Package 1 (Book Road), hereafter referred to as “the Project” under this Task Series 3000. Services anticipated to be provided are described below. It is anticipated that activity will occur on Task Series 3000 from January 17, 2025 to April 28, 2027.

Task 3010 – Project Management Services

Consultant will work with the Program Management Office (PMO) and Commission to provide the necessary monitoring and reporting for the Project status and progress. The Consultant’s Construction Manager will be the primary liaison with the PMO and the Commission and lead an integrated team of construction/engineering staff and a material testing subconsultant. Services anticipated to be provided include:

- A. Meetings – Consultant will attend in-person meetings as follows:
 - i. Monthly WaterLink Program status meetings with the PMO and Commission.
 - ii. Weekly meetings with the PMO, Commission, and other Construction Engineering Consultants to discuss overall construction issues related to the WaterLink program.
 - iii. Weekly construction progress meetings with the PMO, Commission, and Construction Contractor regarding the Project.
- B. Project Status Updates – Consultant will provide the PMO and Commission with weekly progress reports providing updates on the work completed that week and projected for the following week on the Project.
- C. Monthly Invoicing, Reporting and Documentation – Consultant will provide project administration for services completed for this Project. Prepare and issue monthly invoices for services rendered with supporting cost backup and documentation in accordance with the payment procedures defined in this Agreement. Furnish to PMO and Commission one report each month containing a status summary with monthly invoices. Key activities, initiatives, and items requiring Commission action, approval, and/or concurrence will be documented.

- D. Project Schedules – Consultant will review the preliminary project schedule submitted by the Construction Contractor for the pre-construction meeting. Consultant will collaborate with the PMO to obtain their comments on the preliminary schedule as well. Review comments will be returned to the Construction Contractor. This schedule will be reviewed monthly to identify potential areas of concern and discuss recovery plans. The Construction Contractor will be required to provide two-week look-ahead schedules for each weekly construction progress meeting.
- E. Data Management – Consultant will utilize Procore for data management for the Project including meeting minutes, RFIs, shop drawings, schedules, O&M manuals, construction documents, change orders, pay applications, weekly/daily reports, etc.
- F. WIFIA Loan Documentation – Consultant will assist the PMO with information for the Project to support the preparation and submittal of required documentation associated with project initiation, project reporting and project closeout. These efforts will include:
- Provide information for quarterly WIFIA construction progress reports such as project status, percent complete and costs incurred.
 - Maintain AIS documentation and assist with AIS audits as needed.
 - Perform quarterly project-site Davis-Bacon interviews and complete interview form.
 - Confirm WIFIA signage is visible on sight.
 - Participate in meetings with the WIFIA team.
 - Prepare quarterly apprenticeship reporting reports.
- G. Subconsultant Coordination: Prepare scope, budget, schedule, and agreement for Consultant’s subconsultants. Conduct meetings as required to prepare subconsultant agreements; review professional services, work products, and deliverables; and to execute defined scope of work. Provide administration of subconsultant agreements including review of services, work products, and deliverables; subconsultant invoices; and schedule maintenance.

Task 3020 – Pre-Construction Meeting

Consultant will initiate and lead a preconstruction meeting for the Project. The Construction Contractor will be expected to present a list of proposed subcontracts, emergency contacts, and a proposed construction schedule at the meeting. Consultant will communicate meeting requirements to the Construction Contractor when issuing the Notice of Award and Notice to Proceed to give them time to prepare. All of the meeting documents will be uploaded to Procore and distributed via email with the meeting notes. Other attendees will include the PMO and Commission as well as other stakeholders identified for the Project.

Task 3030 – Review Shop Drawings and Requests for Information (RFI)

Consultant will log, review and distribute responses to shop drawings and RFIs for the Project using Procore. All shop drawings, with the exception of complex ones, will be responded to within seven calendar days of receipt from the Construction Contractor. Complex shop drawings will be returned within fourteen calendar days of receipt. We recognize that the Design Engineering

Consultant will have a contract with the Commission to consult on shop drawings and/or RFIs on an as-requested basis.

Task 3040 – Review Contractor Pay Applications and Change Orders

Consultant will review pay applications prepared and submitted by the Construction Contractor to confirm that the quantities requested for payment are in alignment with the quantities that have been agreed to between the Construction Contractor and the Consultant's field team. Once pay applications have been deemed acceptable, Consultant will submit the pay application to the Commission along with a letter of recommendation to initiate the request for payment for the Commission to process. Consultant will also review proposed change orders from the Construction Contractor. Each Potential Change Order will be evaluated for overall impact on the project budget. Potential Change Orders will also be evaluated to establish the merit, if any, of the Potential Change Order itself. Potential Change Orders that are determined to be valid will be submitted to the Commission along with a letter of recommendation from the Consultant.

Task 3050 – Provide Data for Program Dashboard

Consultant will provide information to the PMO on a regular basis to update programmatic websites and/or dashboards with Project specific information.

Task 3060 – Construction Layout

The Commission intends to retain the Design Engineering Consultant to provide construction layout for the Project. Consultant will invite the Design Engineering Consultant to the pre-construction meeting to facilitate a discussion with the Construction Contractor as to their desires for construction layout such as length, offsets, etc. As construction progresses, Consultant will verify that the Construction Contractor is requesting that the Design Engineering Consultant perform the construction layout.

Task 3070 – GIS Data Collection

The Construction Contractor is responsible for using GPS units to collect GPS coordinates of the water main and appurtenances as they are being installed. They will also be responsible for uploading this data to the Commission's GIS. The Consultant will be responsible for verifying that this work is being completed.

Task 3080 – Construction Observation

Under Basic Services, Consultant will provide a team consisting of a part-time construction manager and a full-time resident engineer to observe and monitor the work performed by the Construction Contractor. The Consultant's team will be responsible for completing daily reports to document work activities. The Consultant team will track pay item quantities installed each day and at the completion of that day, agree to the quantities installed with the Construction Contractor.

Consultant's budget for Basic Services includes each team member providing construction observation for a maximum of 40 hours per week. The construction manager is budgeted for 27 weeks (135 days) while the resident engineer is budgeted for 100 weeks (500 days). Any time above these budgeted amounts or overtime exceeding 40 hours per week will be tracked on a time and material basis. The overall Project schedule is assumed to be based on the project duration indicated in the schedule included in the meeting minutes from the Commission's November 21,

2024 meeting (April 28, 2025 to April 28, 2027). Additional time will be required to provide construction observation for a Project duration that exceeds the assumed Project schedule. As the budget is expended, funds under Additional Services will be used, or a Task Order or Amendment will be prepared for processing by the Commission, to add additional budget to cover the remainder of the Project.

After the budget included in this task order for Consultant's construction manager is expended, it is anticipated that Consultant's construction manager will continue to provide construction observation services for Bid Package 1 (Book Rd) and/or other construction contracts. Such services will be described in forthcoming Task Orders or Amendments as part of Task Series 2000.

Additional resources beyond a part-time construction manager and full-time resident engineer may be required to observe and monitor work performed by the Construction Contractor, based on the Construction Contractor's schedule, the number of crews working, and their activities. Time has been budgeted under Additional Services to cover periods of increased work activity. One staff level individual has been budgeted full-time for 18 months and one assistant level individual has been budgeted full-time for 12 months. The budget has been developed assuming the provision of construction observation services for a maximum of 40 hours per week. Any time above these budgeted amounts or overtime exceeding 40 hours per week will be tracked on a time and material basis. As the budget is expended, Task Orders or Amendments will be prepared for processing by the Commission, to add additional budget to cover the remainder of the Project.

Task 3090 – Material Testing

Consultant has included an allowance for material testing for portland cement concrete, hot-mix asphalt and compaction of backfill materials. An allowance is proposed because specific pay items and plan quantities are not known at this time. Based on the material testing requirements in the project specifications, Consultant will schedule material testing accordingly. We will track each time our subconsultant is called out to perform material testing and track their budget on a monthly basis. If the allowance is projected to be exceeded, Consultant will prepare a Task Order or Amendment for consideration and approval by the Commission. All material testing documentation will be uploaded to Procore and any deficiencies will be immediately communicated to the Construction Contractor, PMO and Commission.

Task 3100 – Project Closeout

Consultant will initiate and lead a punch list walk through for the Project with representatives from the PMO, Commission and the Construction Contractor. The punch list will be shared with all parties and once the Construction Contractor has confirmed that all items have been completed, the Consultant will perform a follow-up site walk to confirm that all items are done. As a part of the project closeout, the Consultant will provide requested information to the Design Engineering Consultant for their completion of the project record drawings.

Additional Services

Under this Agreement, the Commission may request the Consultant to provide a wide range of staff resources to supplement and support Commission staff in utility operations, management and implementation of the Commission's WaterLink program. Any work requested by the Commission that is not specifically stated in one of the Basic Services listed above and able to be completed

within the contract budget will be classified as Additional Services. Additional Services will not be performed, nor is the Consultant approved to proceed, unless the Commission provides written authorization to Consultant that includes the scope of work for each Additional Service to be performed and a maximum billing limit for compensation that has been mutually agreed upon. Additional Services may include, but not limited to:

- A. Additional and unforeseen WaterLink program related assignments that are agreed by the Commission and Consultant. This includes providing Staff resources beyond those defined in the organizational chart and staffing plan, including subject matter experts.
- B. Changes in the general scope, extent, design, or character of the WaterLink program, including:
 - i. Changes in size or complexity.
 - ii. Commission's program schedule, design, or character of projects; and
 - iii. Method of financing or availability of funding.
- C. Appearances at public hearings or before special boards beyond those defined under Basic Services.
- D. Develop and implement an independent value-engineering program to help designs of individual projects prepared by the Design Engineering Consultant meet budget limitations.
- E. Development of detailed independent opinions of probable construction cost (OPCC) to validate OPCCs prepared by others.
- F. Regulatory and compliance reporting.
- G. Field subsurface investigations, geotechnical investigations, environmental site assessments, or easement or right-of-way selection, preparation, appraisals, negotiation, or acquisition work.
- H. Assist Commission with the development and implementation of training programs or workshops with Design Engineering Consultant or Construction Contractors to review project management, engineering, or resident project representative services items. This could include the creation of training presentation materials to capture current WaterLink program and Commission internal processes; specific technical, construction, or administrative topics; or offering opportunities for specialized training or certifications.
- I. Assist with implementation of a Computerized Maintenance Management System (CMMS).
- J. Working with contractors and constituents to address deficiencies identified during a correction period inspection program (Warranty inspections).
- K. Perform transfer of files and document/data migration to/from currently utilized file management systems and/or the Commission's document storage systems.
- L. The review of and implementation of changes to existing Commission standard documents.

- M. Verification and/or updates of record documents received from the Design Engineering Consultant and/or Construction Contractors during construction.
- N. Identification of potential third-party funding sources for WaterLink program or preparation of application materials and supporting documentation to request third-party funding.
- O. Financial consulting services to assist the Commission with its capital improvement planning, long-term financial modeling, and cash flow management associated with the WaterLink program. This may include development and analyses of alternative capital funding plans, financial capabilities analyses, cost of service studies, utility rate analyses, or other financial-related evaluations.

Commission's Responsibilities

Commission will furnish the following items, as required by the Basic Scope of Services, and not at the expense of the Consultant:

- A. Designate a contact person to act on behalf of the Commission with respect to management of this Consultant contract.
- B. Furnish, as requested by the Consultant for performance of services the following:
 - i. All Commission's standard documents and procedures pertaining to WaterLink program activity;
 - ii. Timely written notice of potential program or project schedule delays caused by funding or other Commission constraints;
 - iii. Data and information applicable to the WaterLink program prepared by or resulting from services of others including contracts, planning, design and construction documents;
 - iv. Commission shall be responsible for, and Consultant may rely upon without independent verification, the accuracy and completeness of all reports, data, and other information furnished pursuant to this paragraph. Consultant may use such reports, data, and information in performing or furnishing services under this Agreement.
- C. Provide access to and make all provisions for Consultant to enter upon public and private property as required for Consultant to perform services under this Agreement.
- D. Provide, as may be required for WaterLink program:
 - i. Accounting, bond and financial advisory, independent and insurance counseling services;
 - ii. Such legal services as Commission may require or Consultant may reasonably request regarding legal issues pertaining to WaterLink program, including any that may be raised by professional service providers or Construction Contractors;
 - iii. Such auditing services as Commission may require to ascertain how or for what purpose service providers or Construction Contractors have used the moneys paid on account for their Contract Price; and

- iv. Funding and payment of any required geotechnical investigation, materials testing, and environmental assessment services;
 - v. Bear all costs incidental to compliance with the requirements of the Commission's Responsibilities.
- E. Provide the services of at least one Commission employee who has the right of entry to and knowledge of existing Commission facilities. Site visits will be required on multiple occasions over the course of the Project.
- F. Operate all existing equipment, valves, or other systems necessary for operations, functional or performance testing.
- G. Commission shall be responsible for, and Consultant may rely upon, the accuracy and completeness of all requirements, programs, instructions, reports, data, and other information furnished by or through Commission to Consultant pursuant to this Agreement. Consultant may use such requirements, reports, data, and information in performing or furnishing services under this Agreement without independently verifying the accuracy, completeness, or currentness of such information.
- H. Advise Consultant of the identity and scope of services of any independent consultants, designers, contractors, construction managers, or other third parties employed by Commission to perform or furnish services in regard to the Program or a Specific Project, and define and set forth in writing the duties, responsibilities, and limitations of authority of such other parties and the relation thereof to the duties, responsibilities, and authority of Consultant.
- I. Public advertisement and procurement of WaterLink program projects.
- J. Payment of regulatory permitting fees.
- K. Fees associated with project, document, or data management systems.

Clarifications

The following clarifications and assumptions apply to this scope of services:

- A. It is anticipated that all documents and deliverables submitted will be electronically distributed. The costs for paper copies are not included.
- B. Estimates, schedules, forecasts, and projections, if any, prepared by Consultant are opinions based on Consultant's experience, qualifications, and judgment as a professional. Since Consultant has no control over weather, cost and availability of labor, cost and availability of material and equipment, cost of fuel or other utilities, labor productivity, Construction Contractor's procedures and methods, unavoidable delays, Construction Contractor's methods of determining prices, economic conditions, government regulations and laws (including the interpretation thereof), competitive bidding or market conditions, and other factors affecting such estimates or projections, Consultant

does not guarantee that actual rates, costs, quantities, performance, schedules, etc., will not vary significantly from estimates and projections prepared by Consultant.

- C. When it becomes necessary for Consultant to review, inspect, or observe the work or work product performed or prepared Commission or by others working on behalf of Commission, Commission and Consultant agree that such review, inspection, or observation is solely for the purpose of understanding the project or related information and work product.
- D. Consultant is not reviewing the work or work product of others to scrutinize, evaluate, assess, revise or change the design or any means or methods of fabrication, assembly, installation or construction expressed in the work product and Consultant is not being engaged to serve as the design professional in connection with this project or work product; all of which shall remain sole responsibility of the preparer (whether Commission or its subcontractors or suppliers).
- E. Consultant's review is solely to provide the Commission with opinions and/or considerations that the Commission may or may not want to consider. No action or implementation regarding any opinion, recommendation, or observation expressed should be implemented without the involvement of the third-party design engineer.
- F. If Consultant provides services during the design phase of a Specific Project, Consultant shall not supervise, direct, or have control over a Design Professional's work, nor shall Consultant have authority over or responsibility for the design, and/or be the engineer of record, architect of record or in responsible charge, or for any failure of a Design Professional to perform its services pursuant to its Contract Documents or any failure to comply with Laws and Regulations applicable to a Design Professional's furnishing and performing the work.
- G. If Consultant provides services during the construction phase of a Specific Project, Consultant's sole responsibility will be to observe and report the execution of the Specific Project. Consultant shall not supervise, direct, or have control over a Construction Contractor's work, nor shall Consultant have authority over or responsibility for the means, methods, techniques, sequences, or procedures of construction selected or used by a Construction Contractor, for safety or security at the Site, for safety precautions and programs incident to a Construction Contractor's work in progress, or for any failure of a Construction Contractor to comply with Laws and Regulations applicable to a Construction Contractor's furnishing and performing the work. Commission shall advise Commission's Design Professionals and Construction Contractors regarding Consultant's authority.
- H. Consultant neither guarantees the performance of any Design Professional, Contractor, or third party, nor assumes responsibility for any Design Professional's, Contractor's, or third party's failure to furnish and perform the work in accordance with the Contract Documents. Consultant does not guarantee or warrant the budgets, schedules, or performance of or the work, work product, or deliverables of any of Design Professionals, Contractors, or the performance or actions of any third-parties relating to the Project or the Work.
- I. Consultant shall not be responsible for the acts or omissions of any Design Professional, Contractor, third party, or of any of a Design Professional's or Contractor's subcontractors,

suppliers, agents, or employees or any other persons at a Site (except Consultant's own employees and the Program Subcontractors) or otherwise furnishing or performing any of a Design Professional's or Contractor's work; or for any decision made on interpretations or clarifications of the Contract Documents given by Commission to a Design Professional or Contractor without consultation and advice of Consultant.

- J. Commission and Commission's Design Professionals, Contractors, and other third parties shall remain completely and solely responsible for means, methods, techniques, sequences, procedures, and the protection and safety of their personnel and work, and for those employees and subcontractors under which they have care, custody, or control. Under all circumstances, Commission's Contractor(s) will be directing the physical work and will be responsible for overall safety of the Project Site. In addition to following its own safety program, the Consultant will comply with the applicable Contractor's safety plan as is applicable to Consultant's services.
- K. Consultant shall not be responsible for, whether or not related to any Site visit: (i) construction means, methods, techniques, sequences, procedures, or safety precautions and programs in connection with work related to the Consultant's services; (ii) the failure of any of Commission's other Contractors, Design Professionals, or consultants or their respective employees, subcontractors, vendors, or other project participants, not under contract to Consultant, to fulfill contractual responsibilities to Commission or to comply with federal, state, or local laws, regulations, and codes; or (iii) procuring permits, certificates, and licenses required for any construction. Consultant shall not have the authority to direct, control or stop the work of Commission's Contractors, Design Professionals, or consultants or their respective employees, subcontractors, agents, or vendors.
- L. As part of Consultant's services, Consultant may bring, utilize, and develop Consultant's licensed or otherwise owned proprietary management systems (including, but not limited to, OneTouch PM™), and other tools and know-how in the performance of the services undertaken. Any new or additional know-how or intellectual property that may be developed or derived by Consultant for the improvement of the delivery of program management services shall remain the solely owned and exclusive property of Consultant. Documents in the form of reports or data developed by Consultant in support of the Commission's Project(s) and provided to Commission, and original information provided by or through Commission to Consultant in support of a Project, shall be the property of the Commission.
- M. In other contracts entered into by the Commission for other work related to the Consultant's services, the Commission's other contractors and consultants shall be required to provide waivers of subrogation in favor of the Commission and Consultant for damage or liability covered by any of the Commission's other contractor's or consultant's policies of insurance and to name Consultant as an additional insured on those policies of insurance and as a beneficiary of any indemnity, in the same manner, and to the same extent, as the Commission.

End of Scope of Services

Fee Summary

Project Name: WaterLink Program Initiation
 Client: DuPage Water Commission

Task No.	Task Description	Total Hours	Labor	Expenses	Total Fee
Task 0010	Initiation Phase Project Management	152	\$ 33,272.00	\$ -	\$ 33,272.00
Task 0020	Program Kickoff	74	\$ 16,708.00	\$ -	\$ 16,708.00
Task 0030	Project Definition and Constructability/Value Review	384	\$ 112,392.00	\$ -	\$ 112,392.00
Task 0040	Program Management Plan	898	\$ 183,364.00	\$ 17,600.00	\$ 200,964.00
Task 0050	Program Management Office Mobilization	1,144	\$ 182,112.00	\$ -	\$ 182,112.00
Task 0060	Team Collaboration and Partnering	60	\$ 18,288.00	\$ 33,000.00	\$ 51,288.00
Total		2,712	\$ 546,136.00	\$ 50,600.00	\$ 596,736.00

Task 0000 services to be provided on a reimburseable basis per billing rate schedule.

Fee Summary

Project Name: Construction Engineering for Book Rd
 Client: DuPage Water Commission

Task No.	Task Description	Total Hours	Labor	Expenses	Total Fee
3010	Project Management Services	480	\$ 125,568.00	\$ -	\$ 125,568.00
3020	Pre-Construction Meeting	16	\$ 4,824.00	\$ -	\$ 4,824.00
3030	Review Shop Drawings and Requests for Information (Included in 3080)	-	\$ -	\$ -	\$ -
3040	Review Contractor Pay Applications and Change Orders (Included in 3080)	-	\$ -	\$ -	\$ -
3050	Provide Data for Program Dashboard (Included in 3080)	-	\$ -	\$ -	\$ -
3060	Construction Layout (Included in 3080)	-	\$ -	\$ -	\$ -
3070	GIS Data Collection (Included in 3080)	-	\$ -	\$ -	\$ -
3080	Construction Observation	5,080	\$ 1,518,480.00	\$ 45,705.00	\$ 1,564,185.00
3090	Material Testing	-	\$ -	\$ 33,000.00	\$ 33,000.00
3100	Project Closeout	320	\$ 96,480.00	\$ -	\$ 96,480.00
Total	Basic Services	5,896	\$ 1,745,352.00	\$ 78,705.00	\$ 1,824,057.00
--	Additional Services	5,440	\$ 1,147,200.00	\$ 45,705.00	\$ 1,192,905.00
Total	Basic Services + Additional Services	11,336	\$ 2,892,552.00	\$ 124,410.00	\$ 3,016,962.00

Task 3000 services to be provided on a reimburseable basis per billing rate schedule.



Resolution #: R-12-25

Account: 01-60-663700 \$48,867

Approvals: *Author / Manager / Finance / Admin*

D.P. RCB CAP PDM

REQUEST FOR BOARD ACTION

Date: 1/9/2025

Description: **A Resolution Authorizing the General Manager to Purchase Frame and Lids from a Sole Source Manufacturer at a Cost Not-to-Exceed \$48,867.**

Agenda Section: Engineering & Construction

Originating Department: Pipeline & Remote Facilities

The Commission maintains an inventory of spare frames and lids for use as replacements in the event that those existing in service have failed beyond simple repair and require full replacement. The current in-stock inventory has reached levels that require replenishment. These custom-made frames and lids are embossed with the "DuPage Water Commission" name on the lid to distinguish them from others, and cast in existing molds made especially for this purpose which are retained by the sole-source manufacturer.

Since the sole manufacturer of the Frames and Lids utilized within the Commission's system does not maintain an inventory of these custom-made frame and lids within their manufacturing facilities, staff recommends stocking an in-house inventory to avoid excessive delays when performing emergency repairs and to allow these units to be installed immediately as needed.

Staff therefore recommend approval of Resolution No. R-12-25 to authorize the General Manager to purchase Frames and Lids from the sole source manufacturer, Neenah Foundry Co., at not-to-exceed cost of \$48,867.

Recommended Motion:

To approve Resolution No. R-12-25.

DuPAGE WATER COMMISSION

RESOLUTION NO. R-12-25

A RESOLUTION AUTHORIZING THE GENERAL MANAGER TO PURCHASE CUSTOM CAST FRAMES AND LIDS FROM NEENAH FOUNDRY COMPANY

WHEREAS, pursuant to Article VIII, Section 4 of the Commission's By-Laws, and as required by State Statute, the Commission solicited a proposal to Furnish and Deliver Custom Cast Frames and Lids; and

WHEREAS, Neenah Foundry Co., is the Sole Source Provider of Custom Cast Frames and Lids which are compatible with the Commission's existing water main system; and

WHEREAS, the Commission desires to purchase Custom Cast Frames and Lids; and

WHEREAS, based upon representations made by staff, the Board of Commissioners of the DuPage Water Commission has determined that it is in the best interest of the Commission to authorize the General Manager to purchase custom cast frames and lids from Neenah Foundry Company;

NOW, THEREFORE, BE IT RESOLVED by the Board of Commissioners of the DuPage Water Commission as follows:

SECTION ONE: The foregoing recitals are hereby incorporated herein and made a part hereof as findings of the Board of Commissioners of the DuPage Water Commission.

SECTION TWO The DuPage Water Commission hereby authorizes the purchase of Custom Cast Frames and Lids from Neenah Foundry Company, a sole source provider, for the price set forth in Its Proposal, but not to exceed \$48,867.

SECTION THREE: This Resolution shall be in full force and effect from and after its adoption.

	Aye	Nay	Absent	Abstain
Bouckaert, D.				
Cuzzone, N.				
Fennell, J.				
VACANT	_____			
Novotny, D.				
Pruyn, J.				
Romano, K.				
Rush, K.				
Russo, D.				
Saverino, F.				
Suess, P.				
Van Vooren, D.				
Zay, J.				

ADOPTED THIS _____ DAY OF _____, 2025.

James F. Zay, Chairman

ATTEST:

Danna Mundall, Clerk
Board/Resolutions/2025/R-12-25docx

QUOTATION

Q00180564



2121 Brooks Ave
Neenah, Wisconsin 54956

PHONE: 920-729-3840 | FAX:
alex.kreul@groupnei.com

Attn:
Phone:
Mobile Phone:
Email:

Date: Dec 12, 2024
Job Name:
Job Location:
Expiration Date: Dec 19, 2024
Bid Date:

We are pleased to submit the following quotation in accordance with your request.

Line	Quantity	Catalog	Description	Sales Price	Total Price
1	11 SETS	6660-JH	R-6660-JH DWC Water HATCH FRAME--TYPE-N--REGULAR SEAT--GI CLASS 35B--W/OUT BOLT PADS IN CORNERS HATCH SOLID LID--TYPE-C--REGULAR SEAT--GI CLASS 35B--23-1/2 X 23-1/2 X 3/4	\$1,637.00	\$18,007.00
2	20 SETS	1755-F2	R-1755-F2 DWC Water FRAME--TYPE-A--MACHINED SEAT--GI CLASS 35B--7/8IN.ON 34-1/4 BC,AA29-1/8,B1-3/8,LTRD.'NEENAH FOUNDRY CO'--'AASHTO M306 CLASS 35B', 'MADE IN USA' SOLID PLATEN LD--TYPE-K--MACHINED SEAT--GI CLASS 35B--@ 180 DEGREES, 28-3/4 X 1-3/8--'WATER' 1 IN. LETTERS PLAIN INNER LID--TYPE-N--MACHINED SEAT--GI CLASS 35B--26-3/4 X 1--"LINE UP WITH LOCK BAR TO CLOSE" LOCK BAR--TYPE-N--GI CLASS 35B--28X2X1 DRILL&TAP 1/2" THRU & COUNTERBORE 1/2" DEEP W/17/32"	\$1,543.00	\$30,860.00
Quotation Comments: Price includes (1) truckload shipment					
TOTAL ESTIMATED WEIGHT: 10,594 lbs (Excluding Skids)				TOTAL QUOTATION VALUE:	<u>\$48,867.00</u>
				(Freight Included)	

TERMS & CONDITIONS

Neenah Foundry Terms & Conditions apply and are available upon request. Castings furnished unpainted. Quantities are approximate, changes could alter unit prices. Estimated Shipping & Handling based on above quantities shipping in one complete shipment. Any order submitted pursuant to this quotation shall not result in a contract until it is accepted and acknowledged in writing by Neenah Foundry Company (SELLER).

Notwithstanding any contrary provision in the incorporated Terms and Conditions, this quote shall expire after 7 days from the date of issuance. All orders are subject to review of buyer's credit status. Standard terms for qualified customers are Net 30 Days. Prices do not include tax. If tax exempt, please provide a sales tax exemption certificate at time of order or any applicable tax will be charged.

QUOTATION
Q00180564



https://groupnei.com/App_Uploads/PageContent/salesTC_133640825765439047.pdf

FOB Origin Pre-pay & Allow

NEENAH FOUNDRY COMPANY

BY _____

Alex Kreul
Sales Representative



Resolution #: R-13-25

Account: 01-80-852010

Approvals: *Author / Manager / Finance / Admin*

JL JML CAP PDM

REQUEST FOR BOARD ACTION

Date: 1/9/2025

Description: A Resolution Authorizing the Pre-purchase of three 48" valves for the WaterLink Project.

Agenda Section: Engineering & Construction

Originating Department: Engineering

In order to proceed with the WaterLink connection to the existing Commission transmission mains, three new valves will need to be installed. Two will be installed on the existing 48" transmission main along 75th street, on either side of the proposed connection, with the third to be installed on the new pipeline just south of the connection. The placement of these three valves is standard practice to create an isolation zone for the connection and will also create an improved ability to supply the WaterLink communities with water if a shutdown of the existing Commission pipeline to the east or west of the connection is required in the future.

The WaterLink connection is one of many components associated with the "Book Road" bid package, the first of six WaterLink bid packages to be awarded in 2025. This bid package is scheduled to be awarded in spring 2025, with the connection to be made during a low-flow period in the fall/winter months. Due to lengthy lead times for the purchase of the critical valves, staff recommends pre-purchasing and storing the valves until the contractor is ready to install them, to ensure that this work can take place during the ideal timeframe.

In accordance with Commission Purchasing Procedures, staff solicited proposals from three vendors for these valves, the results of which are listed below:

Manufacturer	Cost
Val-Matic Valve and Manufacturing Corp.	\$176,126.00
DeZURIK, Inc.	\$266,828.00
J&S Valve, Inc.	No Proposal Received

The timing of the solicitation resulted in proposals being received on the same day that Board packet paperwork submittals were required, and detailed review of the full submittals is currently being performed by DWC staff and the Phase II Engineering team to verify compliance with the required

specifications. At this time, staff is seeking authority to purchase the valves from the low-bidder following the full review of the submitted documents to ensure specification compliance.

Staff is therefore requesting approval of Resolution No. R-13-25 to authorize the General Manager to purchase three, 48" butterfly valves from Val-Matic Valve and Manufacturing Corp., at an estimated cost of \$176,126.00. This action does not include installation services, which will be completed during the WaterLink construction phase.

Recommended Motion:

To approve Resolution No. R-13-25.

DuPAGE WATER COMMISSION

RESOLUTION NO. R-13-25

**A RESOLUTION AUTHORIZING THE PRE-PURCHASE OF
THREE VALVES FOR THE WATERLINK CONSTRUCTION PROJECT FROM VAL-MATIC**

WHEREAS, pursuant to Article VIII, Section 4 of the Commission's By-Laws, and as required by State Statute, the Commission solicited proposals to furnish butterfly valves; and

WHEREAS, the Commission desires to pre-purchase three (3), forty-eight-inch (48") butterfly valves to facilitate the WaterLink connection to the existing Commission distribution network; and

WHEREAS, the designated valves are considered critical infrastructure; and

WHEREAS, it is staff's determination that time is of the essence and expediting the delivery of these valves is paramount: and

WHEREAS, two proposals were received, and

WHEREAS, based upon representations made by staff, the Board of Commissioners of the DuPage Water Commission has determined that the proposal of Val-Matic Valve and Manufacturing Corp., is most favorable to the interest of the Commission;

NOW, THEREFORE, BE IT RESOLVED by the Board of Commissioners of the DuPage Water Commission as follows:

SECTION ONE: The foregoing recitals are hereby incorporated herein and made a part hereof as findings of the Board of Commissioners of the DuPage Water Commission.

SECTION TWO: The DuPage Water Commission hereby authorizes the purchase of three (3) forty-eight-inch butterfly valves from Val-Matic Valve and Manufacturing Corp., for the price set forth in the Proposal, \$176,126.

SECTION THREE: This Resolution shall be in full force and effect from and after its adoption.

	Aye	Nay	Absent	Abstain
Bouckaert, D.				
Cuzzone, N.				
Fennell, J.				
VACANT	_____			
Novotny, D.				
Pruyn, J.				
Romano, K.				
Rush, K.				
Russo, D.				
Saverino, F.				
Suess, P.				
Van Vooren, D.				
Zay, J.				

ADOPTED THIS _____ DAY OF _____, 2025.

James F. Zay, Chairman

ATTEST:

Danna Mundall, Clerk

Board/Resolutions/2025/R-13-25docx



905 RIVERSIDE DRIVE • ELMHURST, IL 60126
 PHONE (630) 941-7600 • FAX (630) 941-8042
 www.valmatic.com • e-mail: valves@valmatic.com

BID PROPOSAL# A010725-1

Date: 1/07/25

To: DuPage Water Commission

Attn: Jeff Loster, PE, Engineering Manager

Job: WaterLink Extension Contract TW6-S1

Dear Mr. Loster,

Val-Matic® is pleased to offer the following.

Quantity	Size	Model & Description	Net Unit Price
1	48"	2448/2J02CXDX – AIS Compliant AWWA C504 250B* Flanged Butterfly valve w/125# flange drilling, Ductile iron body and disc, 17-4ph SS stub shafts, EPDM seat on disc, 316SS body seat ring, 18' centerline to centerline sealed carbon steel extended bonnet, submerged service traveling nut actuator w/stainless steel operating nut, stainless steel interior and exterior valve/bonnet/gear bolting, holiday free fusion bonded epoxy interior/exterior valve coating, 2-part epoxy exterior actuator coating	\$60,708.00
1	48"	2448/2J02CXDX – AIS Compliant AWWA C504 250B* Flanged Butterfly valve w/125# flange drilling, Ductile iron body and disc, 17-4ph SS stub shafts, EPDM seat on disc, 316SS body seat ring, 12'-6" centerline to centerline sealed carbon steel extended bonnet, submerged service traveling nut actuator w/stainless steel operating nut, stainless steel interior and exterior valve/bonnet/gear bolting, holiday free fusion bonded epoxy interior/exterior valve coating, 2-part epoxy exterior actuator coating	\$58,566.00
1	48"	2448/2J02CXDX – AIS Compliant AWWA C504 250B* Flanged Butterfly valve w/125# flange drilling, Ductile iron body and disc, 17-4ph SS stub shafts, EPDM seat on disc, 316SS body seat ring, 8'-3" centerline to centerline sealed carbon steel extended bonnet, submerged service traveling nut actuator w/stainless steel operating nut, stainless steel interior and exterior valve/bonnet/gear bolting, holiday free fusion bonded epoxy interior/exterior valve coating, 2-part epoxy exterior actuator coating	\$56,852.00
TOTAL F.O.B. FACTORY NET LOT PRICE			\$176,126.00

***Material deviation from spec.**

250B rated valves are being proposed based on spec. section 2.03.E.1 that calls for a 250psi transient pressure. Our 150B BFV's only carry a 200psi max surge pressure allowance. Our 150B 2000 series and 250B 2400 series valves are dimensionally the same. 17-4ph SS stub shafts are required to achieve the 250B rating instead of the 316SS shaft material called out in spec. section 2.03.D.3

- Notes:
1. Any deviation from this quotation can result in a change of price and availability for the items listed herein.
 2. Start-up and/or field services are included for one technician up to 5 days total.
 3. Factory witness testing less travel expenses is included and will be performed at our Addison, IL facility
 4. Standard Operation, Installation, and Maintenance manuals included.
 5. 5 year extended standard warranty from the date of shipment included.
 6. Products quoted comply with American Iron and Steel (AIS) requirements

WQA We do hereby certify compliance of all of our product lines for lead free drinking water systems per
NSF 61 NSF/ANSI 372/Annex G, California AB 1953 requirements.

Pricing: Valid 90 days and based on quantities and models shown.

Terms: **100% Net 30 days. Liquidated damages and/or retention are not allowed.**

All sales are subject to the Val-Matic Valve & Manufacturing Corp. (Val-Matic), Terms of Sale effective on receipt of the purchase order, which are incorporated in full by this reference. The Terms of Sale are available at <http://www.valmatic.com/terms.html>, and can be provided to the purchaser upon request. Val-Matic limits acceptance to the Terms of Sale, and objects to any other additional or different terms in the purchase order or acceptance.

Freight: F.O.B. factory with full freight allowed

Shipment: Approximately 36-38 weeks after receipt of approved drawings/purchase order.

Delivery is based on current material availability and is subject to prior sales.

Val-Matic® thanks you for this opportunity. Feel free to contact us if we may be of further service.

Prepared by,



Quote No. A010725-1

Page 2 of 3

Aaron Kielar

Central Regional Sales Manager
Val-Matic Valve & Mfg. Corp.

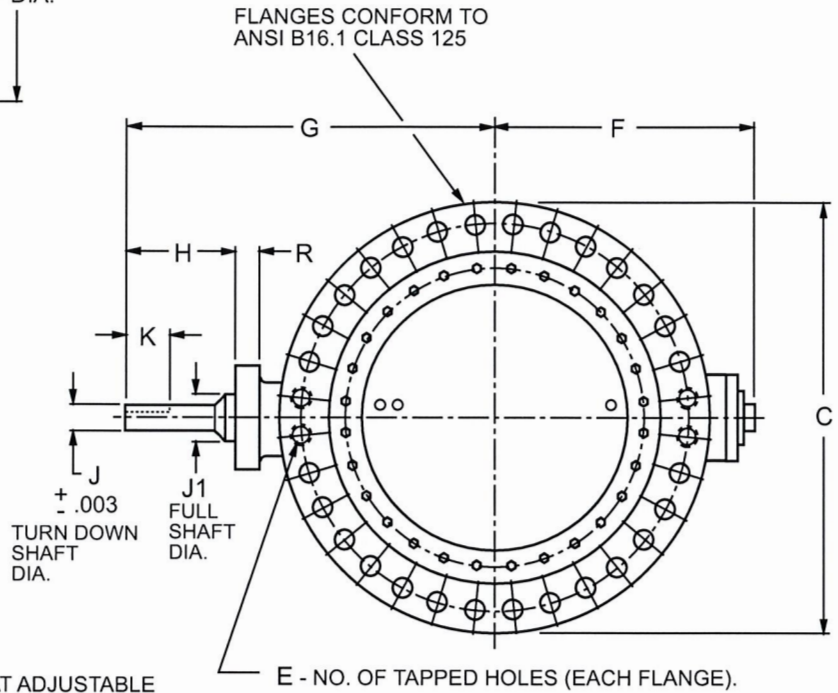
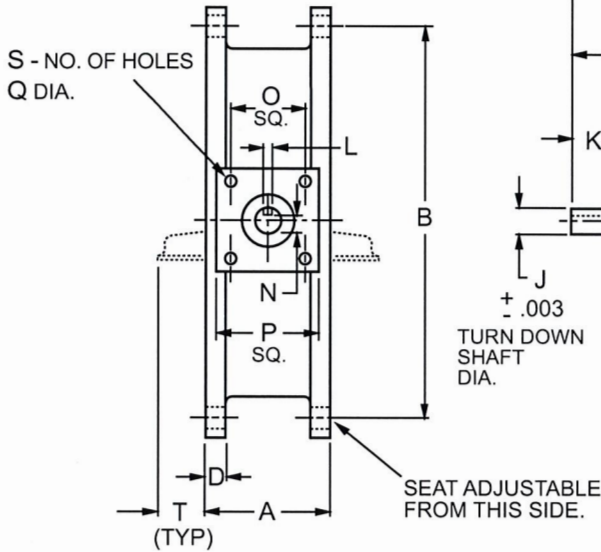
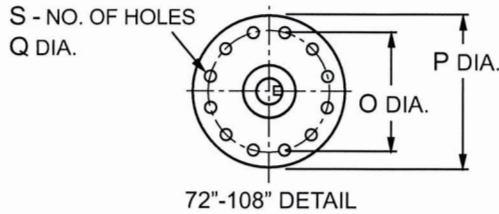

COLD WORKING PRESSURE 250 PSI (250B)

CLASS 125 LB. DUCTILE IRON FLANGE DIMENSIONS, INCHES

VALVE SIZE	AWWA C504 CLASS	A	B	C	D	NO. OF BOLTS	E Qty.	E Tap	E Deep	F	G	H	J	J1	K	L	N	O	P	Q	R	S	T	SHPG WT. lb.
30	250B	12.00	36.00	38.75	2.12	28	4	1 1/4-7	2.00	27.38	30.38	6.38	3.750 ±.003	3.75	4.44	.875	3.261	8.485	10.50	1.25	2.25	4	8.88	1710
36	250B	12.00	42.75	46.00	2.38	32	4	1 1/2-6	2.38	29.50	33.55	6.81	3.750 ±.003	4.50	4.44	.875	3.261	8.485	10.50	1.25	2.25	4	11.88	2470
42	250B	12.00	49.50	53.00	2.62	36	4	1 1/2-6	2.50	35.25	36.88	6.12	5.000 ±.005	5.00	4.75	1.25	4.296	8.485	10.50	1.25	2.25	4	14.75	4020
48	250B	15.00	56.00	59.50	2.75	44	4	1 1/2-6	2.50	39.31	44.12	9.12	5.750 ±.008	5.75	6.75	1.50	4.900	11.844	15.00	1.63	2.50	4	16.25	6420
54	250B	15.00	62.75	66.25	3.00	44	8	1 3/4-5	2.63	44.25	48.06	9.12	6.750 ±.008	6.75	6.75	1.75	5.760	11.844	15.00	1.63	2.50	4	19.25	8500
60	250B	15.00	69.25	73.00	3.12	52	8	1 3/4-5	2.63	48.25	51.94	9.12	6.750 ±.003	7.25	6.75	1.75	5.760	11.844	15.00	1.63	2.50	4	22.25	12100
66	250B	18.00	76.00	80.00	3.38	52	8	1 3/4-5	2.63	53.31	58.25	9.12	6.750 ±.003	7.75	6.75	1.75	5.760	11.844	15.00	1.63	2.50	4	23.69	14050
72	250B	18.00	82.50	86.50	3.50	60	8	1 3/4-5	2.38	59.00	62.75	10.75	8.000 ±.005	8.50	8.75	2.00	6.873	23.00	26.25	1.38	2.50	8	26.69	15200
84	250B	24.00	95.50	99.75	3.88	64	8	2-4 1/2	3.88	71.25	72.63	10.75	8.000 ±.008	10.00	8.75	2.00	6.873	23.00	26.25	1.38	2.50	8	29.63	25000
96	250B	26.00	108.50	113.25	5.13	68	8	2 1/4-4 1/2	3.25	79.38	88.06	21.75	10.000 ±.008	11.50	19.88	2.50	8.591	23.74	28.00	1.53	3.25	8	34.75	34500

SEE DRAWING SS-1993 AND SS-2039 FOR INSTALLATION AND TESTING.
SEE DRAWING VM-2030-M FOR STANDARD 250B MATERIALS AND CONSTRUCTION.

Revised 9-26-11

250B / 125 LB. DUCTILE IRON FLANGED BUTTERFLY VALVE WITH BARE STEM

DATE 10-29-07

VAL-MATIC® VALVE AND MANUFACTURING CORP.

DRWG. NO.
VM-2430/BS

BUTTERFLY VALVE

30"-72" SERIES 2000

MATERIALS OF CONSTRUCTION

PART NO.	PART NAME	STANDARD MATERIAL	OPTIONAL MATERIAL
1	BODY (CLASS 150B) BODY (CLASS 250B)	CAST IRON, ASTM A126, CLASS B DUCTILE IRON, ASTM A536, GRADE 65-45-12	DUCTILE IRON, ASTM A536, GRADE 65-45-12
2	BODY SEAT	STAINLESS STEEL ASTM A276, T316	WELDED NICKEL (OVERLAID ON BODY)
3	DISC	DUCTILE IRON, ASTM A536, GRADE 65-45-12	-
4	SHAFT (CLASS 150B) SHAFT (CLASS 250B)	STAINLESS STEEL ASTM A276, T304 STAINLESS STEEL ASTM A564, T630, H1150	STAINLESS STEEL ASTM A276, T316
5	SLEEVE BEARING	PTFE LINED, FIBERGLASS BACKED	-
6	RESILIENT SEAT	BUNA-N	PEROXIDE-CURED EPDM, EPDM, FKM
7	SEAT RETAINING RING	STAINLESS STEEL ASTM A743, GRADE CF8M	-
8	LOCKING CAP SCREWS	STAINLESS STEEL ASTM F593, T316 WITH NYLON PELLETT	-
9	TAPER PIN	STAINLESS STEEL ASTM A582, T416	-
10	TAPER PIN O-RING	EPDM	FKM
11	TAPER PIN NUT	STAINLESS STEEL ASTM F594, T316	-
12	TAPER PIN WASHER	STAINLESS STEEL ASTM A276, T316	-
13	PACKING, V-TYPE	BUNA-N	EPDM, FKM
14	KEY	CARBON STEEL	-
15	THRUST BEARING CAP	BRONZE PER ASTM B763	-
16	CAP SCREWS	STAINLESS STEEL ASTM A276, T316	-
17	THRUST BEARING STUD	BRONZE PER ASTM B763	-
18	THRUST PLATE	CAST IRON, ASTM A126, CLASS B	-
19	THRUST PLATE BOLTS	CARBON STEEL (ZINC PLATED)	STAINLESS STEEL, T316
20	THRUST PLATE GASKET	COMPRESSED NON-ASBESTOS FIBER	-
21	LOCK CAP	CAST IRON ASTM A126, CLASS B	-
22	LOCK CAP BOLTS	CARBON STEEL (ZINC PLATED)	STAINLESS STEEL, T316
23	LOCK CAP GASKET	COMPRESSED NON-ASBESTOS FIBER	-
24	BODY O-RING	RESILIENT, ASTM D2000	-

Revised: 9/26/23

MATERIALS OF CONSTRUCTION

DATE: 6-7-99

VALMATIC[®]

VALVE AND MANUFACTURING CORP.

DRWG. NO.

VM-2030-M

Valve Interior + Exterior

FUSION BONDED EPOXY (FBE) COATING

General Description:

Fusion Bonded Epoxy is a one-part, heat cured, thermosetting epoxy coating that is applied as a dry powder to the sandblasted surface of a pre-heated valve and then fused and cured in a high-temperature oven. The result is a durable coating with exceptional abrasion and chemical resistance ideally suited for valves in water and wastewater applications.

Advantages of FBE:

1. The coating is applied in accordance with AWWA Standard C550 "Protective Epoxy Coatings for Valves and Hydrants" and certified by to the requirements of ANSI/ NSF Standard 61 - "Drinking Water System Components - Health Effects" for coating valves and fittings.
2. FBE coatings are applied in an automated one-part process so that the mixing, surface preparation, and multiple-coat problems associated with liquid paints are eliminated.
3. The electrostatic application process for FBE provides a smooth, even coating thickness with no runs, sags, or thin spots common with applying liquid paints.
4. FBE coatings are durable and provide twice the impact strength of liquid epoxies. The surface provides high abrasion resistance and has become a standard seating material for resilient gate and check valves.
5. FBE has a long-term performance history in water and sewage environments including salt water, slurries, methane and hydrogen sulfide exposure.

Application Process:

1. FBE is applied in an automated manufacturing process in accordance with the coating manufacturers' procedures and industry standards to assure consistency and high quality.
2. The valve is cleaned, sandblasted, and preheated in an oven.
3. An electrical charge is applied to the body and the powder is deposited over the surfaces of the valve to the specified thickness.
4. The epoxy is post cured in an oven to cure specifications and allowed to air cool to room temperature.
5. The final surface is visually and electrically (when specified) tested to verify thickness and that it is holiday free.

Typical Performance Characteristics:

1. Color:	Blue	
2. Thickness	12-20 mils 16 mils min.	1 Coat
3. Gloss at 60 deg:	60-80 units	Din 67 530
4. Impact Resistance	>5 Joule (44 in-lb)	Din 30 677-2
5. Elongation:	>5%	Din 30 671
6. Hardness:	>100	Din 53 153
7. Water Immersion:	No visible change	90C, 672 Hours
8. Salt Spray Test:	>3000 hours	Din 53167
9. Adhesion:	16 Mpa (2320 psi)	7 days, 90C EN 24 624

Revised 2-15-17

FUSION BONDED EPOXY (FBE) COATING

DATE 7-17-02

VAL-MATIC®

VALVE AND MANUFACTURING CORP.

DRWG. NO.

SS-1847

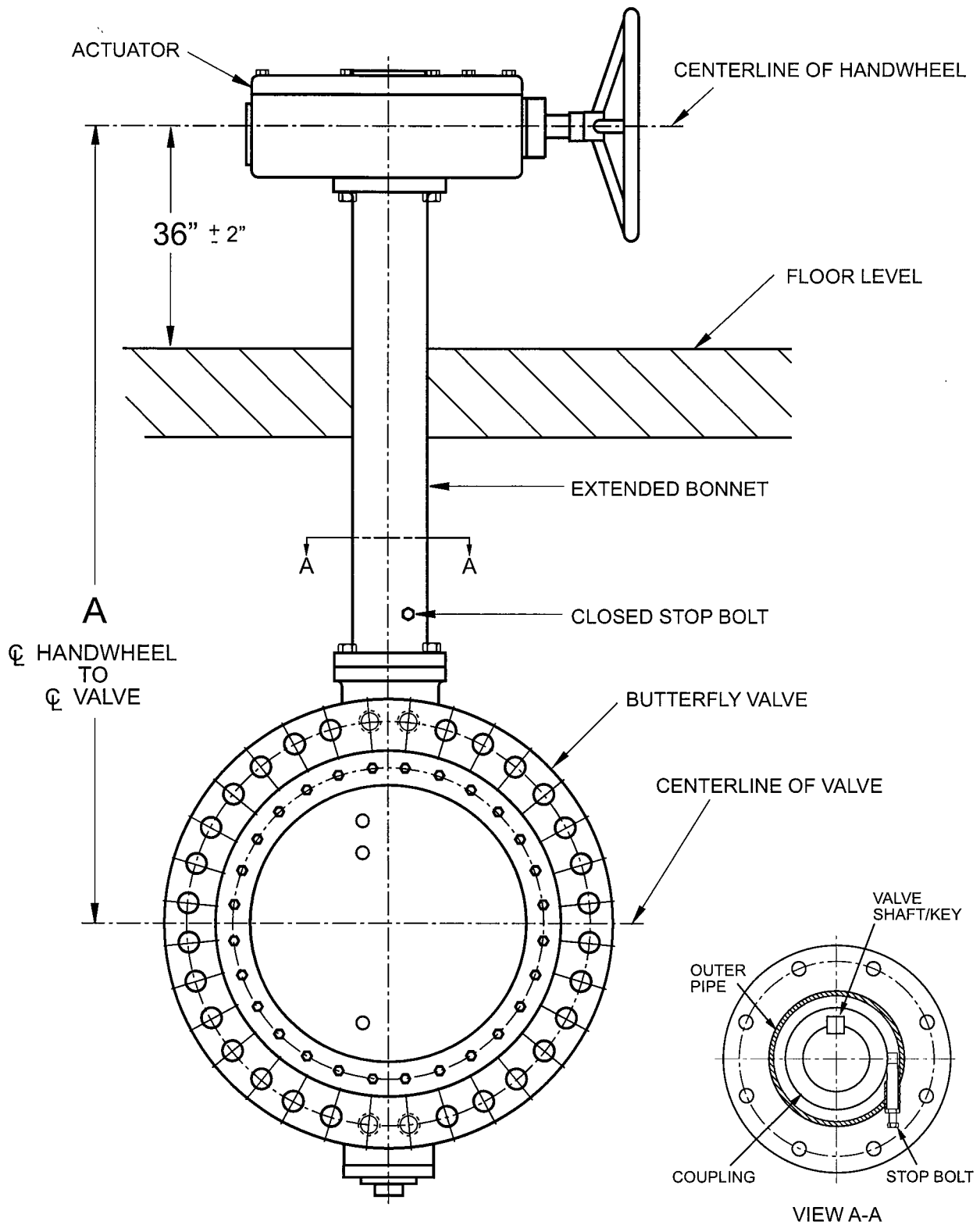

A - TO BE SPECIFIED BY CONTRACTOR FOR PROPER SIZING.

BUTTERFLY VALVE WITH EXTENDED BONNET

DATE 5-25-04

VAL-MATIC[®] VALVE AND MANUFACTURING CORP.

DRWG. NO.

VM-5EB/BFV

NOTES

1. THE DIRECTION OF OPENING MAY BE REVERSED BY CHANGING THE POSITION OF BEVEL GEAR (26). FOR OPEN LEFT, THE POSITIONS ARE:
LS-5.2A BOTTOM (DOTTED LINE)
LS-6A TOP (SOLID LINE)
LS-7A TOP (SOLID LINE)
2. OPERATOR MEETS AWWA SPECIFICATIONS C-504, LATEST REVISION.
3. SEE DRAWING NO. VM-LS5A.2-M FOR STANDARD MATERIALS OF CONSTRUCTION.

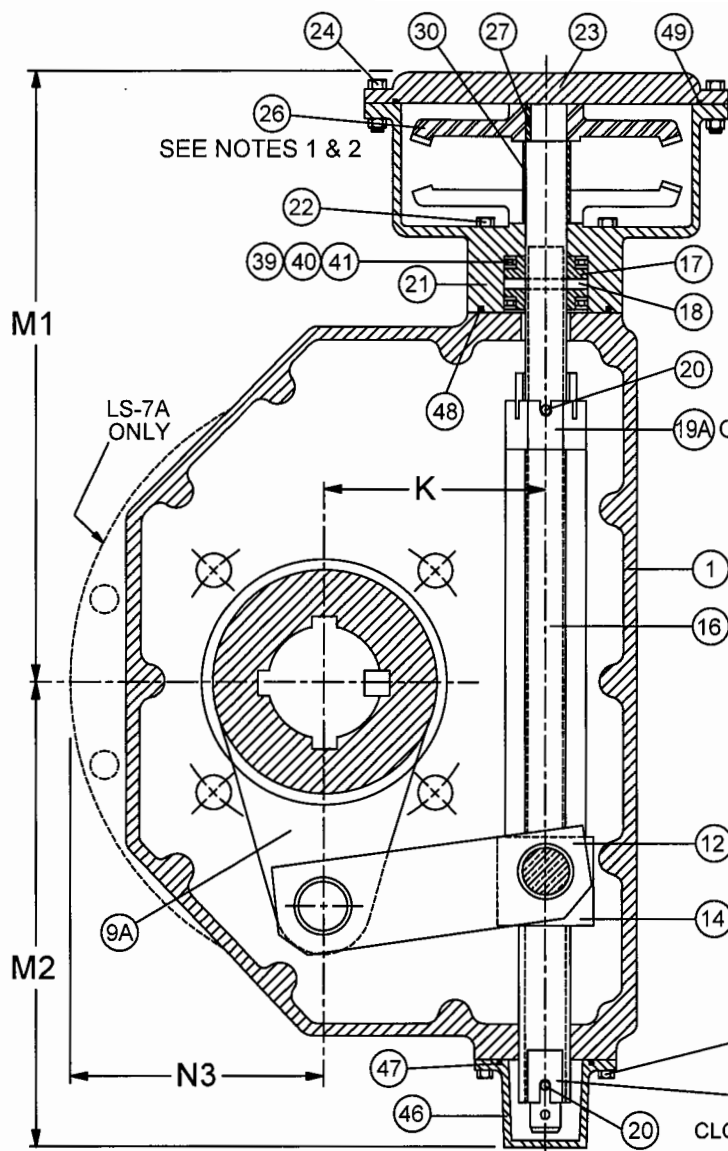

DIMENSION, INCHES									
ACT. SIZE	NO. OF TURNS	A	B	C	D	E	F	G	H
LS-5.2A	178	9.39	2.39	0.63	1.25	4.00	0.25	1.94	4.88
LS-6A	276	11.98	2.39	0.63	1.25	4.00	0.25	1.94	4.88
LS-7A	547	14.04	2.39	0.63	1.25	4.00	0.25	1.94	4.88

DIMENSION, INCHES									
ACT. SIZE	J	K	L1	L2	M1	M2	N1	N2	N3
LS-5.2A	0.44	8.50	5.13	10.91	23.34	17.75	6.25	12.13	—
LS-6A	0.44	10.50	6.50	13.59	29.44	21.88	8.63	15.13	—
LS-7A	0.44	14.00	9.00	18.71	37.40	28.75	9.00	20.25	13.13

INTEGRAL SOIL PIPE ALIGNMENT/ MOTOR ATTACHMENT FLANGE. (MEETS MSS SP-101, FA10)

KEYWAY
F WIDE X G LONG

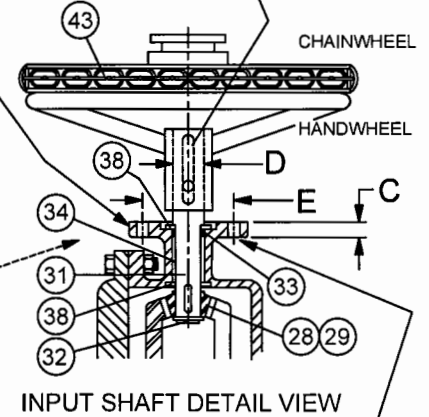

INPUT SHAFT DETAIL VIEW

(4) HOLES J DIA. STRADDLING CL

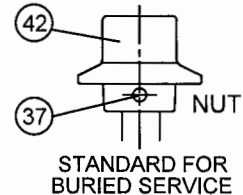

STANDARD FOR BURIED SERVICE

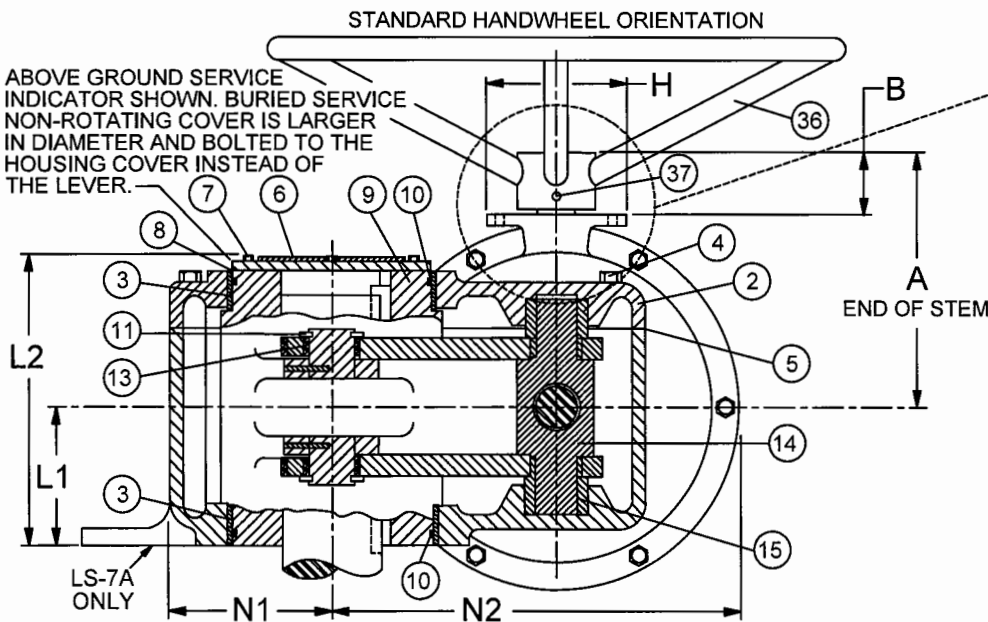

Revised 10-23-19

TRAVELING NUT ACTUATOR

DATE 8-22-08

VALMATIC VALVE AND MANUFACTURING CORP.

DRWG. NO.

VM-LS5.2A

TRAVELING NUT ACTUATOR

SIZES LS-5.2A THROUGH LS-7A

<u>PART NO.</u>	<u>PART NAME</u>	<u>MATERIAL</u>
1	OPERATOR HOUSING	CAST IRON ASTM A48, CLASS 40
2	HOUSING COVER	CAST IRON ASTM A48, CLASS 40
3	HOUSING & COVER BUSHINGS	TEFLON / FIBERGLASS BACKED
4	HOUSING COVER BOLTS	STAINLESS STEEL T316
5	HOUSING COVER GASKET	RTV SEALANT
6	INDICATOR SHAFT COVER (ABOVE GROUND SERVICE) NON-ROTATING SHAFT COVER (BURIED SERVICE)	CAST IRON ASTM A48, CLASS 40
7	SHAFT COVER BOLTS	STAINLESS STEEL T316
8	SHAFT COVER GASKET	RTV SEALANT
9	LEVER	DUCTILE IRON ASTM A536, GRADE 65-45-12
9A	LOCKING PIN	ALLOY STEEL
10	LEVER O-RING	BUNA-N
11	LEVER RETAINING RING	STEEL
12	LINK	STEEL
13	LINK BUSHING	TEFLON / FIBERGLASS BACKED
14	CROSSHEAD	BRONZE ASTM B124, ALLOY C67500
15	TRAVELING GUIDE	BRONZE ASTM B124, ALLOY C67500
16	OPERATOR STEM	HIGH TENSILE STEEL
17	STEM TRUST BEARING COLLAR	BRONZE ASTM B124, ALLOY C37700
18	STEM COLLAR PIN	STEEL
19	STOP NUT	STEEL
20	STOP NUT PIN	STEEL
21	BEVEL GEAR HOUSING	CAST IRON ASTM A48, CLASS 40
22	BEVEL GEAR HOUSING BOLTS	ALLOY STEEL
23	BEVEL GEAR HOUSING COVER	CAST IRON ASTM A48, CLASS 40
24	B.G. HOUSING COVER BOLTS	STAINLESS STEEL T316
26	BEVEL GEAR	STEEL
27	BEVEL GEAR KEY	STEEL
28	PINION GEAR	STEEL
29	PINION GEAR KEY	STEEL
30	SPACER	STEEL
31	INPUT SHAFT	STAINLESS STEEL T416, ASTM A582
32	SHAFT RETAINING RING	STEEL
33	INPUT SHAFT O-RING	BUNA-N
34	SHAFT BEARING	BRONZE
36	HANDWHEEL (OPTIONAL)	STEEL
37	PIN	STEEL
38	THRUST WASHER	BRONZE
39	BALL BEARINGS	STEEL
40	BEARING RACE	STEEL
42	OPERATING NUT (OPTIONAL FOR ABOVE GROUND SERVICE, STANDARD FOR BURIED SERVICE)	CAST IRON Stainless steel
43	CHAINWHEEL KIT (OPTIONAL)	DUCTILE IRON
46	STOP COVER	CAST IRON, ASTM A48, CLASS 40
47	STOP COVER O-RING	BUNA-N
48	BEVEL HOUSING O-RING	BUNA-N
49	BEVEL COVER O-RING	BUNA-N
50	STOP COVER BOLTS	STAINLESS STEEL T316

NOTE: ALL SPECIFICATIONS AS
LAST REVISED.

MATERIALS OF CONSTRUCTION

DATE 8/22/08

VAL-MATIC®

VALVE AND MANUFACTURING CORP.

DRWG. NO.

VM-LS5.2A-M

Gearbox Exterior

LIQUID EPOXY COATING

General Description:

Liquid Epoxy is a two-part, low VOC, chemically cured, semigloss coating that is applied as a liquid to the sandblasted surface of a valve and then allowed to cure at room temperature. The result is a durable coating with exceptional abrasion and chemical resistance ideally suited for valves in water and wastewater applications.

Advantages of Epoxy:

1. The coating is applied in accordance with AWWA Standard C550 "Protective Interior Coatings for Valves and Hydrants" and certified to the requirements of ANSI/ NSF Standard 61 - "Drinking Water System Components - Health Effects" for coating valves and fittings.
2. Epoxy coatings are applied in a spray process in one or multiple-coats.
3. The spray process provides a smooth, even coating thickness with no runs, sags, or thin spots common when applying liquid paints.
4. Epoxy has a long-term performance history in water and sewage environments including salt water, slurries, methane and hydrogen sulfide exposure.

Application Process:

1. The valve is cleaned and sandblasted, prior to coating.
2. Epoxy is applied in a semi-automated manufacturing process in accordance with the coating manufacturers' procedures and industry standards to assure consistency and high quality.
3. The epoxy is allowed to cure at room temperature.
4. The final surface is visually and electrically (when specified) tested to verify thickness and that it is holiday free.

Typical Performance Characteristics:

1. Color:	Black	
2. Thickness:	4-8 mils 12 mils min 4 Coat	
3. Impact Resistance:	20 in-lb	ASTM D2794
4. Moisture Permeability:	.07	ASTM E96
5. VOC:	1.41 lbs/gal	EPA 24
6. Service Temperature:	160° F. (250° F.)	Wet (Dry)
7. Adhesion:	Excellent	ASTM D4541
8. Abrasion:	Excellent	ASTM D4060
9. Elongation:	Excellent	ASTM D522 Method B
10. Water Immersion:	Excellent	ASTM D1308
11. Chemical Resistance to:	Alkalis, salts, oils, greases, foodstuffs, 50% sodium hydroxide, 28% ammonia, 25% citric acid, 5% sodium chloride, 10% ammonium hydroxide, sewage.	

Revised 6-29-23

LIQUID EPOXY COATING

DATE 11-25-03

VAL-MATIC®

VALVE AND MANUFACTURING CORP.

DRWG. NO.

SS-1939

(METERS OF WATER)

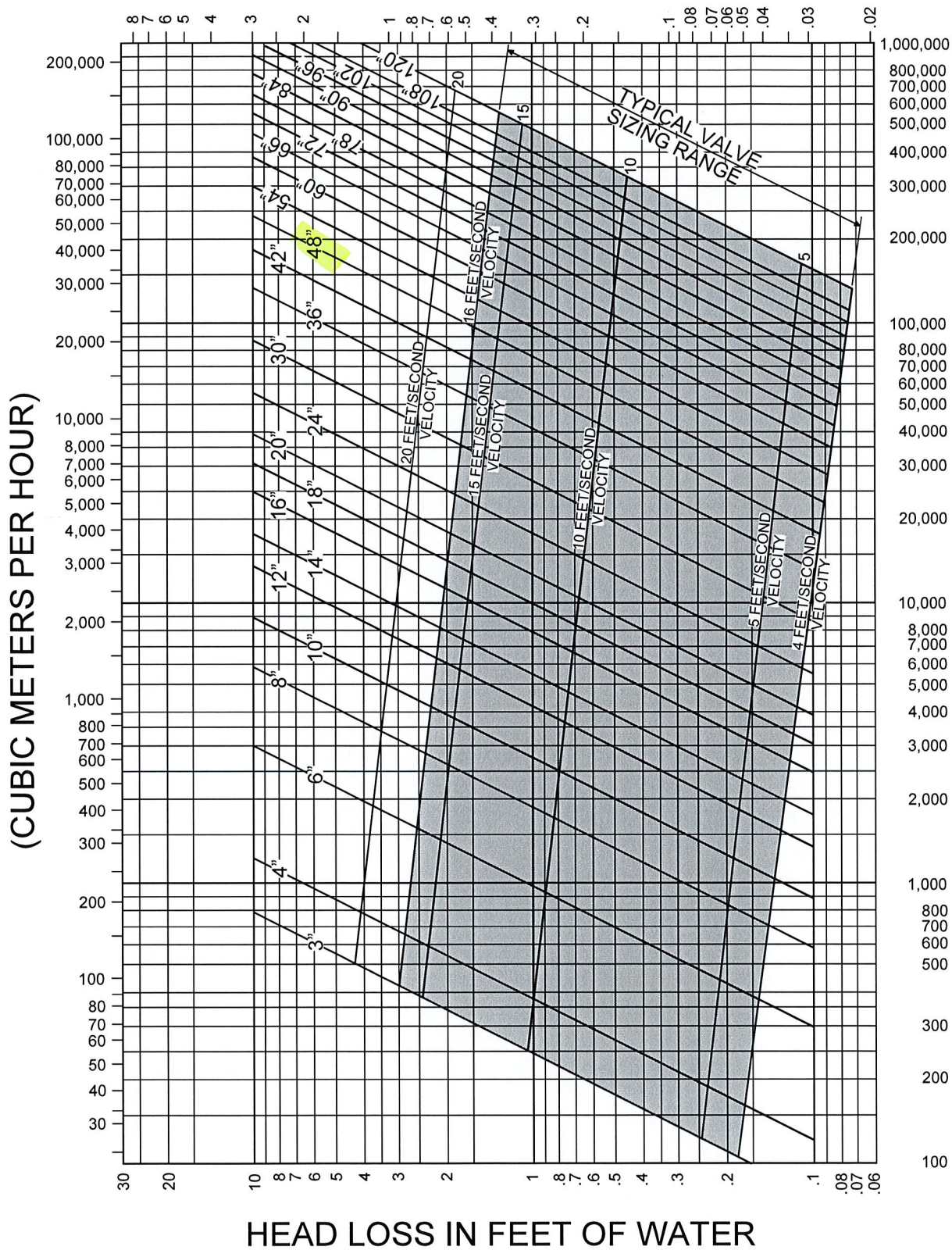

FLOW OF WATER IN GALLONS PER MINUTE

SIZE	3	4	6	8	10	12	14	16	18	20	24	30	36	42	48	54	60	66	72	78	84	90	96	102	108	120
Cv	380	590	1,430	2,750	4,300	6,550	8,350	11,800	15,000	18,600	27,000	42,000	61,900	87,100	114,000	144,000	180,000	221,000	266,500	316,000	366,000	420,500	478,500	540,000	605,500	744,000

HEAD LOSS CHART FOR CLASS 150B AND 250B BUTTERFLY VALVES

DATE Revised 11-5-18
5-26-99



VALVE AND MANUFACTURING CORP.

DRWG. NO.
SS-1622