



AGENDA – Board of Commissioners

Thursday, October 17, 2024 6:30 P.M.

- I. Call to Order and Pledge of Allegiance
- II. Roll Call
- III. Public Comments (limited to 3 minutes per person)
- IV. Approval of Minutes

(Concurrence of a Majority of those Commissioners Present, provided there is a quorum—minimum 4)

RECOMMENDED MOTION: To approve the Minutes of the September 19, 2024 Regular Meeting of the DuPage Water Commission.

V. Committee Reports

A. Finance Committee

1. Report of 10/17/24 Finance Committee
2. Resolution No. R-59-24: A Resolution to purchase workers' compensation and employer's liability insurance as proposed by Illinois Public Risk Fund and outlined by Arthur J. Gallagher Risk Management Services, Inc., at a cost of \$147,000, in accordance with Article VIII of the DuPage Water Commission bylaws.

(Affirmative Majority of the Appointed Commissioners, containing the votes of at least 1/3 of the County Appointed Commissioners and 40% of the Municipal Appointed Commissioners—3 County + 3 Muni+1=7)

3. Resolution No. R-69-24: A Resolution to approve the purchase of property and liability insurance as outlined in a letter of recommendation received from AJ Gallagher Risk Management Services, Inc., total premiums of approximately \$740,000, in accordance with Article VIII of the DuPage Water Commission bylaws.

(Affirmative Majority of the Appointed Commissioners, containing the votes of at least 1/3 of the County Appointed Commissioners and 40% of the Municipal Appointed Commissioners—3 County + 3 Muni+1=7)

RECOMMENDED MOTION: To adopt item numbers 2 and 3 under the Finance Committee Report section of the agenda in a single group pursuant to the Omnibus Vote procedures. (Roll Call)

4. Actions on other items listed on the 10/17/24 Finance Committee Agenda.

B. Administration Committee

1. Report of 10/17/24 Administration Committee

2. Ordinance O-7-24: An Ordinance Approving Amendments to the DuPage Water Commission Bylaws regarding preference for Illinois Bidders. Second Reading.

(Affirmative Majority of the Appointed Commissioners, containing the votes of at least 1/3 of the County Appointed Commissioners and 40% of the Municipal Appointed Commissioners—3 County + 3 Muni+1=7)

3. Resolution No. R-55-24: A Resolution Authorizing and Ratifying the Disposal of Certain Personal Property Owned by the DuPage Water Commission.

(Concurrence of a Majority of those Commissioners Present, provided there is a quorum—minimum 4)

4. Resolution No. R-58-24: A Resolution Retaining SPI Energy Group for Retail Electric Supply Market Consulting Services, at a not to exceed cost of \$16,000.

(Concurrence of a Majority of those Commissioners Present, provided there is a quorum—minimum 4)

5. Resolution No. R-60-24: A Resolution Approving a Water Purchase and Sale Agreement with the Village of Oswego

(Affirmative Majority of the Appointed Commissioners, containing the votes of at least 1/3 of the County Appointed Commissioners and 40% of the Municipal Appointed Commissioners—3 County + 3 Muni+1=7)

6. Resolution No. R-61-24: A Resolution Approving an Intergovernmental Agreement with the Village of Oswego Concerning Capital Cost Recovery Charge

(Affirmative Majority of the Appointed Commissioners, containing the votes of at least 1/3 of the County Appointed Commissioners and 40% of the Municipal Appointed Commissioners—3 County + 3 Muni+1=7)

7. Resolution No. R-62-24: A Resolution Approving a Water Purchase and Sale with the United City of Yorkville

(Affirmative Majority of the Appointed Commissioners, containing the votes of at least 1/3 of the County Appointed Commissioners and 40% of the Municipal Appointed Commissioners—3 County + 3 Muni+1=7)

8. Resolution No. R-63-24: A Resolution Approving an Intergovernmental Agreement with the United City of Yorkville Concerning Capital Cost Recovery Charge

(Affirmative Majority of the Appointed Commissioners, containing the votes of at least 1/3 of the County Appointed Commissioners and 40% of the Municipal Appointed Commissioners—3 County + 3 Muni+1=7)

9. Resolution No. R-64-24: A Resolution Approving a Water Purchase and Sale Contract with the Village of Montgomery

(Affirmative Majority of the Appointed Commissioners, containing the votes of at least 1/3 of the County Appointed Commissioners and 40% of the Municipal Appointed Commissioners—3 County + 3 Muni+1=7)

10. Resolution No. R-65-24: A Resolution Approving an Intergovernmental Agreement with the Village of Montgomery Concerning Capital Cost Recovery Charge

(Affirmative Majority of the Appointed Commissioners, containing the votes of at least 1/3 of the County Appointed Commissioners and 40% of the Municipal Appointed Commissioners—3 County + 3 Muni+1=7)

11. Resolution No. R-66-24: A Resolution Approving an Intergovernmental Agreement Concerning Development of Connection Facilities to Implement Water Service

(Affirmative Majority of the Appointed Commissioners, containing the votes of at least 1/3 of the County Appointed Commissioners and 40% of the Municipal Appointed Commissioners—3 County + 3 Muni+1=7)

12. Resolution No. R-67-24: A Resolution Approving WaterLink Project Escrow Intergovernmental Agreement

(Affirmative Majority of the Appointed Commissioners, containing the votes of at least 1/3 of the County Appointed Commissioners and 40% of the Municipal Appointed Commissioners—3 County + 3 Muni+1=7)

13. Resolution No. R-68-24: A Resolution Approving an Amendment to the WaterLink Second Escrow Intergovernmental Agreement

(Affirmative Majority of the Appointed Commissioners, containing the votes of at least 1/3 of the County Appointed Commissioners and 40% of the Municipal Appointed Commissioners—3 County + 3 Muni+1=7)

14. Request for Board Action: To Authorize the General Manager to approve Requisition No. 79341 in the amount of approximately \$61,000 to Hexagon (formerly Infor), in accordance with Article VIII of the DuPage Water Commission bylaws.

(Affirmative Majority of the Appointed Commissioners, containing the votes of at least 1/3 of the County Appointed Commissioners and 40% of the Municipal Appointed Commissioners—3 County + 3 Muni+1=7)

RECOMMENDED MOTION: To adopt item numbers 2 through 14 under the Administration Committee Report section of the agenda in a single group pursuant to the Omnibus Vote procedures. (Roll Call)

C. Engineering & Construction Committee

1. Report of 10/17/24 Engineering & Construction Committee

2. Resolution No. R-54-24: A Resolution Approving Hydro-Vacuum Cleaning Services with Badger Daylighting Corp at a Not to Exceed Cost of \$30,000.

(Affirmative Majority of the Appointed Commissioners, containing the votes of at least 1/3 of the County Appointed Commissioners and 40% of the Municipal Appointed Commissioners—3 County + 3 Muni+1=7)

3. Resolution No. R-56-24: A Resolution Approving and Ratifying Certain Change Orders to a Contract for the SCADA Replacement Project, Contract PSD 9/21 with Baxter & Woodman/Boller Construction, revising the Contract Price from \$15,546,598.83 to \$15,577,720.83.

(Affirmative Majority of the Appointed Commissioners, containing the votes of at least 1/3 of the County Appointed Commissioners and 40% of the Municipal Appointed Commissioners—3 County + 3 Muni+1=7)

RECOMMENDED MOTION: To adopt item numbers 2 and 3 under the Engineering & Construction Committee Report section of the agenda in a single group pursuant to the Omnibus Vote procedures. (Roll Call)

VI. Accounts Payable

A. September 2024

1. Approval of Accounts Payable invoices received.

RECOMMENDED MOTION: To approve the Accounts Payable in the amount of \$12,744,098.00 (September 2024), subject to submission of all contractually required documentation, for invoices that have been received (Roll Call).

(Affirmative Majority of the Appointed Commissioners, containing the votes of at least 1/3 of the County Appointed Commissioners and 40% of the Municipal Appointed Commissioners—3 County + 3 Muni+1=7)

2. Approval of Accounts Payable estimated invoices

RECOMMENDED MOTION: To approve the Accounts Payable in the amount of \$2,488,875.00 (September 2024), subject to submission of all contractually required documentation, for invoices that have not yet been received but have been estimated (Roll Call).

(Affirmative Majority of the Appointed Commissioners, containing the votes of at least 1/3 of the County Appointed Commissioners and 40% of the Municipal Appointed Commissioners—3 County + 3 Muni+1=7)

VII. Chairman’s Report

VIII. Old Business

IX. New Business

X. Executive Session

(Concurrence of a Majority of those Commissioners Present, provided there is a quorum—minimum 4)

RECOMMENDED MOTION: To go into Executive Session to discuss security procedures pursuant to 5 ILCS 120/2(c)(8), to discuss matters related to personnel pursuant to 5 ILCS 120/2(c)(1) and (2), to discuss acquisition of real estate pursuant to 5 ILCS 120/2(c)(5), to discuss the setting of a price for sale or lease of property owned by the DuPage Water Commission 5 ILCS 120/2(c)(6), to discuss pending, probable, or imminent litigation pursuant to 5 ILCS 120/2(c)(11), and/or to discuss minutes of closed meetings pursuant to 5 ILCS 120/2(c)(21) (Roll Call).

RECOMMENDED MOTION: To come out of Executive Session (Voice Vote).

XI. Adjournment

(Concurrence of a Majority of those Commissioners Present, provided there is a quorum—minimum 4)

Minutes of a Meeting
of the

BOARD OF COMMISSIONERS

DuPage Water Commission
600 E. Butterfield Road, Elmhurst, Illinois

September 19, 2024

I. The meeting was called to order by Chairman Zay at 6:32 PM

II. Roll Call

Commissioners in attendance: D. Bouckaert, N. Cuzzone, J. Fennell, J. Healy, J. Pruyn, K. Romano, D. Russo, F. Saverino, P. Suess, D. Van Vooren, J. Zay

Commissioners absent: D. Novotny, K. Rush

Also in attendance: P. May, C. Peterson, C. Bostick, M. Weed, J. Loster, D. Cuvalo, D. Mundall, Phil Luetkehans of Luetkehans, Brady, Garner & Armstrong, LLC

III. Public Comments

No public comment was offered.

IV. Plaque Presentation

Chairman Zay presented Commissioner James Healy with a plaque, honoring him for his years of service to the residents of DuPage County, both on the County Board and the DuPage Water Commissioner Board, and wishing him well in his future endeavors.

V. Approval of Minutes

Commissioner Healy moved to approve the Minutes of the August 15, 2024 Regular Meeting of the DuPage Water Commission. Seconded by Commissioner Russo. Approved by a voice vote. All Aye, motion carried.

VI. Treasurer's Report

Treasurer William Fates presented the August 2024 Treasurer's Reports consisting of 13 pages each with pages 1 and 2 containing brief summaries of the reports.

August 2024:

Treasurer Fates noted \$144.3 million of cash and investments on page 4, a decrease of \$0.3M from the previous month. Treasurer Fates also pointed out the schedule of investments on pages 5 through 11 totaling \$141.1 million and the market yield on the total portfolio showed 3.80% which is up slightly from the prior month. On page 12, the statement of cash flows showed a decrease in cash and investments by approximately \$87.8 million and operating activities decreased by

approximately \$3.9 million. Also noted on page 13, the monthly cash/operating report showed that the Commission has not met all recommended reserve balances.

Commissioner Pruyne moved to accept the August 2024 Treasurer's Reports, seconded by Commissioner Romano, unanimously approved by a voice vote. All aye, motion carried.

VII. Committee Reports

A. Finance Committee

Item 1: Commissioner Suess gave a brief report of the Finance Committee.

Item 2: Resolution No. R-50-24: A Resolution Amending the Reserve Fund Policy of the DuPage Water Commission.

Commissioner Suess moved to approve Resolution R-50-24, seconded by Commissioner Russo, unanimously approved by a Roll Call Vote.

Ayes: D. Bouckaert, N. Cuzzone, J. Fennell, J. Healy, J. Pruyne, K. Romano, D. Russo, F. Saverino, P. Suess, D. Van Vooren, J. Zay

Nay: None

Absent: D. Novotny, K. Rush

B. Administration Committee

Item 1: Commissioner Healy gave a brief report of the Administration Committee meeting.

Item 2: Recommendation to Receive and perform First Reading of Ordinance O-7-24: An Ordinance Approving Amendments to the DuPage Water Commission Bylaws regarding preference for Illinois Bidders.

Item 3: Resolution R-49-24: Authorization for the General Manager to approve the renewal of the additional 1-year option agreement with Sikich LLP for human resource consulting and services at the DuPage Water Commission, at a cost of \$250.00 per hour as needed.

Item 4: Resolution No. R-51-24: A Resolution Authorizing and Ratifying the disposal of certain personal property owned by the DuPage Water Commission.

Item 5: Request for Board Action: To approve the 2025 Schedule of Board Meetings.

Commissioner Healy made a motion to combine and approve Items 2 through 5. Seconded by Commissioner Van Vooren, unanimously approved by a Roll Call Vote.

Ayes: D. Bouckaert, N. Cuzzone, J. Fennell, J. Healy, J. Pruyne, K. Romano, D. Russo, F. Saverino, P. Suess, D. Van Vooren, J. Zay

Nay: None

Absent: D. Novotny, K. Rush

C. Engineering & Construction Committee

- Item 1: Commissioner Fennell gave a brief report of the Engineering & Construction Committee.
- Item 2: Resolution No. R-34-24: A Resolution to Approve & Ratify Certain Work Authorization Orders Under Quick Response Contract QR-12/21, WAO No. 25 Benchmark Construction Co., Inc. – Estimated Expense of \$100,824.00.
- Item 3: Resolution No. R-42-24: A Resolution Suspending Purchasing Procedures and Authorizing the General Manager to Purchase Replacement Switchgear Control Batteries, Labor Services, and Critical Spare Parts for the Generator Control System, at a Cost Not to Exceed \$140,000, from a sole Source Provider, Altorfer Industries.
- Item 4: Resolution No. R-48-24: A Resolution to Approve & Ratify Certain Work Authorization Orders Under Quick Response Contract QR-12/21, WAO No. 28 Benchmark Construction Co., Inc. – \$41,637.25.
- Item 5: Resolution No. R-52-24: A Resolution Approving and Ratifying Certain Change Orders for a Contract for the construction of the DPPS Emergency Generation System Modifications, Contract PSD-10/22, at an additional cost of \$45,577.22.
- Item 6: Resolution No. R-53-24: A Resolution Awarding a Contract for the Construction of Sacrificial Anode Groundbeds on TW-2 Pipeline, Contract TW-05/24, Rossi Contractors, Inc. - \$523,012.00.
- Item 7: Request for Board Action: Ratification of Purchase Order 41831 for Beary Landscaping to maintain the grounds of the Northbrook property, at a not to exceed cost of \$50,000.00

Commissioner Fennell moved to adopt item numbers 2 through 7 under the Engineering & Construction Committee Report section of the agenda in a single group pursuant to the Omnibus Vote Procedures seconded by Commissioner Bouckaert, unanimously approved by a Roll Call Vote.

Ayes: D. Bouckaert, N. Cuzzone, J. Fennell, J. Healy, J. Pruyne, K. Romano, D. Russo, F. Saverino, P. Suess, D. Van Vooren, J. Zay

Nay: None

Absent: D. Novotny, K. Rush

VIII. Accounts Payable

A. August 2024

Item 1: To approve the Accounts Payable in the amount of \$13,154,435.29 (August 2024), subject to submission of all contractually required documentation, for invoices that have been received (Roll Call).

Item 2: To approve the Accounts Payable in the amount of \$4,252,375.00 (August 2024), subject to submission of all contractually required documentation, for invoices that have not yet been received but have been estimated (Roll Call).

Chairman Zay asked for a motion to combine and approve the accounts payable disbursements, with the estimated accounts payable for August 2024, Commissioner Russo moved, seconded by Commissioner Cuzzone and unanimously approved by a roll call vote.

Ayes: D. Bouckaert, N. Cuzzone, J. Fennell, J. Healy, J. Pruyn, K. Romano, D. Russo, F. Saverino, P. Suess, D. Van Vooren, J. Zay

Nay: None

Absent: D. Novotny, K. Rush

IX. Chairman's Report

Chairman Zay informed the Commissioners that a meeting was held with the City of Chicago and negotiations are continuing. The Green Acres land study being done by Burke Engineering is complete' staff will review and propose a meeting with the Village of Northbrook. Commissioner Van Vooren asked if the site maintenance is being performed in compliance with Village codes. General Manager May replied that maintenance on the Green Acres property is ongoing and is fully compliant with additional pending work to be performed this winter after the ground freezes. A letter was sent out to all adjacent neighbors to keep them apprised as to the status.

Chairman Zay again thanked outgoing Commissioner Healy for his service and went on to mention County appointed Commissioners Bouckaert and Rush terms will end on January 1, 2025, as well as Municipally appointed Commissioners Saverino and Suess. He asked if those Commissioners would notify him of their intentions to return.

General Manager May indicated the WaterLink agreements will be brought forward at the October meeting. He went on the thank the staff and legal team for their work on these agreements.

X. Old Business

No Old Business was offered.

XI. New Business

No New Business was offered.

XII. Executive Session

Executive Session was not necessary.

XIII. Adjournment

Commissioner Healy made a motion to adjourn, seconded by Commissioner Russo, unanimously approved by a voice vote. All aye, motion carried.

Meeting adjourned at 6:47PM.



Resolution #: R-59-24

Account: 01-60-641500

Approvals: *Author / Manager / Finance / Admin*

CAP - CAP PDM

REQUEST FOR BOARD ACTION

Date: 10/8/2024

Description: **Workers' Compensation and Employer's Liability Insurance**

Agenda Section: Finance Committee

Originating Department: Finance

To purchase workers' compensation and employer's liability insurance with Illinois Public Risk Fund in the proposal received from AJ Gallagher Risk Management Services, Inc.

Recommended Motion:

Purchase Workers' Compensation and Employer's Liability Insurance (total premium of approximately \$147,000 as proposed by Illinois Public Risk Fund and outlined by AJ Gallagher Risk Management Services, Inc.)

DUPAGE WATER COMMISSION

RESOLUTION NO. R-59-24

A RESOLUTION APPROVING WORKERS' COMPENSATION AND EMPLOYER'S LIABILITY INSURANCE
FOR PLAN YEAR BEGINNING JANUARY 1, 2025 AND ENDING DECEMBER 31, 2025

WHEREAS, the Commission's Workers' Compensation coverage terminates at the end of the calendar year; and

WHEREAS the Commission annually renews workers' compensation coverage to be provided commencing January 1 of each year; and

WHEREAS, in consultation with AJ Gallagher Risk Management Services, Inc., Commission staff recommend approval of the Workers' Compensation and Employer's Liability Insurance as proposed by Illinois Public Risk Fund for the year beginning January 1, 2025 and ending December 31, 2025 summarized in Exhibit 1 attached hereto and by this reference incorporated herein.

NOW, THEREFORE, BE IT RESOLVED by the Board of Commissioners of the DuPage Water Commission as follows:

SECTION ONE: The foregoing recitals are incorporated herein and made a part hereof as findings of the Board of Commissioners of the DuPage Water Commission.

SECTION TWO: The Plan Year 2025 Workers' Compensation and Employer's Liability Insurance to be paid by the Commission, as summarized in Exhibit 1 attached hereto, shall be and they hereby are approved for the Plan Year 2025. The General Manager shall be and hereby is authorized and directed to provide the insurance coverages and pay the associated premium costs and administrative fees to be paid by the Commission as summarized in Exhibit 1 attached hereto without further act of the Board of Commissioners.

SECTION THREE: This Resolution shall be in full force and effect from and after its adoption.

	Aye	Nay	Absent	Abstain
Bouckaert, D.				
Cuzzone, N.				
Fennell, J.				
VACANT	_____			
Novotny, D.				
Pruyn, J.				
Romano, K.				
Rush, K.				
Russo, D.				
Saverino, F.				
Suess, P.				
Van Vooren, D.				
Zay, J.				

ADOPTED THIS ___ DAY OF _____, 2024.

James F. Zay, Chairman

ATTEST:

Danna Mundall, Clerk

Board/Resolutions/2024/R-59-24.docx

EXHIBIT 1



Insurance | Risk Management | Consulting

October 8, 2024

Ms. Cheryl Peterson
DuPage Water
Commission 600 East
Butterfield Road Elmhurst
IL 60126

Re: January 1, 2025 - January 1, 2026 Workers Compensation Renewal

Dear Cheryl,

The purpose of this letter is to provide the renewal quotation for the workers compensation program with the Illinois Public Risk Fund (IPRF).

The attached quotation summarizes the coverage and estimated renewal premium. The renewal premium is \$146,078, which is an increase of 15.08%. The premium includes a 4.57% increase in payroll over last year and a change in the experience mod from 1.02 to 1.54.

We recommend you approve the renewal.

Please contact us if you have any questions.

Thank you,

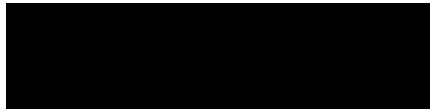

Rich Stokluska
Area Senior Executive Vice President



Resolution #: R-69-24

Account: 01-60-641100 01-60-641600
01-60-642100 01-60-642200

Approvals: *Author / Manager / Finance / Admin*

CAP - CAP PDM

REQUEST FOR BOARD ACTION

Date: 10/8/2024
Description: **Property and Liability Insurance**
Agenda Section: Finance Committee
Originating Department: Finance

Purchase Property and Liability Insurance total premium not to exceed \$740,000 based upon discussions with AJ Gallagher Risk Management Services, Inc. The increase is due to the following:

1. Property Insurance – A 11.6% increase to the overall premium is due to losses related to natural disasters causing higher deductibles and higher rates nationally. The industry has continued to see significant storms, which includes tornadoes, wind, and hail, in the Midwest region. In addition, a general 5% increase in asset values due to higher costs related to asset replacements driven by inflation and material supply chain issues, new assets, construction in process, and additional adjustments based upon an appraisal is included. The cost to insure Lexington is approximately \$144,000, 31% of the renewal cost.
2. General and Umbrella Liability coverage – Based on new carrier and they base rating different then past carriers. They include Board members. The increase in budget also contributed to the increase.
3. Excess Liability – In order to remain with the current limit of \$12 million, this coverage needs to be shared by two insurance carriers. One of the prior year carriers lowered their capacity to maintain coverage they were replaced for the same coverage at a higher cost.

Recommended Motion:

To purchase property and liability insurance as outlined in a letter of recommendation received from AJ Gallagher Risk Management Services, Inc.

DUPAGE WATER COMMISSION

RESOLUTION NO. R-69-24

A RESOLUTION APPROVING PROPERTY AND LIABILITY INSURANCE COVERAGE
FOR PLAN YEAR BEGINNING NOVEMBER 1, 2024 AND ENDING OCTOBER 31, 2025

WHEREAS, the Commission's Property and Liability renewal and deductible dates terminate at the end of the October 2024; and

WHEREAS the Commission annually determines employee insurance benefits to be provided commencing January 1 of each year; and

WHEREAS, in consultation with AJ Gallagher Risk Management Services, Inc., Commission staff recommend approval of the property and liability coverages for the year beginning November 1, 2024 and ending October 31, 2025 summarized in Exhibit 1 attached hereto and by this reference incorporated herein.

NOW, THEREFORE, BE IT RESOLVED by the Board of Commissioners of the DuPage Water Commission as follows:

SECTION ONE: The foregoing recitals are hereby incorporated herein and made a part hereof as findings of the Board of Commissioners of the DuPage Water Commission.

SECTION TWO The property and insurance liability premiums and brokerage fees to be paid by the Commission, all as summarized in Exhibit 1 attached hereto, shall be and they hereby are approved for the fiscal year November 1, 2024 to October 31, 2025. The General Manager shall be and hereby is authorized and directed to bind the proposed coverages and pay the associated premium costs and brokerage fees to as summarized in Exhibit 1 attached hereto without further act of the Board of Commissioners.

SECTION THREE: This Resolution shall be in full force and effect from and after its adoption.

	Aye	Nay	Absent	Abstain
Bouckaert, D.				
Cuzzone, N.				
Fennell, J.				
VACANT	<hr style="border: 1px solid black;"/>			
Novotny, D.				
Pruyn, J.				
Romano, K.				
Rush, K.				
Russo, D.				
Saverino, F.				
Suess, P.				
Van Vooren, D.				
Zay, J.				

ADOPTED THIS ___ DAY OF _____, 2024.

James F. Zay, Chairman

ATTEST:

Danna Mundall, Clerk
Board/Resolutions/2024/R-69-24.docx

EXHIBIT 1

October 8, 2024

Ms. Cheryl Peterson
DuPage Water Commission
600 East Butterfield Road
Elmhurst IL 60126

Re: November 2024-25 Renewals

Dear Cheryl,

The purpose of this letter is to provide the results of the renewal negotiations for the insurance coverage that renews in November for the 2024-2025 term. The cost comparison is provided on the attached spreadsheet.

- We recommend the general liability, lead excess liability (\$10M), auto, public officials and management liability coverage remain with Allied Public Risk/Munich Re Company.
- We recommend the excess liability (\$6M part of \$12M XS \$10M) be renewed with Markel/Evanston.
- We recommend the excess liability (\$6M part of \$12M XS \$10M) be renewed with Great American.
- We recommend the property coverage remain with American Home Insurance/AIG.
- We recommend the underground storage tank be renewed with Ironshore/Liberty Mutual.
- We recommend that pollution be renewed with Ironshore.
- We recommend that you move your cyber coverage from Travelers to AmTrust.
- We recommend the crime coverage remain with Hanover.

Please contact us if you have any questions.

Thank you,



Rich Stokluska
Area Senior Executive Vice President

DuPage Water Commission			
2024 Renewal Cost Comparison			
Coverage	2023	2024	% Change
General/Auto Liability /Public Official	\$75,732	\$87,929	16.1%
Crime	\$977	\$977	0%
Lead Excess Liability	\$25,383	\$27,481	8.27%
Excess Liability	\$43,486	\$50,885	17.0%
Property	\$414,800	\$462,983	11.62%
Underground Storage Tank	\$4,309	\$4,545.51	5.5%
Pollution*	\$37,486.14	\$38,211	1.9%
Cyber**	\$56,769	\$33,428	-41.1%
Brokerage Fee	\$30,385	\$30,385	0%
Total Cost:	\$689,327	\$736,825	6.9%
Insurers	2023	2024	Comments
General Liability	Allied Public Risk/Midvale	Allied Public Risk/Munich Re	
Automobile	Allied Public Risk/Midvale	Allied Public Risk/Munich Re	
Crime	Hanover	Hanover	
Lead Excess Liability	Allied Public Risk/Midvale	Allied Public Risk/Munich Re	
Excess Liability	Markel/Acceptance Indemnity	Markel / Great American	Quota Share - \$6M each carrier
Property	American Home	American Home	
Underground Storage Tank	Ironshore	Ironshore	
Pollution*	Ironshore	Ironshore	
Cyber**	Travelers	AmTrust	
Limits	2023	2024	Comments
General Liability / Public Officials	\$1 Mil / \$3 Mil	\$1 Mil / \$3 Mil	
Automobile	\$1,000,000	\$1,000,000	
Crime	\$250,000	\$250,000	
Lead Excess Liability	\$10,000,000	\$10,000,000	
Excess Liability	\$12,000,000 (Quota Share)	\$12,000,000 (Quota Share)	
Property	\$250,000,000	\$250,000,000	
Underground Storage Tank	\$1 Mil / \$3 Mil	\$1 Mil / \$3 Mil	
Pollution*	\$10 Mil each/agg	\$10 Mil each/agg	
Cyber**	\$3 Mil	\$3 Mil	
Deductibles	2023	2024	Comments
General Liability	\$5,000	\$5,000	
Automobile	\$500 Phys Dam	\$1,000 Phys Dam	Munich's new carrier requirement
Crime	\$25,000	\$25,000	
Property	\$150,000 \$500,000 Windstorm/Hail Deductible	\$150,000 \$500,000 Windstorm/Hail Deductible	
Underground Storage Tank	\$5,000	\$5,000	
Pollution*	\$25,000	\$25,000	
Cyber**	\$50,000	\$50,000	
Pollution* 3 Year Term - 2024-2027			
Cyber** 2023 was an extended term policy - 5/31/2023 to 11/1/2024			



Resolution #: [ORDINANCE] O-7-24

Account: N/A

Approvals: *Author / Manager / Finance / Admin*

PDM - CAP PDM

REQUEST FOR BOARD ACTION

Date: 10/10/2024

Description: **By-Law Amendment to permit Illinois Bidder Preference**

Agenda Section: Administration Committee

Originating Department: Administration

Article VIII of the DuPage Water Commission by-laws describes the purchasing procedures for the Commission. Section 11 of Article VIII and corresponding state law provides broad authority to the DWC Board for the award of a contracts; this authority is often utilized to ensure that DWC retains standardized components throughout our system (rather than “or-equal” elements) for critical infrastructure such as valves, and that we acknowledge and utilize proprietary systems, methods, and vendors to maintain infrastructure integrity and warranties (such as utilizing only CAT-authorized vendors to maintain the Caterpillar generators systems).

The approaching WaterLink construction project along with other scheduled large-diameter pipeline projects in the region, will present an unusual demand on the qualified contractor pool and is likely to attract contractor interest from outside the region. While DWC supports and encourages the largest degree of competition possible during the bidding process, it is equally important that we are well-positioned to disqualify contractors with inadequate experience or work history. While existing Section 11 purchasing authority provides a sound rationale to reject bids that are not in the best interest of the Commission, we believe this language could be strengthened by allowing the DWC to include an Illinois bidder’s preference.

The recommended by-law changes do not require a local bidder preference for all DWC contracts, but only permits DWC specify it when we anticipate a benefit (such as for the WaterLink project). It is also important to note that the recommended language does not require DWC to award a contract to a higher-cost local contractor, but simply provides a qualified Illinois contractor an opportunity to match the low-bid price from the out-of-state contractor if the bids are within 4%.

Recommended Motion:

This Ordinance presents a modification to the DWC By-Laws and requires two readings. It is presented for consideration at the 9/19/2024 Board of Commissioners meeting with a recommendation that it be included on the 10/17/2024 Board of Commissioners meeting for approval.

DUPAGE WATER COMMISSION

ORDINANCE NO. O-7-24

AN ORDINANCE APPROVING AMENDMENTS TO THE DUPAGE WATER COMMISSION BYLAWS
REGARDING PREFERENCE FOR ILLINOIS BIDDERS

WHEREAS, the DuPage Water Commission (the “Commission”) was formed and exists pursuant to the Water Commission Act of 1985, 70 ILCS 3720/0.01 et seq., and Division 135 of Article 11 of the Illinois Municipal Code, 65 ILCS 5/11-135-1 et seq., for the purpose of securing an adequate source and supply of water for its customers; and

WHEREAS, the Commission previously adopted Bylaws for the management and operation of the Commission, including purchasing procedures, which Bylaws have been amended from time to time;

WHEREAS, the Commission has determined that the Bylaws should be amended to incorporate a preference for Illinois bidders when specified;

WHEREAS, the Commission conducted a first reading of the amended Bylaws on September 19, 2024 and a second reading on October 17, 2024; and

WHEREAS, the Commission deems it to be in the best interests of the Commission to approve the amendment of Article VIII of the Bylaws.

NOW, THEREFORE, BE IT ORDAINED by the Board of Commissioners of the DuPage Water Commission as follows:

SECTION ONE: The foregoing recitals are hereby incorporated herein and made a part hereof as findings of the Board of Commissioners of the DuPage Water Commission.

SECTION TWO: Article VIII of the Bylaws regarding Purchasing Procedures is Amended as set forth on Exhibit 1 attached hereto and incorporated herein.

SECTION THREE: This Ordinance shall be in full force and effect from and after its adoption.

	Aye	Nay	Absent	Abstain
Bouckaert, D.				
Cuzzone, N.				
Fennell, J.				
VACANT	_____			
Novotny, D.				
Pruyn, J.				
Romano, K.				
Rush, K.				
Russo, D.				
Saverino, F.				
Suess, P.				
Van Vooren, D.				
Zay, J.				

ADOPTED THIS _____ DAY OF _____, 2024.

James Zay, Chairman

ATTEST:

Danna Mundall, Clerk

EXHIBIT 1

ARTICLE VIII

PURCHASING PROCEDURES

Section 1: Coverage. These procedures shall cover all contracts for supplies, material or work being purchased by the Commission except as herein set forth.

Section 2: Definitions. For the purpose of these procedures, “supplies, material or work” shall mean and include, except as hereinafter limited, all work, labor or services; other contracts for services; supplies, equipment or other materials; and the rental, repair or maintenance of equipment, machinery and other personal property. The term “work” shall not include services rendered in a professional capacity such as accounting, engineering or legal services.

Section 3: Minor Purchases. The General Manager shall have the authority to purchase on behalf of the Commission supplies, material or work requiring an expenditure of the sum provided for in 65 ILCS 5/8-9-1 or less pursuant to such procedures as he or she deems calculated to insure the best interests of the Commission, without a specific solicitation of quotations or advertisement for bids.

Section 4: Purchases Requiring Quotations. All purchases of supplies, material or work included in the Annual Management Budget and requiring expenditure in excess of the sum provided for in 65 ILCS 5/8-9-1 shall be made only after the solicitation of at least two written quotations. All such quotations shall be submitted sealed to the Commission and shall be opened in public at a date and time set by the General Manager. A tabulation of all quotations received shall be presented to the Board of Commissioners. In cases where only one quotation is received, there is only a single source for the supplies, materials or work or the purchase was not included in the Annual Management Budget,

the expenditure may only be authorized by the Board of Commissioners. The General Manager shall keep a record of all such purchases and the quotations submitted pursuant to the solicitation therefor.

Section 5: Other Contracts. All contracts, except those provided for in Section 3 and Section 4 of this Article VIII shall be entered into only after advertising for bids in the manner required by the Water Commission Statute.

Section 6: Bid Deposits. When deemed necessary by the General Manager or Board of Commissioners, bid deposits shall be required.

Section 7: Specifications. The following shall apply to specifications.

- a. Specifications shall be available to all bidders;
- b. Specifications shall be general in nature and not so specific as to limit a bidder to a specific brand; and
- c. The Commission shall reserve the right to make clarifications, corrections or changes in specifications at any time prior to the time bids are opened so long as all bidders or prospective bidders are informed of said clarifications, corrections or changes in the specifications.

Section 8: Bid Opening Procedure.

- a. Sealed. Bids shall be submitted sealed to the Commission and shall be identified as bids on the envelopes. The date and time the bid was received shall be recorded on the envelope of the bid.
- b. Opening. Bids shall be opened in public at the time and place stated in the public notices.

- c. Tabulation. A tabulation of all bids received shall be available for public inspection.

Section 9: Acceptance or Rejection of Bids. Except when expressly and specifically limited by the terms of a particular bid solicitation, the Commission shall have the authority to accept the bid which, in its judgment, is the best bid and most favorable to the interests of the Commission and the public; to reject the low bid; to award to other than the lowest bidder; to accept any item of any bid; to reject any and all bids; to accept and incorporate corrections or clarifications following bid opening when to do so would not, in the Commission's opinion, prejudice the bidding process or create any improper advantage to bidders; and to waive irregularities and informalities in any bid submitted or in the bidding process.

Section 10: Bidders in Default to Commission. The Commission shall not accept the bid of a contractor who is or has been in default on a contract with the Commission or in the payment of monies due to the Commission.

Section 11: Award of Contract.

- a. Authority in Board of Commissioners. The Board of Commissioners shall have the authority to award all contracts for the construction of the Commission's water supply system.
- b. Awards. Contracts shall be awarded to the bidder whose proposal is found to be in the best interests of the Commission. In determining the bidder who is to receive the award, the Commission shall consider the following factors in addition to price:

- (i) The ability, capacity and skill of the bidder to perform the contract or provide the service required;
- (ii) Whether the bidder has the requisite facilities, plant, organization and staffing to enable the bidder to perform the contract or provide the service successfully and promptly, within the time specified, without delay or interference;
- (iii) The character, integrity, reputation, judgment, experience and efficiency of the bidder;
- (iv) The quality of the bidder's performance of previous contracts or services;
- (v) The previous and existing compliance by the bidder with the laws and ordinances relating to the contract or services;
- (vi) The sufficiency of the financial resources and ability of the bidder to perform the contract or to provide the services;
- (vii) The quality, availability, adaptability and capabilities of the supplies, material or work to the particular use required;
- (viii) The ability of the bidder to provide future maintenance and service for the subject of the contract, if applicable;

- (ix) Any other factor that the Commission may legally consider in determining the proposal that is in the best interests of the Commission;
- (x) If the contract is for “public works” as that term is defined in the Illinois Prevailing Wage Act (820 ILCS 130/0.01 *et seq.*), the following factors shall also be considered:
 - a. The ability of the bidder to provide future maintenance and service for the subject of the contract, if applicable;
 - b. The bidder and its subcontractors must comply with all provisions of the Illinois Prevailing Wage Act, (820 ILCS 130/0.01 *et seq.*), including wages, medical and hospitalization insurance and retirement for those trades covered under the Act; and
 - c. The bidder and all bidder’s subcontractors must participate in active apprenticeship and training programs approved and registered with the United State Department of Labor’s Office of Apprenticeship for each of the trades of work contemplated under the contract.

(xi) Authority to specify a Preference For Qualified Illinois Bidders. To the extent not prohibited by federal or state statute, regulation or law and notwithstanding any provisions of this Article VIII to the contrary, ~~it shall be the policy of the Commission shall be empowered to specify a preference to procure goods and services from qualified Illinois bidders to the greatest extent possible~~ when deemed to be in the best interests of the Commission. When the Commission specifies a preference for Illinois bidders in the procurement of goods and services, the following will apply:

a. Applicability. This Section does not apply to any contract for any project for which the Commission has received or will receive federal funds for the project when receipt of such funds may be in conflict with federal law or federal regulation.

b. Definition. As used in this Section, “qualified Illinois business” means a contractor that is operating and headquartered in Illinois and providing, at the time that an invitation for a bid or notice of contract opportunity is first

advertised, construction or construction-related professional services, and is operating as:

- i. a sole proprietor whose primary residence is in Illinois;
- ii. a business incorporated or organized as a domestic corporation under the Business Corporation Act of 1983 (805 ILCS 5/1.01 et seq.);
- iii. a business organized as a domestic partnership under the Uniform Partnership Act of 1997 (805 ILCS 206/100 et seq.);
- iv. a business organized as a domestic limited partnership under the Uniform Limited Partnership Act of 2001 (805 ILCS 215/0.01 et seq);
- v. a business organized under the Limited Liability Company Act (805 ILCS 180/1-1 et seq.); or
- vi. a business organized under the Professional Limited Liability Company Act (805 ILCS 185/1 et seq.);

vii. A joint venture in which each joint venturer satisfies one of the qualifications of i – vi above.

c. Notice Of Intent To Match Low Bid. If the lowest responsive, responsible bidder is not a qualified Illinois bidder and if a qualified Illinois bidder has submitted a bid which is within four percent (4%) of the lowest responsive, responsible bidder for an item or bid, the qualified Illinois bidder shall be given written notice to that effect and may, within five (5) days from the date of such notice, provide written confirmation to the Commission that it will match the bid price of the lowest responsive, responsible bidder. The qualified Illinois bidder shall, where the bid is an aggregate of separate price components, reduce the price of each separate component of its aggregate bid by the same percentage that was used to match the bid of the lowest responsive, responsible bidder. If a qualified Illinois bidder fails to provide such written confirmation within the time allowed, its bid shall be considered as originally submitted.

- d. Multiple Qualified Illinois bidders. If more than one qualified Illinois bidder is within four percent (4%) of the lowest responsive, responsible bidder, only the qualified Illinois bidder submitting the lowest bid shall be given the opportunity to match the bid of the lowest responsive, responsible bidder. The qualified Illinois bidder shall, where the bid is an aggregate of separate price components, reduce the price of each separate component of its aggregate bid by the same percentage that was used to match the bid of the lowest responsive, responsible bidder.
- e. Rejection of Bids. The Commission may reject any and all bids and award the contract to a bidder other than the lowest responsive, responsible bidder or a qualified Illinois bidder who matches the lowest responsible bid upon the determination of the Commission that it is in the Authority's best interests to do so.
- f. Certification. A bidder shall certify in its bid or proposal whether it is a qualified Illinois bidder under this Code.

- c. Subsequent Awards. Contracts awarded to a bidder who fails to comply with all conditions precedent to formal execution of the contract agreement may be annulled. Upon annulment of an award, the Commission may award the contract to any other bidder whose proposal is found to be in the best interests of the Commission in accordance with Subsection 11(b) above, or the Commission may advertise anew for bids.

Section 12: Single Bids. The Board of Commissioners desires competitive bids; however, where there is only one bid, that fact alone shall not prevent the Commission from accepting that bid.

Section 13: Performance and Payment Bonds. The Commission may require a performance bond before entering a contract in such amount as it shall find reasonably necessary to protect the best interests of the Commission. The Commission shall require a payment bond in such amount as it shall find reasonably necessary to secure payment for material used and labor performed in connection with a public work.

Section 14: Change Orders. All contract change orders shall be considered and approved or disapproved by the Commission during the regular course of its conduct of business except in the following circumstances.

- a. By General Manager. The General Manager shall have the authority to approve any contract change order:
 - (i) based entirely upon approved unit prices; or
 - (ii) In an amount not in excess of \$100,000 when in the judgment of the General Manager and the

Commission's consulting engineer such change order requires immediate approval to avoid significant impacts to the project schedule or the incurring of unnecessary and excessive costs by the Commission.

A full written description and explanation of any change order so approved by the General Manager shall be distributed to the Board of Commissioners as soon as possible following its approval.

- b. By Commission at Special or Emergency Meeting. When in the judgment of the General Manager a change order in an amount in excess of \$100,000 requires a more immediate approval than the Commission's regular meeting schedule would permit in order to avoid the incurring of significant impacts to the project schedule or unnecessary and excessive costs by the Commission, or when, in any other case, in the judgment of the General Manager a change order requires the immediate attention of the Commission, the General Manager may call a special or emergency meeting of the Commission for the consideration of such change order.

Section 15: Prohibition Against Subdivision. No contract or change order shall be subdivided to avoid the requirements of these By-Laws. This prohibition shall not prevent the repetitive purchase of supplies, material or work which is purchased over a period of time as needed.

Section 16: Emergencies. In case of an apparent emergency which requires immediate purchase of supplies, material or work to protect persons or property, the

General Manager shall be authorized to secure any supplies, material or work necessary to address such emergency by whatever means deemed necessary without regard to the procedures otherwise required under these By-Laws. A full written description and explanation of any such emergency purchase shall be distributed to the Board of Commissioners as soon as possible following the emergency.

Section 17: Bid Item Must Be Budgeted. Contracts or purchase orders cannot be executed and are invalid and void unless the amounts due there under have been budgeted by the Board of Commissioners.

Section 18: Cooperative Purchasing Arrangements. Nothing in this Article VIII shall be interpreted to prohibit the Commission from participating with other public bodies, associations or agencies, or with other units of government, in any cooperative purchasing arrangements subject to bidding or other processes that assure the protection of the best interests of the Commission. Supplies, materials or work purchased through such arrangement shall be exempted from the requirements of this Article.

ARTICLE VIII

PURCHASING PROCEDURES

Section 1: Coverage. These procedures shall cover all contracts for supplies, material or work being purchased by the Commission except as herein set forth.

Section 2: Definitions. For the purpose of these procedures, “supplies, material or work” shall mean and include, except as hereinafter limited, all work, labor or services; other contracts for services; supplies, equipment or other materials; and the rental, repair or maintenance of equipment, machinery and other personal property. The term “work” shall not include services rendered in a professional capacity such as accounting, engineering or legal services.

Section 3: Minor Purchases. The General Manager shall have the authority to purchase on behalf of the Commission supplies, material or work requiring an expenditure of the sum provided for in 65 ILCS 5/8-9-1 or less pursuant to such procedures as he or she deems calculated to insure the best interests of the Commission, without a specific solicitation of quotations or advertisement for bids.

Section 4: Purchases Requiring Quotations. All purchases of supplies, material or work included in the Annual Management Budget and requiring expenditure in excess of the sum provided for in 65 ILCS 5/8-9-1 shall be made only after the solicitation of at least two written quotations. All such quotations shall be submitted sealed to the Commission and shall be opened in public at a date and time set by the General Manager. A tabulation of all quotations received shall be presented to the Board of Commissioners. In cases where only one quotation is received, there is only a single source for the supplies, materials or work or the purchase was not included in the Annual Management Budget,

the expenditure may only be authorized by the Board of Commissioners. The General Manager shall keep a record of all such purchases and the quotations submitted pursuant to the solicitation therefor.

Section 5: Other Contracts. All contracts, except those provided for in Section 3 and Section 4 of this Article VIII shall be entered into only after advertising for bids in the manner required by the Water Commission Statute.

Section 6: Bid Deposits. When deemed necessary by the General Manager or Board of Commissioners, bid deposits shall be required.

Section 7: Specifications. The following shall apply to specifications.

- a. Specifications shall be available to all bidders;
- b. Specifications shall be general in nature and not so specific as to limit a bidder to a specific brand; and
- c. The Commission shall reserve the right to make clarifications, corrections or changes in specifications at any time prior to the time bids are opened so long as all bidders or prospective bidders are informed of said clarifications, corrections or changes in the specifications.

Section 8: Bid Opening Procedure.

- a. Sealed. Bids shall be submitted sealed to the Commission and shall be identified as bids on the envelopes. The date and time the bid was received shall be recorded on the envelope of the bid.
- b. Opening. Bids shall be opened in public at the time and place stated in the public notices.

- c. Tabulation. A tabulation of all bids received shall be available for public inspection.

Section 9: Acceptance or Rejection of Bids. Except when expressly and specifically limited by the terms of a particular bid solicitation, the Commission shall have the authority to accept the bid which, in its judgment, is the best bid and most favorable to the interests of the Commission and the public; to reject the low bid; to award to other than the lowest bidder; to accept any item of any bid; to reject any and all bids; to accept and incorporate corrections or clarifications following bid opening when to do so would not, in the Commission's opinion, prejudice the bidding process or create any improper advantage to bidders; and to waive irregularities and informalities in any bid submitted or in the bidding process.

Section 10: Bidders in Default to Commission. The Commission shall not accept the bid of a contractor who is or has been in default on a contract with the Commission or in the payment of monies due to the Commission.

Section 11: Award of Contract.

- a. Authority in Board of Commissioners. The Board of Commissioners shall have the authority to award all contracts for the construction of the Commission's water supply system.
- b. Awards. Contracts shall be awarded to the bidder whose proposal is found to be in the best interests of the Commission. In determining the bidder who is to receive the award, the Commission shall consider the following factors in addition to price:

- (i) The ability, capacity and skill of the bidder to perform the contract or provide the service required;
- (ii) Whether the bidder has the requisite facilities, plant, organization and staffing to enable the bidder to perform the contract or provide the service successfully and promptly, within the time specified, without delay or interference;
- (iii) The character, integrity, reputation, judgment, experience and efficiency of the bidder;
- (iv) The quality of the bidder's performance of previous contracts or services;
- (v) The previous and existing compliance by the bidder with the laws and ordinances relating to the contract or services;
- (vi) The sufficiency of the financial resources and ability of the bidder to perform the contract or to provide the services;
- (vii) The quality, availability, adaptability and capabilities of the supplies, material or work to the particular use required;
- (viii) The ability of the bidder to provide future maintenance and service for the subject of the contract, if applicable;

- (ix) Any other factor that the Commission may legally consider in determining the proposal that is in the best interests of the Commission;
- (x) If the contract is for “public works” as that term is defined in the Illinois Prevailing Wage Act (820 ILCS 130/0.01 *et seq.*), the following factors shall also be considered:
 - a. The ability of the bidder to provide future maintenance and service for the subject of the contract, if applicable;
 - b. The bidder and its subcontractors must comply with all provisions of the Illinois Prevailing Wage Act, (820 ILCS 130/0.01 *et seq.*), including wages, medical and hospitalization insurance and retirement for those trades covered under the Act; and
 - c. The bidder and all bidder’s subcontractors must participate in active apprenticeship and training programs approved and registered with the United State Department of Labor’s Office of Apprenticeship for each of the trades of work contemplated under the contract.

(xi) Authority to specify a preference For Qualified Illinois Bidders. To the extent not prohibited by federal or state statute, regulation or law and notwithstanding any provisions of this Article VIII to the contrary, the Commission shall be empowered to specify a preference to procure goods and services from qualified Illinois bidders when deemed to be in the best interests of the Commission. When the Commission specifies a preference for Illinois bidders in the procurement of goods and services, the following will apply:

- a. Applicability. This Section does not apply to any contract for any project for which the Commission has received or will receive federal funds for the project when receipt of such funds may be in conflict with federal law or federal regulation.
- b. Definition. As used in this Section, “qualified Illinois business” means a contractor that is operating and headquartered in Illinois and providing, at the time that an invitation for a bid or notice of contract opportunity is first

advertised, construction or construction-related professional services, and is operating as:

- i. a sole proprietor whose primary residence is in Illinois;
- ii. a business incorporated or organized as a domestic corporation under the Business Corporation Act of 1983 (805 ILCS 5/1.01 et seq.);
- iii. a business organized as a domestic partnership under the Uniform Partnership Act of 1997 (805 ILCS 206/100 et seq.);
- iv. a business organized as a domestic limited partnership under the Uniform Limited Partnership Act of 2001 (805 ILCS 215/0.01 et seq);
- v. a business organized under the Limited Liability Company Act (805 ILCS 180/1-1 et seq.); or
- vi. a business organized under the Professional Limited Liability Company Act (805 ILCS 185/1 et seq.);

- vii. A joint venture in which each joint venturer satisfies one of the qualifications of i – vi above.
- c. Notice Of Intent To Match Low Bid. If the lowest responsive, responsible bidder is not a qualified Illinois bidder and if a qualified Illinois bidder has submitted a bid which is within four percent (4%) of the lowest responsive, responsible bidder for an item or bid, the qualified Illinois bidder shall be given written notice to that effect and may, within five (5) days from the date of such notice, provide written confirmation to the Commission that it will match the bid price of the lowest responsive, responsible bidder. The qualified Illinois bidder shall, where the bid is an aggregate of separate price components, reduce the price of each separate component of its aggregate bid by the same percentage that was used to match the bid of the lowest responsive, responsible bidder. If a qualified Illinois bidder fails to provide such written confirmation within the time allowed, its bid shall be considered as originally submitted.

- d. Multiple Qualified Illinois bidders. If more than one qualified Illinois bidder is within four percent (4%) of the lowest responsive, responsible bidder, only the qualified Illinois bidder submitting the lowest bid shall be given the opportunity to match the bid of the lowest responsive, responsible bidder. The qualified Illinois bidder shall, where the bid is an aggregate of separate price components, reduce the price of each separate component of its aggregate bid by the same percentage that was used to match the bid of the lowest responsive, responsible bidder.
- e. Rejection of Bids. The Commission may reject any and all bids and award the contract to a bidder other than the lowest responsive, responsible bidder or a qualified Illinois bidder who matches the lowest responsible bid upon the determination of the Commission that it is in the Authority's best interests to do so.
- f. Certification. A bidder shall certify in its bid or proposal whether it is a qualified Illinois bidder under this Code.

- c. Subsequent Awards. Contracts awarded to a bidder who fails to comply with all conditions precedent to formal execution of the contract agreement may be annulled. Upon annulment of an award, the Commission may award the contract to any other bidder whose proposal is found to be in the best interests of the Commission in accordance with Subsection 11(b) above, or the Commission may advertise anew for bids.

Section 12: Single Bids. The Board of Commissioners desires competitive bids; however, where there is only one bid, that fact alone shall not prevent the Commission from accepting that bid.

Section 13: Performance and Payment Bonds. The Commission may require a performance bond before entering a contract in such amount as it shall find reasonably necessary to protect the best interests of the Commission. The Commission shall require a payment bond in such amount as it shall find reasonably necessary to secure payment for material used and labor performed in connection with a public work.

Section 14: Change Orders. All contract change orders shall be considered and approved or disapproved by the Commission during the regular course of its conduct of business except in the following circumstances.

- a. By General Manager. The General Manager shall have the authority to approve any contract change order:
 - (i) based entirely upon approved unit prices; or
 - (ii) In an amount not in excess of \$100,000 when in the judgment of the General Manager and the

Commission's consulting engineer such change order requires immediate approval to avoid significant impacts to the project schedule or the incurring of unnecessary and excessive costs by the Commission.

A full written description and explanation of any change order so approved by the General Manager shall be distributed to the Board of Commissioners as soon as possible following its approval.

- b. By Commission at Special or Emergency Meeting. When in the judgment of the General Manager a change order in an amount in excess of \$100,000 requires a more immediate approval than the Commission's regular meeting schedule would permit in order to avoid the incurring of significant impacts to the project schedule or unnecessary and excessive costs by the Commission, or when, in any other case, in the judgment of the General Manager a change order requires the immediate attention of the Commission, the General Manager may call a special or emergency meeting of the Commission for the consideration of such change order.

Section 15: Prohibition Against Subdivision. No contract or change order shall be subdivided to avoid the requirements of these By-Laws. This prohibition shall not prevent the repetitive purchase of supplies, material or work which is purchased over a period of time as needed.

Section 16: Emergencies. In case of an apparent emergency which requires immediate purchase of supplies, material or work to protect persons or property, the

General Manager shall be authorized to secure any supplies, material or work necessary to address such emergency by whatever means deemed necessary without regard to the procedures otherwise required under these By-Laws. A full written description and explanation of any such emergency purchase shall be distributed to the Board of Commissioners as soon as possible following the emergency.

Section 17: Bid Item Must Be Budgeted. Contracts or purchase orders cannot be executed and are invalid and void unless the amounts due there under have been budgeted by the Board of Commissioners.

Section 18: Cooperative Purchasing Arrangements. Nothing in this Article VIII shall be interpreted to prohibit the Commission from participating with other public bodies, associations or agencies, or with other units of government, in any cooperative purchasing arrangements subject to bidding or other processes that assure the protection of the best interests of the Commission. Supplies, materials or work purchased through such arrangement shall be exempted from the requirements of this Article.



Resolution #: R-55-24

Account: N/A

Approvals: *Author / Manager / Finance / Admin*

D.P. RCB CAP PDM

REQUEST FOR BOARD ACTION

Date: 10/10/2024

Description: A Resolution Authorizing and Ratifying the Disposal of Certain Personal Property Owned by the DuPage Water Commission

Agenda Section: Administration Committee

Originating Department: Pipeline & Remote Facilities

Resolution No. R-55-24 is a Resolution Authorizing and Ratifying the Disposal of Certain Personal Property Owned by the DuPage Water Commission. This Resolution authorizes the General Manager to dispose of the assets listed on Exhibit A to the Resolution in compliance with the DuPage Water Commission's Vehicle Replacement Policy as these assets are beyond their useful life cycle, repair or refurbishment cost is prohibitive, and these assets are no longer useful to the Commission.

The vehicle listed in Exhibit A will be listed up for auction at Obenauf Auction Service, Inc., an open to the public Government and Municipal Auction house serving the Midwest, Northern Illinois and Southern Wisconsin.

Obenauf Auction Service, Inc.
810 Magna Drive
Round Lake, IL. 60073
847-546-2095

Estimated auction value of the 2017 Ford F150 is approximately \$3,500.

Recommended Motion:

Adopt R-55-24, A Resolution Authorizing and Ratifying the Disposal of Certain Personal Property Owned by the DuPage Water Commission.

EXHIBIT A

Qty	Serial Number	Description	Details
1	1FTFX1EFpHKD76611	2017 Ford F150 XLT Pick-Up with 101,417 miles	<ul style="list-style-type: none">• Exceeds 100,000 miles and exceeds useful life.• Slated for replacement in FY-24/25 Management Budget

RESOLUTION NO. R-55-24

**A RESOLUTION AUTHORIZING AND RATIFYING
THE DISPOSAL OF CERTAIN PERSONAL PROPERTY OWNED BY THE
DUPAGE WATER COMMISSION**

WHEREAS, the DuPage Water Commission is authorized to sell or otherwise dispose of personal property pursuant to 65 ILCS 5/11-135-6; and

WHEREAS, in the opinion of the Board of Commissioners of the DuPage Water Commission, the personal property described in Exhibit A attached hereto and by this reference incorporated herein and made a part hereof (the "Property") is no longer necessary or useful to or for the best interests of the DuPage Water Commission to retain or, if already disposed of, was not necessary or useful to or for the best interests of the DuPage Water Commission to retain;

NOW, THEREFORE, BE IT RESOLVED by the Board of Commissioners of the DuPage Water Commission as follows:

SECTION ONE: The Board of Commissioners of the DuPage Water Commission hereby finds and determines that the Property is no longer necessary or useful to the DuPage Water Commission and the best interests of the DuPage Water Commission will be served by its disposal or, if already disposed of, was not necessary or useful to the DuPage Water Commission and the best interests of the DuPage Water Commission were served by its disposal.

SECTION TWO The General Manager is hereby authorized to dispose of the Property in such manner as the General Manager shall determine or, if already disposed of, the Board of Commissioners of the DuPage Water Commission hereby ratifies and confirms its disposal.

SECTION THREE: This Resolution shall be in full force and effect from and after its adoption.

	Aye	Nay	Absent	Abstain
Bouckaert, D.				
Cuzzone, N.				
Fennell, J.				
VACANT	XXXXXXXXXXXXXXXXXXXXXXXXXXXX			
Novotny, D.				
Pruyn, J.				
Romano, K.				
Rush, K.				
Russo, D.				
Saverino, F.				
Suess, P.				
Van Vooren, D.				
Zay, J.				

ADOPTED THIS ___ DAY OF _____, 2024.

James F. Zay, Chairman

ATTEST:

Danna Mundall, Clerk



Resolution #: R-58-24

Account: 01-60-62800 \$16,000

Approvals: *Author / Manager / Finance / Admin*

RCB RCB CAP PDM

REQUEST FOR BOARD ACTION

Date: 10/10/2024

Description: **A Resolution Retaining SPI Energy Group for Retail Electric Supply Market Consulting Services**

Agenda Section: Administration Committee

Originating Department: Operations & Instrumentation

SPI Energy Group is an energy market consultant that has been providing consulting services to the Commission in connection with the selection of an alternative electrical suppliers and the successful negotiation of the electrical supply agreements since 1997. Staff desires to continue to retain the services of SPI Energy Group on an as-needed basis in connection with negotiating for the Commission's electrical supply needs prior to the existing contract expiration on April 3, 2025.

SPI Energy Group will seek out potential suppliers for the Illinois market, engage with each to procure their proposals to provide the most efficient and cost beneficial commodity pricing and then bring forth these pricing proposals for evaluation and recommendations to the Board to provide the electrical commodity for the DuPage Pump Station.

The SPI Energy Group hourly rate is \$250/hour with an estimated expense not-to-exceed \$16,000 to receive alternative pricing from qualified alternate retail electrical service providers, perform pricing analysis of all proposals received, and engage in contract negotiations on behalf of the Commission when instructed to do so by the General Manager.

Recommended Motion:

Approve R-58-24, a resolution to retain the services of SPI Energy Group for Retail Electric Supply Market Consulting Services.

DUPAGE WATER COMMISSION

RESOLUTION NO. R-58-24

A RESOLUTION RETAINING SPI ENERGY GROUP
FOR ILLINOIS ELECTRIC MARKET CONSULTING SERVICES

WHEREAS, the Illinois Electric Service Customer Choice and Rate Relief Law (the “Law”) was enacted in December 1997 and deregulated the electrical industry; and

WHEREAS, as allowed by the Law, the Commission entered into an electrical supply agreement with a retail electric supplier, which electrical supply agreement will expire on or about April 3, 2025; and

WHEREAS, before extending the existing electrical energy supply agreement, the Commission would like to ensure that it will receive power and possibly other services at current or better market rates, terms and conditions; and

WHEREAS, the Commission would also like to retain electric market consulting services as needed in the future due to developments in the Illinois electric supply market; and

WHEREAS, SPI Energy Group is a consulting firm consisting of experienced electrical professionals with utility experience; and

WHEREAS, SPI Energy Group has provided outstanding Illinois electric market consulting services to the Commission since 1997, including consulting services in connection with the Commission’s selection of the alternative electrical suppliers and the negotiation of the existing electrical supply agreement; and

WHEREAS, the Commission desires to obtain, and SPI Energy Group, desires to provide, Illinois electric market consulting services in connection with the extension of the existing electrical supply agreement and as needed in the future due to developments in the Illinois electric supply market;

NOW, THEREFORE, BE IT RESOLVED by the Board of Commissioners of the DuPage Water Commission as follows:

SECTION ONE: The foregoing recitals are hereby incorporated herein and made a part hereof as findings of the Board of Commissioners of the DuPage Water Commission.

SECTION TWO: The DuPage Water Commission hereby retains SPI Energy Group to provide Illinois electric market consulting services in connection with the extension of the Commission’s existing electrical supply agreement and as needed in the future due to developments in the Illinois electric supply market, subject to a maximum total expenditure of \$16,000 in Fiscal Year 2024-2025.

SECTION THREE: This Resolution shall be in full force and effect from and after its adoption.

	Aye	Nay	Absent	Abstain
Bouckaert, D.				
Cuzzone, N.				
Fennell, J.				
VACANT	[REDACTED]			
Novotny, D.				
Pruyn, J.				
Romano, K.				
Rush, K.				
Russo, D.				
Saverino, F.				
Suess, P.				
Van Vooren, D.				
Zay, J.				

ADOPTED THIS _____ DAY OF _____, 2023.

James F. Zay, Chairman

ATTEST:

Danna Mundall, Clerk
Board/Resolutions/2024/R-58-24.docx

EXHIBIT 1

DELETE PAGE IF NO ATTACHMENT



*providing electric and natural gas procurement and regulated ratemaking
expertise and advice to clients since 1996*

2621 MONTEGA DRIVE
SUITE D
SPRINGFIELD, ILLINOIS 62704
(217) 241-5388

SPI Energy Group

Electric and Natural Gas marketers are reaching out to consumers and offering them various new products for their energy dollar. As the industry becomes more and more complex, consumers will look for ways to adapt to, and take advantage of, the electric and natural gas marketplaces.

That's why SPI Energy Group was created.

SPI Energy Group is a consulting firm consisting of gas and electric utility professionals, with decades of utility experience. We have extensive knowledge of the electric and gas markets, but do not own or sell energy, capacity, energy management systems, or engineering services. Likewise, we do not take financial positions in electric or gas markets, we do not have any vested interest in power or natural gas suppliers. As a result, we will direct bill you for our consulting fees. Our purpose is simply to advise clients on their best course of action regarding energy markets.

Energy Consulting Services

Pricing strategies, regulation, and utility costing, contracts and service options are just a few of the issues that impact your energy future. In an effort to provide value to clients, SPI Energy Group uses its expertise to advise:

- **utility companies, including cooperative and municipal systems, who want to market their services**
- **parties with interest in legislative initiatives for opening of utility markets**

SPI Energy Group can assist with:

- **existing electric and natural gas marketplaces to take full advantage for your costs**
- **regulation and utility costing**
- **electric and natural gas service offerings**
- **management of utility restructuring issues**
- **contracts and customer service options**

1 **Direct Testimony of James G. Bachman**

2 **On Behalf of**

3 **Northeast Illinois Regional Commuter Railroad Corporation, d/b/a Metra and**
4 **Chicago Transit Authority**

5
6
7
8 **Q. PLEASE STATE YOUR NAME, TITLE, EMPLOYER AND BUSINESS**
9 **ADDRESS.**

10 **A.** James G. Bachman, Partner, SPI Energy Group, 2621 Montega Drive, Springfield,
11 Illinois 62704

12 **Q. ON WHOSE BEHALF ARE YOU TESTIFYING IN THIS PROCEEDING?**

13 **A.** I am testifying on behalf of the Northeast Illinois Regional Commuter Railroad
14 Corporation d/b/a Metra ("Metra") and the Chicago Transit Authority ("CTA").

15 **Q. PLEASE DESCRIBE YOUR PROFESSIONAL EXPERIENCE.**

16 **A.** I have worked in the electric and natural gas industry for forty-three years. For the last
17 seventeen years I have been a Partner in SPI Energy Group. SPI Energy Group is an electric and
18 natural gas consulting firm. We assist clients (retail end users of electricity and natural gas) in
19 understanding and purchasing energy from the electric and natural gas marketplaces as end users.
20 In addition, SPI Energy Group has assisted clients with their regulatory issues and requirements
21 before the Illinois Commerce Commission. For the nineteen years prior to my work for SPI
22 Energy Group, I was employed by Central Illinois Public Service Company ("CIPS") in several
23 administrative and executive positions including Vice-President of Marketing, Vice-President of

24 Corporate Planning and Manager of the Rates and Regulatory Department. I had responsibility
25 for cost of service studies, rate design and rate policy for CIPS from 1980 through 1992. Prior to
26 my employment at CIPS, I held several staff positions with Wisconsin Electric Power Company
27 where I started my electric and natural gas career in 1970.

28 **Q. WHAT IS YOUR EDUCATIONAL BACKGROUND?**

29 **A.** I received a Bachelor of Arts degree in Economics from the University of Wisconsin-
30 Madison in 1970. I received a Master of Business Administration degree from the University of
31 Illinois-Champaign/Urbana in 1990. A copy of my resume is attached as CTA/Metra Joint
32 Exhibit 1.01.

33 **Q. HAVE YOU PREVIOUSLY TESTIFIED BEFORE THE ILLINOIS COMMERCE**
34 **COMMISSION ("ICC" OR "COMMISSION") AND THE FEDERAL ENERGY**
35 **REGULATORY COMMISSION ("FERC")?**

36 **A.** Yes, I testified before the ICC and FERC in every CIPS rate case docket from 1977
37 through 1992 before the two regulatory agencies. I also testified for CTA and Metra in ComEd
38 cases, ICC Docket Nos. 07-0566, 08-0532, 09-0263, 09-0407, 10-0467, 10-0527 and 11-0721.

39 **Q. WHAT IS THE PURPOSE OF YOUR TESTIMONY?**

40 **A.** My testimony addresses service and Embedded Cost of Service Study (ECOSS) issues as these
41 issues relate to the Railroad Delivery Class. In its filing ComEd presents several ECOSS that include cost
42 allocation impacts on the Railroad Delivery Class's revenue requirement. Those areas and the Railroad
43 Delivery Class's response are summarized as follows:

44 • ComEd presents ComEd Exhibit 3.01 as the ECOSS that is the basis for the Rate
45 Design Investigation (RDI) for its filing in this Docket. This ECOSS that ComEd
46 designates as the RDI ECOSS fails to account for the Commission directive to

CTA/Metra Joint Exhibit 1.01

JAMES G. BACHMAN

WORK EXPERIENCE

SPI Energy Group Inc.
Springfield, Illinois

Partner and Founder

July 1996 to present

Set up consulting firm with partners and developed client base to provide consultant services related to gas and electric markets. Advising utility and power supplier clients on getting into competitive marketplace. Representation of utility clients before Illinois, Missouri and Virginia regulatory commissions. Advising commercial and industrial clients on lower cost basis for utility bills. Services include contract negotiations, strategic planning, RFP processing and regulatory representation.

Central Illinois Public Service Company and CIPSCO Investment Company
Springfield, Illinois

Vice President, Marketing

December 1994 - July 1996

Administrative and policy responsibility for Company's marketing function, including responsibility for bringing organization together and development of Corporate Marketing Plan consistent with Corporate strategic goals. The Marketing Team is made up of four areas: Customer Expansion and Retention, Marketing Programs, Wholesale Marketing and Marketing Services. Member of several corporate committees, including Strategic Planning, Business Process Re-engineering, Executive Committee and Wage and Salary.

Vice President and Chief Operating Officer

February 1993 - February 1995 (half-time)

(CIPSCO Investment Company)

Was responsible for generation and development of new investment approaches and ideas for Company's non-regulated investment subsidiary. Worked as a close-knit team with CFO and Vice President-Investments to revamp CIC passive investments and responsibility for setting up CIPSCO Venture Company.

Vice President, Corporate Planning

August 1989 - December 1994

Administrative responsibility for Rates and Research and Corporate Planning Departments which had functional control over regulatory affairs, rate administration, customer research, economic cost analysis, demand and energy forecasting, service area econometric forecasting and financial model forecasting. Coordinated the Corporate Strategic Planning effort for the CEO and responsible for production of Corporate Strategic Plan. Lead policy witness in several regulatory proceedings before both the Illinois Commerce Commission and Federal Energy Regulatory

Commission and testified before several legislative committees. Chaired three "ad hoc" marketing teams from December 1993 through December 1994.

Manager, Rates and Research Department February 1980 - August 1989
Functional and technical responsibility for regulatory liaison, rate administration, cost of service, customer research and regulatory case coordination. Was lead technical witness in several cases before the Illinois Commerce Commission and Federal Energy Regulatory Commission. Corporate liaison and coordinator in anti-trust litigation that was filed against CIPS.

Supervisor and Staff Positions in Rates & Research Department June 1977 - February 1980
Technical responsibility for cost of service rate design and customer research.

Wisconsin Electric Power Company

Milwaukee, WI

June 1970 - June 1977

- Various training and staff positions, involving cost analysis, cost of service and rate design.

EDUCATION

- Master of Business Administration, University of Illinois
- Bachelor of Arts, Economics, University of Wisconsin
- Public Utility Executive Program, University of Michigan

PUBLIC APPEARANCES

- Guest lecturer at several colleges and universities
- Participated in radio and TV interviews
- Guest speaker at civic groups in central and southern Illinois



DuPage Water Commission
Power Supply RFP Process
For Contract to Begin April 2025
Schedule and Budget

- A. Plan for Initial Pricing
 - 1. Alternative terms of :
 - i. 12 months
 - ii. 24 months
 - iii. 36 months
 - 2. Inform Power Suppliers
 - i. Pricing request including terms and contacting party
 - ii. Initial pricing alternatives due October 17th
 - 3. Initial Pricing Analysis
 - i. Develop pricing comparison and conclusions
 - ii. Presentation to DPWC team before October 30th
 - a. Budget Estimate:
 - 8 to 10 hours
 - \$2,000 to \$2,500
- B. Based on Presentation Discussion, moving forward with additional prices from Power Suppliers
 - 1. Each month the Power Supplier Pricing analysis is extended
 - i. Develop pricing comparison and conclusions on predetermined basis
 - ii. Presentation to DPWC team, as needed
 - a. Budget Estimate for each month extended:
 - 5 to 10 hours
 - \$1,250 to \$2,500
 - Maximum 4 months
- C. Contract Discussions for Power Supply
 - 1. Will be bridge between Power Supplier and DPWC
 - 2. See the Contract through to conclusion and signing
 - 3. Whenever pricing is agreed to. However, no later than first week in March 2025.
 - a. Budget Estimate:
 - 10 to 14 hours
 - \$2,500 to \$3,500
- D. Budget Estimate Range
 - 1. Minimum Budget estimate \$4,500
 - 2. Maximum Budget Estimate \$16,000
 - 3. You never get billed for travel
 - i. It is as if our office is right next to yours.



Resolution #: R-60-24, R-61-24, R-62-24, R-63-24, R-64-24, and R-65-24

Account: N/A

Approvals: *Author / Manager / Finance / Admin*

REQUEST FOR BOARD ACTION

Date: 10/9/2024

Description: **Recommendation to Approve Water Purchase and Sales Agreement(s) and Capital Cost Recovery Charge Agreement(s) for the WaterLink communities of Oswego, Yorkville, and Montgomery**

Agenda Section: Administration Committee

Originating Department: Administration

I am pleased to present the WaterLink Customer Agreements for DWC Board consideration. The WaterLink communities have been working toward a new water source for over 10 years after becoming aware of impending water scarcity in the aquifer which provides their current supply. After extended study, the WaterLink partners (Oswego, Montgomery, and Yorkville), identified Lake Michigan source water delivered by the DuPage Water Commission as the preferred future source. This project will be one of the largest water projects in the Midwest, and will extend the DWC service area into Kendall counties with DWC water transmission infrastructure extending west of the Fox River upon completion.

The WaterLink communities have received IDNR allocations and have worked with DWC to fund Phase I and Phase II engineering over the last two years. During this period of time, the WaterLink communities have also been preparing financing instruments to fund the construction of the new infrastructure necessary to be constructed by DWC to convey water to the WaterLink communities. All project costs, including legal, engineering, property acquisition, construction, and commissioning will be funded by the WaterLink communities through a WaterLink Connection Facilities Agreement (R-66-24) and companion Project Escrow agreement (R-67-24), also included on this agenda.

The contract documents presented for approval have been crafted to provide continuity with previously approved Subsequent Customer Agreements to the greatest extent possible. DWC Legal Counsel and staff have worked closely with the WaterLink communities, their staff, and their legal counsel over many months to advance these documents for consideration. I wish to acknowledge and thank them for the significant effort that was provided to complete this task.

A summary of the primary elements of the Agreements is provided following:

Water Purchase and Sales Agreements (R-60-24, R-62-24, R-64-24):

The Water Purchase and Sale Agreement(s) have been constructed to provide a term that matches that of the other Contract Customers, ending February 24, 2064; and include language, terms, and conditions consistent with DWC Contract Customers. The project is scheduled for construction to commence in 2025 and to be commissioned in 2028. WaterLink communities will begin to access the new water source at that time, or as soon as permitted based upon achieving compliance with the IDNR water loss regulations.

Capital Cost Recovery Charge Agreements (R-61-24, R-63-24, R-65-24):

All new (subsequent) DWC customers are required to provide a Capital Cost Recovery Charge (aka “buy-in fee”) to ensure parity with the original Charter Customers which paid for the original DWC system upon formation. The Capital Cost Recovery Charged is determined by computing each customer’s pro-rata share by utilizing their IDNR allocation to calculate their demand as a percentage of the whole, and multiplying that percentage by the value of all DWC fixed assets as of the most recently audited fiscal year (FYE 2024). Based upon these computations, the Capital Cost Recovery Charges to be collected are as follows:

Oswego:	\$11,047,790
Montgomery:	\$ 9,998,815
Yorkville:	\$ 8,013,886

Companion Agreements:

In addition to the 1) Water Purchase and Sale Contract(s) and 2) Capital Cost Recovery Charge Agreement(s) for each of three WaterLink Communities, there are also two additional agreements for which there are four parties/signatories: the Village of Oswego, the Village of Montgomery, the United City of Yorkville, and the DuPage Water Commission. These items are included on the DWC October 17, 2024 DWC Agenda and are listed below:

- Resolution R-66-24: WaterLink Connection Facilities Intergovernmental Agreement
- Resolution R-67-24: WaterLink Project Escrow Agreement

Recommended Motion:

It is recommended that the DWC Board approve the Water Purchase and Sales Agreement(s) and the Capital Cost Recovery Charge Agreement(s) for the WaterLink communities of Oswego, Montgomery, and Yorkville.

DUPAGE WATER COMMISSION

RESOLUTION NO. R-60-24

A RESOLUTION APPROVING A WATER PURCHASE AND SALE CONTRACT
WITH THE VILLAGE OF OSWEGO

WHEREAS, the Commission was formed and exists pursuant to the Water Commission Act of 1985, 70 ILCS 3720/0.01 et seq., and Division 135 of Article 11 of the Illinois Municipal Code, 65 ILCS 5/11-135-1 et seq., for the purpose of securing an adequate source and supply of water for its customers; and

WHEREAS, the Village of Montgomery (“Montgomery”), the Village of Oswego (“Oswego”) and the United City of Yorkville (“Yorkville”) (collectively the “Municipalities”) desire to supply Lake Michigan water to their residents by connecting to the Commission’s waterworks system (the “Project”); and

WHEREAS, the Commission and Oswego have negotiated an Intergovernmental Agreement Concerning Capital Cost Recovery Charge and a Water Purchase and Sale Contract for the Project; and

WHEREAS, concurrently with the enactment of this Resolution, the Commission and the Municipalities are entering into an Intergovernmental Agreement Concerning Development of Connection Facilities to Implement Water Service for the Project; and

WHEREAS, concurrently with the enactment of this Resolution, the Commission and the Municipalities are entering into a WaterLink Project Escrow Intergovernmental Agreement with the Municipalities for the Project; and

WHEREAS, the Commission deems it to be in the best interests of the Commission and the public to complete the Project and enter into the Water Purchase and Sale Contract with Oswego.

NOW, THEREFORE, BE IT RESOLVED by the Board of Commissioners of the DuPage Water Commission as follows:

SECTION ONE: The Board of Commissioners of the DuPage Water Commission hereby approves the Water Purchase and Sale Contract with the Village of Oswego attached hereto as Exhibit 1 and

authorizes the Chairman to execute the Water Purchase and Sale Contract on behalf of the DuPage Water Commission and to take whatever steps necessary to effectuate the terms of said agreement.

SECTION TWO: This Resolution shall be in full force and effect after passage and approval as required by law.

	Aye	Nay	Absent	Abstain
Bouckaert, D.				
Cuzzone, N.				
Fennell, J.				
VACANT	_____			
Novotny, D.				
Pruyn, J.				
Romano, K.				
Rush, K.				
Russo, D.				
Saverino, F.				
Suess, P.				
Van Vooren, D.				
Zay, J.				

ADOPTED THIS _____ DAY OF _____, 2024.

James F. Zay, Chairman

ATTEST:

Danna Mundall, Clerk

Board/Resolutions/2024/R-60-24.docx

EXHIBIT 1

DUPAGE WATER COMMISSION

WATER PURCHASE AND SALE CONTRACT

Between

The DuPage Water Commission

and

The Village of Oswego

FOR THE VILLAGE OF OSWEGO UNIT SYSTEM

October 17, 2024

**DUPAGE WATER COMMISSION
WATER PURCHASE AND SALE CONTRACT
WITH THE VILLAGE OF OSWEGO**

Table of Contents

	Page
SECTION 1. PREAMBLES	5
SECTION 2. DEFINITIONS.....	5
SECTION 3. WATER SUPPLY.....	16
A. Agreement to Sell and Purchase	16
B. Beginning of Obligations to Deliver and Receive Lake Water	16
C. Limits on Supply	17
D. Emergency or Maintenance Turn-Off	17
E. Curtailment; Emergency Use of Other Sources	17
F. Water Quality	18
SECTION 4. DELIVERY; STORAGE	19
A. Oswego Unit System Connection Facilities	19
B. Storage	20
C. Metering of Shallow Wells.....	21
D. Surges and Back-Flows	21
E. Maintenance of System; Water Quality; Prevention of Waste.....	21
SECTION 5. MEASURING EQUIPMENT	22
A. Metering Station and Instrumentation	22
B. Records	23
C. Calibration	24
D. Check Meters	24
E. Meter Malfunctions.....	25
F. Removal of Metering Station and SCADA System Facilities	26
SECTION 6. UNIT OF MEASUREMENT	26
SECTION 7. PRICES AND TERMS OF PAYMENT	26
A. Operation and Maintenance Costs Payment	26
B. Fixed Costs Payment	27
C. Connection Facilities Cost Payment.....	29
D. Capital Cost Recovery Charge Payment.....	29
E. Underconsumption Costs Payment.....	30

	Page
F. Default Shares	31
G. Bills and Due Date	31
H. Disputed Payments.....	32
I. Interest on Overdue Payments	33
J. Security Deposit.....	34
K. Prepayments.....	35
L. Enforcement of Provisions Hereof by Other Customers	36
M. Beginning of Obligation to Pay	37
 SECTION 8. SPECIAL CONDITIONS AND COVENANTS	 38
A. Construction of the Commission Connection Facilities; No Delay Damages; Supply of Lake Water	 38
B. Lake Water Only; Costs.....	39
C. Title to Lake Water	39
D. Emergency Supply	39
E. Covenants to Be Set Out in Bond Ordinance.....	39
F. Payments Hereunder are an Operational Expense of the Oswego Unit System.....	 40
 SECTION 9. ADDITIONAL OSWEGO COVENANTS.....	 41
A. Maintenance of Corporate Existence	41
B. Maintenance and Operation of Oswego Unit System.....	41
C. Rate Covenant	41
D. Future Subordination of Obligations	42
E. General Covenant to Operate Properly	43
F. Accounting and Audit.....	43
G. Maintain Ownership of Oswego Unit System	43
H. Insurance.....	44
I. Continue to Serve.....	44
J. Maintain Water Allocation	44
K. Release and Indemnification.....	44
L. Combining or Separating System Accounts	45
M. Rate of Withdrawal	46
N. Emergency Interconnections.....	46
 SECTION 10. SCHEDULE FOR COMPLETION OF VARIOUS FACILITIES	 49
A. Plans and Specifications for Oswego Unit System Connection Facilities	 49
B. IEPA and Other Approvals For Oswego Unit System Connection Facilities	49

	Page
C. Commencement of Construction of Oswego Unit System Connection Facilities	50
D. Intentionally Omitted.....	50
E. Intentionally Omitted.....	50
F. Intentionally Omitted.....	50
G. Transfer of Property Rights	50
H. Commencement of Construction of Commission Connection Facilities	50
I. Delivery of Water for Start-Up Purposes	51
J. Illustrative Schedule of Events	52
SECTION 11. ASSIGNABILITY.....	52
SECTION 12. FORCE MAJEURE	53
SECTION 13. COMMISSION DEFAULTS	54
SECTION 14. OSWEGO OBLIGATION UNCONDITIONAL.	55
SECTION 15. COOPERATION IN CONSTRUCTION; EASEMENTS.....	56
SECTION 16. COOPERATION IN ISSUANCE OF BONDS	56
SECTION 17. REGULATORY BODIES	57
SECTION 18. OTHER WATER SUPPLIERS.	58
SECTION 19. NOTICES; EVIDENCE OF ACTIONS; WAIVER.....	58
A. Notices	58
B. Evidence of Actions	58
C. Waiver	59
D. Partial Invalidity	59
SECTION 20. EFFECTIVE DATE; TERMINATION; PAYMENT OF INTERIM COSTS; TERM	59
A. Effective Date	59
B. Commission Right to Terminate	60
C. Payment of Interim Costs	60
D. Term	61
SECTION 21. GOVERNING LAW AND VENUE.....	61
SECTION 22. MUNICIPAL BOUNDARIES.....	62

	Page
SECTION 23. MODIFICATIONS OR AMENDMENTS	62
SECTION 24. EXHIBITS INCORPORATED.....	62
SECTION 25. EXECUTION IN COUNTERPARTS	62

**DUPAGE WATER COMMISSION
WATER PURCHASE AND SALE CONTRACT WITH THE VILLAGE
OSWEGO
FOR THE VILLAGE OF OSWEGO UNIT SYSTEM**

This Water Purchase and Sale Contract (“Contract”), dated as of October 17, 2024, by and between the **DUPAGE WATER COMMISSION**, DuPage, Cook, and Will Counties, State of Illinois (the “Commission”), a county water commission and public corporation under Division 135 of Article 11 of the Illinois Municipal Code, 65 ILCS 5/11-135-1 *et seq.*, and the Water Commission Act of 1985, 70 ILCS 3720/1 *et seq.* (collectively, the “Acts”), and the **VILLAGE OF OSWEGO**, Kendall and Will Counties, Illinois, a municipal corporation duly organized and existing under the laws of the State of Illinois (“Oswego”);

WITNESSETH:

WHEREAS, the Commission has been organized under the Acts to supply water within its territorial limits; and

WHEREAS, the Commission owns and maintains a waterworks system as a supplier of Lake Michigan water to member customers that contract for such service; and

WHEREAS, Oswego currently owns and operates a municipal drinking water system served by wells that extract source water from the Ironton-Galesville aquifer; and

WHEREAS, Oswego is within the territorial limits of the Commission; and

WHEREAS, Oswego, together with the Village of Montgomery and the United City of Yorkville (collectively the “WaterLink Communities”), conducted extensive

study and concluded that the most sustainable alternative water source to serve the WaterLink Communities through the municipal waterworks systems currently serving the WaterLink Communities, as well as any extensions or improvements of those systems is Lake Michigan water from the Commission; and

WHEREAS, Oswego (along with the WaterLink Communities) has applied for and received from the State of Illinois Department of Natural Resources, Office of Water Resources, a Lake Michigan water allocation permit for the Oswego Unit System; and

WHEREAS, Oswego is in the process of designing and constructing the conversion of its waterworks system that will be owned and operated by Oswego and extended or improved from time to time to meet the potable water requirements of all residents and businesses to be served with water from Oswego, which waterworks system is preliminarily depicted in Exhibit A attached to this Contract; and

WHEREAS, the Commission and the WaterLink Communities have entered into Escrow Agreements and have been taking steps to finance, study, engineer, design, and construct the facilities necessary for the WaterLink Communities to receive Lake Michigan water, and the Commission has been taking steps to study, finance, engineer, design, and construct the Commission Connection Facilities (as defined herein) to deliver Lake Michigan water to the WaterLink Communities; and

WHEREAS, contemporaneously with this Agreement, the WaterLink Communities and the Commission are entering into a WaterLink Project Escrow Intergovernmental Agreement, an Intergovernmental Agreement with the Village of Oswego Concerning Capital Cost Recovery Charge, and an Intergovernmental

Agreement Concerning Development of Connection Facilities to Implement Water Service; and

WHEREAS, the WaterLink Communities have started Optimal Corrosion Control Treatment (OCCT) Studies of their water systems to be filed with the Illinois Environmental Protection Agency. The Commission and Oswego acknowledge that the OCCT Study, including recommendations for infrastructure improvements that may be needed as a result of recommendations for optimized corrosion control treatment, will not be completed and reviewed by IEPA until approximately October 2025; and

WHEREAS, Oswego and the Commission recognize that construction may begin pending the results of the OCCT Study; and

WHEREAS, Oswego desires that its waterworks system preliminarily depicted in Exhibit A attached to this Contract as well as any extensions or improvements of that system (the “Oswego Unit System”) be served with water from the Commission beginning sometime in 2028 as mutually agreed to by the parties; and

WHEREAS, the Commission has entered various water supply contracts with the City of Chicago to purchase Lake Michigan water sufficient to meet the water supply needs of the Commission and its customers (the “Water Supply Contract”) and most recently in 2024 and extends until 2041; and

WHEREAS, at some point during the term of this Contract, the Commission may build alone or with others a water treatment, distribution, and transmission system to obtain Lake Michigan water directly from Lake Michigan that will serve the

Commission; and

WHEREAS, the Commission has issued and sold and may further propose to issue and sell Bonds (as defined in Section 2 below) from time to time during the term of this Contract in sufficient amounts for the payment of the costs of its project of acquiring, designing, constructing, and maintaining its Waterworks System (as defined in Section 2 below); and

WHEREAS, such Bonds have been and may be issued in the future from time to time by the Commission pursuant to Bond Ordinances (as defined in Section 2 below) adopted by the Commission; and

WHEREAS, pursuant to the Acts, Article VII, Section 10 of the Illinois Constitution of 1970, the Intergovernmental Cooperation Act, 5 ILCS 220/1 *et seq.*, and the Public Utilities Act, 220 ILCS 5/1 *et seq.* as amended, the Commission and Oswego are authorized to enter into this Contract; and

WHEREAS, by the execution of this Contract, Oswego is surrendering none of its rights to the ownership and operation of the Oswego Unit System, except as expressly provided for, and only to the limited extent so provided for, in this Contract, and Commission is surrendering none of its rights to the ownership and operation of its Waterworks System, but each asserts its continued right to operate such systems; and

WHEREAS, Oswego recognizes that the Commission may use this Contract as the basis, in part, for obtaining loans from time to time to be evidenced by the issuance of its Bonds; and for payment of the principal of and the premium, if any, and interest on such Bonds; and as the means for the payment of its maintenance and operating

expenses; and for such purposes as may be authorized by applicable statutes or required in any Bond Ordinance adopted by the Commission authorizing issuance of Bonds; and

WHEREAS, Oswego recognizes that the Commission may in the future enter into contracts with other customers that are members of or may join the Commission.

NOW, THEREFORE, in consideration of the foregoing recitals and of the mutual covenants and agreements herein contained, the Commission and Oswego hereby agree as follows:

SECTION 1. PREAMBLES.

The preambles hereto are hereby incorporated herein by this reference and are made fully a part of this Contract.

SECTION 2. DEFINITIONS.

The following words and phrases shall have the following meanings when used in this Contract.

A. "Aggregate Costs" means Operation and Maintenance Costs, Fixed Costs, and Underconsumption Costs, collectively, as defined herein.

B. "Alternate Delivery" means the delivery of Lake Water purchased by Oswego from the Commission to the Oswego Unit System through facilities owned by a Contract Customer (commonly referred to as "Wheeling").

C. "Asset-In-Kind Amount" means the differential amount, if any, that Oswego pays for a portion of the increase in size of the primary 48" western pipeline (commencing at Book Road and 75th Street and extending west of the Fox River to a termination point at Orchard Road, also known as "TW 6/25" in the DWC naming convention)

from the baseline pipe size to 54". The Commission and Oswego will mutually agree in a separate document to be executed prior to the closing of the WIFIA Loan on the value of the contribution.

D. "Average Contract Customer Rate Per 1,000 Gallons" means Total Contract Customer Revenue divided by Total Contract Customer Use.

E. "Bond Ordinances" means all of the Commission's ordinances and resolutions under which the Commission has or will authorize the issuance of, or issue, Bonds.

F. "Bonds" means Revenue Bonds and Other Bonds.

G. "Capital Cost Recovery Charge" means the amount necessary, pursuant to Section 0.02 of the Water Commission Act of 1985 (as added by Public Act 093-0226) and Commission Resolution No. R-79-04, entitled "A Resolution Expressing the Policy of the DuPage Water Commission Regarding the New Subsequent Customer Pricing Methodology," to recover Oswego's proportionate share of Original Capital Costs less Rebates, where Oswego's proportionate share of Original Capital Costs less Rebates is that proportion of Original Capital Costs less Rebates which Oswego's Full Water Requirements for 2022 and 2023 as reported by Oswego to the IEPA bears to the sum of the Full Water Requirements or Minimum Take or Pay Requirements (as defined in the Contract Customer Contract), as applicable, of all of the Commission's Contract Customers for such two years which the parties agree shall be \$11,047,790.00 based on the method of calculating such amount illustrated in Exhibit E attached to this Contract.

H. "Charter Customer Facilities" means all of the feeder mains, metering stations, and

pressure adjusting stations constructed as of May 1, 1992, solely for the purpose of initially connecting the Charter Customers to the Waterworks System.

I. Intentionally Omitted.

J. “Charter Customers” means the units of local government (not including the Commission) that are parties to the Charter Customer Contract, excluding, however, any such unit of local government whose rights and obligations under such Contract have been terminated, including without limitation the Village of Oswego.

K. “Commission” means the DuPage Water Commission, DuPage, Cook, and Will Counties, State of Illinois.

L. “Commission Connection Facilities” means the portions of the Waterworks System constructed by the Commission to initially connect the WaterLink Communities including the Oswego Unit System to the existing Waterworks System, which facilities are depicted in the preliminary plans attached as Exhibit B-2 to this Contract, as such facilities may be relocated, replaced, extended, or improved and may be used in the service of other customers from time to time. The Commission Connection Facilities include, among other items, metering station(s), including pipelines and equipment appurtenant thereto, and SCADA System facilities attributable to the Oswego Unit System, including equipment appurtenant thereto.

M. “Connection Facilities” means the Oswego Unit System Connection Facilities and the Commission Connection Facilities.

N. “Connection Facilities Cost” means the full actual cost incurred by the Commission in connection with (i) the design, bidding, contracting, managing, and

actual construction, installation, removal, relocation, replacement, extension, or improvement of the Connection Facilities, including without limitation equipment required for the operation of the Connection Facilities and all administrative, financing, supervisory, inspection, engineering, surveying, and legal fees, costs, and expenses associated therewith; (ii) the acquisition and divestment of lands, easements, and rights of way over lands and waters necessary for the construction, installation, removal, relocation, replacement, extension, or improvement of the Connection Facilities, and all administrative, title, surveying, and legal fees, costs, and expenses associated therewith; and (iii) the review and processing of plans and agreements for the construction, installation, removal, relocation, replacement, extension, or improvement of the Connection Facilities and in connection with the negotiation, preparation, consideration, and review of this Contract, including without limitation all legal, engineering, consulting, and administrative fees, costs, and expenses associated therewith; except as any of the above are included in Operation and Maintenance Costs.

O. "Contract" means this Water Purchase and Sale Contract.

P. "Contract Customer Contract" means the Water Purchase and Sale Contract between the Commission and the Contract Customers dated as of January 18, 2024.

Q. "Contract Customers" collectively means the Contract Customers, Oswego, and any other entity with whom the Commission has entered into, or may in the future enter into, a contract or agreement for the sale by the Commission of Lake Water to that entity, except only contracts and agreements providing for the delivery of Lake Water

during times of emergency only.

R. "Days" means calendar days.

S. "Determination Date" means the last day of December immediately preceding the Interest Period for which the Earned Interest Rate pursuant to this Contract is being calculated, but the effective date of any change in the Earned Interest Rate shall, for purposes hereof, be the first day of May following such Determination Date.

T. "Earned Interest Rate" means, with respect to each Interest Period under this Contract, the highest monthly average yield to maturity interest rate earned by the Commission (total funds) as reported monthly on the Commission's Schedule of Investments for the immediate preceding fiscal year (May 1 – April 30) as determined by the Commission, which determination shall be conclusive and binding upon Oswego absent manifest error, but the effective date of any change in the Earned Interest Rate shall, for purposes hereof, be the first day of May following such Determination Date.

U. "Fiscal Year" means the fiscal year of the Commission.

V. "Fixed Costs" means an amount sufficient at all times to pay the principal of and the premium, if any, and interest on any Revenue Bonds, to provide reserves required therefor, to provide an adequate depreciation fund for the Waterworks System, to comply with the covenants of all Revenue Bond Ordinances, and to pay reasonable capital costs necessary to carry out the corporate purposes and powers of the Commission; except as any of the above are included in Operation and Maintenance Costs.

W. “Full Water Requirements” means, (i) as it applies to calculating Oswego’s Capital Cost Recovery Charge, the amount of water necessary to meet the potable water requirements of all then current customers served by the Oswego Unit System at the time Oswego’s Capital Cost Recovery Charge is being calculated, (ii) as it applies to the Oswego Unit System for all other purposes of this Contract, the amount of water necessary from time to time to meet the potable water requirements of all then current customers served by the Oswego Unit System, and (iii) as it applies to other Contract Customers of the Commission, such Contract Customers’ full water requirements as defined in their respective contracts with the Commission.

X. “Interest Period” means (i) initially, the period commencing on the first date on which Oswego first becomes obligated to make payments under Subsection 7.D of this Contract and ending on the next succeeding first day of May and (ii) thereafter, each period commencing on the last day of the next preceding Interest Period and ending on the next succeeding first day of May; provided, however, that any Interest Period that otherwise extends beyond May 1, 2058, shall end on February 24, 2064.

Y. “Lake Water” means potable, filtered water drawn from Lake Michigan.

Z. “Operation and Maintenance Costs” means amounts payable by the Commission under the Water Supply Contract, except Underconsumption Costs, and all expenses incurred in the administration, operation, and maintenance of the Waterworks System and the accumulation of reserves related to payment of said costs. Operation and Maintenance Costs in any month shall be at least equal to the amount required to be deposited by the Commission in that month into the operation and maintenance funds

or accounts created under all Revenue Bond Ordinances.

AA. "Original Capital Costs" means all costs paid by the Commission for property owned by the Commission, as of April 30, 2024, without reduction for depreciation, including actual costs of construction, engineering, and capitalized interest on assets in service and under construction but excluding the cost of constructing the Charter Customer Facilities and financing costs other than interest capitalized in accordance with Generally Accepted Accounting Principles.

BB. "Original Revenue Bonds" means the Series 1987 Revenue Bonds, originally issued in the amount of \$200,000,000 pursuant to Ordinance No. 0-1-87 adopted January 15, 1987, and the Series 1993 Water Refunding Revenue Bonds, originally issued in the amount of \$182,755,000 pursuant to Ordinance No. 0-8-93 adopted April 8, 1993, and any other Revenue Bonds that may in the future be issued to refund or refinance all or any portion of the indebtedness represented by said Series 1987, 1993, 2003, and 2013 Revenue Bonds. As of the date of this Contract, all of the Original Revenue Bonds are fully paid and retired.

CC. "Oswego" means the Village of Oswego, located in Kendall and Will Counties, State of Illinois.

DD. "Oswego's Base Rate" means a water rate stated as dollars or cents per 1,000 gallons that is calculated by (i) the sum of all Operation and Maintenance Cost payments, all Fixed Costs payments, all Connection Facilities Cost payments, and all Capital Cost Recovery Charge payments under the Contract Customer Contract estimated to be made by Oswego pursuant to this Contract in the Fiscal Year for which Oswego's Base Rate pursuant to this Contract is being calculated and (ii) dividing the

resulting amount by the total amount of Lake Water, stated in 1,000 gallon units, estimated to be delivered to Oswego in said Fiscal Year.

EE. "Oswego Unit System" means the waterworks system described in Exhibit A attached to this Contract as well as any extensions or improvements of that system acquired by Oswego and used for the purpose of providing and transmitting water to its customers.

FF. "Oswego Unit System Connection Facilities" means those portions of the Oswego Unit System, lying downstream from the Point of Delivery, to be constructed pursuant to this Contract by Oswego at its expense to initially connect the Oswego Unit System to the Waterworks System, which facilities are depicted in the preliminary plans attached as Exhibit B-1 to this Contract, as such facilities may be relocated, replaced, extended, or improved from time to time. The Oswego Unit System Connection Facilities include, among other items, the pressure adjusting station(s) described in Subsection 4.A of this Contract and pipeline and equipment appurtenant thereto.

GG. "Other Bond Ordinances" means all of the Commission's ordinances and resolutions under which the Commission has or may authorize the issuance of, or issue, Other Bonds.

HH. "Other Bonds" means all of the Commission's debt obligations that are not Revenue Bonds, whether in the form of bonds, notes, or other evidence of indebtedness, in whatever original principal amount, together with any such additional non-revenue obligations authorized by statute to be issued by the Commission from time to time and refunding obligations issued to refund other such obligations.

II. "Point(s) of Delivery" means the point(s) at which the Lake Water delivered to Oswego pursuant to this Contract leaves the Commission's Waterworks System and enters the Oswego Unit System. A Point of Delivery shall be a point in the water main connecting the Commission's metering station(s) to Oswego's pressure adjusting station(s) located downstream from the inside face of the outside wall or foundation of the Commission's metering station(s) a distance of 10 feet or where such water main enters the outside face of the outside wall or foundation of Oswego's pressure adjusting station(s), whichever is closer to the Commission's metering station(s).

JJ. "Prime Rate" means the base corporate rate of interest then most recently announced by the largest commercial bank, measured in terms of total assets, located and doing banking business in the State of Illinois, which rate may or may not be said bank's lowest rate of interest charged by said bank for extensions of credit to debtors. The effective date of any change in the Prime Rate shall, for purposes hereof, be the effective date stated in the public announcement of said bank.

KK. "Rebates" means rebates formally declared as such by Commission Resolution as of the month prior to the month in which Oswego first becomes obligated to make payments under Subsection 7.D of this Contract. As of the date of this Contract, the Commission has formally declared \$106,326,287.00 in Rebates pursuant to Resolution Nos. R-19-94, R-21-95, R-15-96, R-24-97, R-18-98 and R-28-07.

LL. "Revenue Bond Ordinances" means all of the Commission's resolutions under which the Commission has or will authorize the issuance of, or issue, Revenue Bonds.

MM. "Revenue Bonds" means all of the Commission's debt obligations, including the Original Revenue Bonds, that are payable from the revenues of the Waterworks

System, whether in the form of bonds, notes, or other evidence of indebtedness, in whatever original principal amount, together with any such additional revenue obligations authorized by statute to be issued by the Commission from time to time and refunding revenue obligations issued to refund other such obligations.

NN. "SCADA System" means the Supervisory Control and Data Acquisition System of the Commission that provides an integrated control, communication, and security system for the Waterworks System, including data processing, management, transfer, and exchange; central operation; system control and monitoring; and operator-machine interfacing.

OO. "Trustee" means a trustee provided in a Bond Ordinance.

PP. "Underconsumer" means, for any given year, a Contract Customer of the Commission that takes less Lake Water in such year than such Contract Customer's Water Allocation times 365 times the Underconsumption Ratio for such year.

QQ. "Underconsumption" means the amount by which the amount of Lake Water actually taken by a Contract Customer of the Commission is less than the Underconsumption Ratio times such Contract Customer's Water Allocation times 365.

RR. "Underconsumption Costs" means any amount that the Commission is obligated to pay under the Water Supply Contract solely by reason of failure to accept delivery of the minimum quantity of Lake Water that the Commission is obligated to purchase under the Water Supply Contract.

SS. "Underconsumption Ratio" means, for any given year, (i) the minimum amount of Lake Water required to be taken by the Commission under the Water Supply

Contract divided by (ii) the sum of the Water Allocations of all Contract Customers of the Commission times 365.

TT. “Water Allocation” means, as it applies to other Contract Customers of the Commission, such Contract Customers’ water allocation as defined in their respective contracts with the Commission, and, as it applies to Oswego, the sum of Oswego’s allocations and allowable excesses from time to time of Lake Water for the Oswego Unit System pursuant to the Level of Lake Michigan Act, as amended from time to time (See State of Illinois Department of Transportation, Division of Water Resources Decision on 1989 Allocation Review, Order No. LMO 89-2 and subsequent orders of the State of Illinois Department of Transportation, Division of Water Resources, or the successor to its responsibilities, the State of Illinois Department of Natural Resources, Office of Water Resources); and such other amounts of Lake Water as Oswego may lawfully take for the Oswego Unit System. At any time when the Full Water Requirements of the Oswego Unit System shall exceed the Water Allocation for the Oswego Unit System, then “Water Allocation” shall mean the Full Water Requirements of the Oswego Unit System for all purposes of this Contract.

UU. “Water Supply Contract” means the water supply contract, dated March 19, 1984, between the Commission and the City of Chicago, Illinois, as amended, supplemented, or extended from time to time, or any alternative water supply agreement, and most recently in 2024 and extends until 2041.

VV. “Waterworks System” means all the Commission’s facilities, including land; easements; rights-of-way over lands and waters; pumping facilities, storage facilities,

metering stations, and other facilities; mains; and pipelines acquired and used for the purposes of providing and transmitting Lake Water from the Lake Michigan water supply system to the Commission's customers. The Oswego Unit System Connection Facilities are not part of the Waterworks System.

SECTION 3. WATER SUPPLY.

A. Agreement to Sell and Purchase. Subject to the provisions of this Contract, the Commission shall sell to Oswego and Oswego shall purchase from the Commission an amount of Lake Water necessary from time to time to serve the Oswego Unit System's Full Water Requirements. The Commission's obligation to Oswego to deliver Lake Water hereunder shall be limited, however, to a maximum annual amount equal to Oswego's then current Water Allocation times 365 and to a maximum rate of Lake Water to the Oswego Unit System in any one hour equal to 1.7 times Oswego's then current Water Allocation divided by 24.

B. Beginning of Obligations to Deliver and Receive Lake Water. Unless this Contract is sooner terminated by the Commission pursuant to Subsection 20.B of this Contract, the Commission shall be obligated to deliver Lake Water to the Oswego Unit System and Oswego shall be obligated to receive at the Oswego Unit System Lake Water delivered by the Commission immediately after completion of construction of the Connection Facilities and the water storage capacity required pursuant to Subsection 4.B of this Contract; provided, however, that Oswego shall have the right to receive Lake Water pursuant to this Contract prior to the completion of construction of the required storage capacity if such storage capacity has been substantially completed to the point where it is capable of serving its intended function or would be

capable of serving its intended function except for the fact that painting or other finishing and restoration work are not complete.

C. Limits on Supply. The Commission shall use its best efforts to furnish Lake Water to Oswego as hereinabove provided, but Oswego acknowledges and agrees that the Commission's obligation hereunder is limited by:

- (i) The amount of Lake Water from time to time available to the Commission; and
- (ii) Provisions in contracts between the Commission and its Contract Customers and other customers related to curtailment and other limits on the supply of Lake Water; and
- (iii) The capacity of the Waterworks System; and
- (iv) Ordinary transmission loss, including standard metering error, between the Commission's source of supply and the Point of Delivery to the Oswego Unit System; and
- (v) The other provisions of this Contract, including but not limited to Section 20.

D. Emergency or Maintenance Turn-Off. The Commission undertakes to use reasonable care and diligence to provide a constant supply of Lake Water as herein provided for but reserves the right at any time to turn off the flow of Lake Water in its mains for emergency and maintenance purposes. The Commission shall give notice not less than 48 hours in advance of any turn-off for maintenance purposes and it shall give such notice as is reasonable under the particular circumstances of any turn-off for emergency purposes.

E. Curtailment; Emergency Use of Other Sources. If it becomes necessary for the Commission to limit its delivery of Lake Water to its customers for any reason, Oswego shall be entitled, to the extent possible, to receive during such period of

curtailment a pro rata share of available Lake Water as determined by the ratio of (i) the Oswego Unit System's total Lake Water use during the prior Fiscal Year for other than start-up purposes pursuant to Subsection 10.I of this Contract to (ii) the sum of Lake Water use during the prior Fiscal Year of all of the Commission's customers entitled to Lake Water during such period of curtailment. Prior to the Commission's delivery of Lake Water to the Oswego Unit System for a full Fiscal Year for other than start-up purposes pursuant to Subsection 10.I of this Contract, Oswego shall be entitled, to the extent possible, to receive during such period of curtailment a pro rata share of available Lake Water as determined by the ratio of the Oswego Unit System's Full Water Requirements during the prior Fiscal Year to the sum of (i) Lake Water use during the prior Fiscal Year of all of the Commission's other customers entitled to Lake Water during such period of curtailment and (ii) the Oswego Unit System's Full Water Requirements during the prior Fiscal Year. Oswego, in cases of emergency or when the Commission for whatever reason is unable to meet the Oswego Unit System's Full Water Requirements, may, subject to the terms, conditions, and limitations set forth in Subsection 9.N of this Contract, serve its customers from any source; provided, however, that Oswego shall continue to pay all amounts due to the Commission hereunder during such period as if the Oswego Unit System were receiving its Full Water Requirements from the Commission.

F. Water Quality. The Commission shall supply Oswego with Lake Water of a quality commensurate to that furnished to the Commission's other Contract Customers, and meeting the requirements of any federal, State of Illinois, or local

agency as shall have jurisdiction from time to time for the operation of public water supplies such as the Waterworks System. The Commission bears no responsibility for the contamination of Lake Water or deterioration of water quality occurring beyond the Points of Delivery to the Oswego Unit System.

SECTION 4. DELIVERY; STORAGE.

A. Oswego Unit System Connection Facilities. Oswego shall receive its supply of Lake Water at the Oswego Unit System Points of Delivery at pressures that will vary from time to time. Oswego, at its own expense and pursuant to the schedule established in Section 10 of this Contract, shall site, design, construct, operate, maintain, and when necessary, replace the Oswego Unit System Connection Facilities, including a pressure adjusting station immediately downstream from the Points of Delivery. Initial design and construction plans and specifications for the Oswego Unit System Connection Facilities, and any future modifications thereof, shall be submitted in advance of construction or modification to the Commission for review and approval, which approval shall not be unreasonably withheld. In the event the Oswego Unit System or the Oswego Unit System Connection Facilities are to be relocated, replaced, extended, or improved at the request of the Commission, its successor, other than those circumstances where the Commission is compelled to relocate the Oswego Unit System or the Oswego Unit System Connection Facilities for a non-Commission conflicting public infrastructure project or by State or Federal mandate, Oswego will be entitled to reasonable and fair market value recovery for all costs without reduction for depreciation including actual costs of construction, engineering, and capitalized

interest on assets in service and under construction and financing costs other than interest capitalized in accordance with Generally Accepted Accounting Principles.

B. Storage. Oswego shall provide sufficient storage capacity within the Oswego Unit System to store not less than two times the annual average daily water demand of the Oswego Unit System; provided, however, that said requirement shall be reduced by (i) the amount of operable shallow well capacity (stated in gallons per hour) maintained by Oswego in the Oswego Unit System up to a maximum of 10 percent (10%) of said requirement plus (ii) an amount equal to the storage capacity maintained by the Commission in its Waterworks System multiplied by a fraction, the numerator of which is the annual average daily water demand of the Oswego Unit System and the denominator of which is the total annual average daily water demands of all Contract Customers. The calculation of said water storage capacity requirement for the Oswego Unit System is provided in Exhibit C attached to this Contract. In accordance with said requirement, Oswego, at its own expense and pursuant to the schedule established in Section 10 of this Contract, shall construct for the Oswego Unit System at least the amount of water storage capacity shown on Exhibit C to this Contract as the "Minimum Additional Required Storage." Such water storage capacity shall be in addition to the amount of water storage capacity shown on Exhibit C to this Contract as the "Existing Storage" in the Oswego Unit System. Oswego shall properly maintain all such water storage capacity, including operable shallow well capacity, in good and serviceable condition. If at any time Oswego's water storage capacity in the Oswego Unit System, including its allowances for operable shallow well capacity and Commission storage capacity as provided above, falls below 1.9 times the annual

average daily water demand of the Oswego Unit System, then Oswego, within 24 months after such level of deficiency is reached, shall construct additional water storage capacity within the Oswego Unit System of sufficient quantity to increase the total storage capacity of the Oswego Unit System, including its allowances for operable shallow well capacity and Commission storage capacity as provided above, to not less than two times the annual average daily water demand of the Oswego Unit System.

C. Metering of Shallow Wells. Oswego shall furnish, install, and maintain a meter on each of its operable shallow wells. All such meters shall be of standard make and shall be subject to inspection and examination by any employee or agent of the Commission at all reasonable times. Oswego shall calibrate all such meters at least once in each Fiscal Year. Oswego shall notify the Commission of the time, date, and place of each calibration at least five days in advance thereof, and a representative of the Commission shall have the right to observe any adjustments made to such meters in case any adjustments shall be necessary. The Commission shall have the right to place any or all of such meters under seal at any time.

D. Surges and Back-Flows. Oswego's operation of its pressure adjusting station shall not cause surges or back-flows into the Waterworks System, nor shall the operation of the Oswego's pressure adjusting station cause the Waterworks System pressure to drop below 20 pounds per square inch. The Commission shall not be responsible for any damage to the Oswego Unit System or the Oswego Unit System Connection Facilities caused by the design, operation, or maintenance of the Connection Facilities.

E. Maintenance of System; Water Quality; Prevention of Waste. Oswego

shall operate the Oswego Unit System and the Oswego Unit System Connection Facilities in such a manner as at no time to place the Commission and the Waterworks System in jeopardy of failing to meet the regulations of any agency or governmental authority having jurisdiction over the Commission's operation of its Waterworks System. The Commission and Oswego shall notify each other immediately of all emergency and other conditions which may directly or indirectly affect the Waterworks System, the Oswego Unit System, the Connection Facilities, or the quantity or quality of the Lake Water received pursuant to this Contract.

SECTION 5. MEASURING EQUIPMENT.

A. Metering Station and Instrumentation. The Commission shall, pursuant to the timetable established in Section 10 of this Contract, furnish, and install at the Points of Delivery a metering station containing the necessary equipment and devices of a type meeting the standards of the American Water Works Association for measuring properly the quantity of Lake Water delivered under this Contract, including all structures as the Commission shall deem necessary to house such equipment and devices. Such furnishing and installing of a metering station shall be done in substantial conformance with the preliminary plans therefor attached as Exhibit B-2 to this Contract, as such preliminary plans may be revised by mutual agreement of the Commission and Oswego. The Commission shall own, operate, maintain, and replace such metering station and all equipment and structures related thereto.

The metering station shall be located at a site or sites selected and acquired by Oswego, and title transferred to the Commission, free and clear of all liens, claims,

encumbrances, and restrictions unless otherwise approved by the Commission in writing. Oswego shall be responsible for maintaining the grounds and landscaping, including but not limited to shrubbery and other plantings, located on each site provided. Such sites shall be subject to reasonable review and approval of the Commission, without charge to the Commission and pursuant to the timetable established in Section 10 of this Contract, shall grant to the Commission all necessary and insured easements for such site(s) and access thereto to the reasonable satisfaction of the Commission in a form similar to that attached as Exhibit D to this Contract and satisfactory to the Commission's attorneys. Oswego also shall grant to the Commission all necessary and insured easements for the appropriate location and installation of antennas and appurtenant facilities for the Commission's SCADA System attributable to the Oswego Unit System on property owned by Oswego or on property lying within the corporate limits of Oswego, free and clear of all liens, claims, encumbrances, and restrictions unless otherwise approved by the Commission in writing. Such SCADA System antennas or facilities shall be installed on such easements in a manner that will reduce so far as reasonably possible any interference with the telemetry of the Oswego Unit System.

Oswego shall have access to the metering station for examination and inspection at reasonable times, but the reading for billing purposes, calibration, and adjustment of the equipment therein shall be done only by the employees or agents of the Commission.

B. Records. For the purpose of this Contract, the official record of readings

of each meter at the metering station shall be the journal or other record book of the Commission in its office in which the records of the employees or agents of the Commission who take the readings are or may be transcribed. Upon written request of Oswego, the Commission will give Oswego a copy of such journal or record book, or permit Oswego to have access thereto in the office of the Commission during regular business hours.

C. Calibration. At least once in each Fiscal Year, the Commission shall calibrate its meters dedicated to measuring the Lake Water delivered to the Oswego Unit System, in the presence of a representative of Oswego, and the Commission and Oswego shall jointly observe any adjustments that are made to the meters in case any adjustments shall be necessary. If any check meters have been installed, then such check meters shall be calibrated at least once in each Fiscal Year by Oswego in the presence of a representative of the Commission, and the Commission and Oswego shall jointly observe any adjustments that are made to the meters in case any adjustments shall be necessary.

D. Check Meters. Oswego, at its option and its own expense, may install and operate a check meter to check each meter installed by the Commission, but the measurement of Lake Water for purposes of this Contract shall be solely by the Commission's meters, except in the cases hereinafter specifically provided to the contrary. All check meters shall be of standard make and shall be subject to inspection and examination by any employee or agent of the Commission at all reasonable times. The calibration and adjustment of check meters shall be made only by Oswego, except

during any period when a check meter may be used under the provisions hereunder for measuring the amount of Lake Water delivered to Oswego, in which case the calibration and adjustment of such check meter shall be made by the Commission with like effects as if such check meter had been furnished and installed by the Commission.

E. Meter Malfunctions. If the Commission or Oswego at any time observes a variation between a meter and a check meter or any evidence of meter malfunction, such party shall promptly notify the other party, and the Commission and Oswego shall then cooperate to procure an immediate calibration test and such adjustment, replacement, or other work necessary to return such meter to accuracy. The party who discovers such variation or malfunction shall give the other party written notice not less than 48 hours prior to the time of any test of any meter (which tests shall be conducted during normal working hours) so that the other party may conveniently have a representative present. If such representative is not present after the required notification at the time set in such notice, calibration and adjustment may proceed in the absence of said representative notwithstanding any other provision of this Subsection 5.E. If the percentage of inaccuracy of any meter is found to be in excess of two percent, registration thereof shall be corrected by agreement of the Commission and Oswego based upon the best data available, for a period extending back to the time when such inaccuracy began if such time is ascertainable, or for a period extending back one-half of the time elapsed since the last date of calibration (but in no event further back than a period of six months) if such time is not ascertainable.

If for any reason any meter is out of service or out of repair so that the amount of Lake Water delivered cannot be ascertained or computed from the reading thereof, then the

Lake Water delivered during the period such meter is out of service or out of repair shall be deemed to be the registration of the check meter if one has been installed and is registering accurately, or, in the event that no check meter has been installed or the check meter is registering inaccurately, shall be estimated:

- (i) By correcting the error if the percentage of the error is ascertainable by calibration tests or mathematical calculations; or
- (ii) If the error is not ascertainable by calibration tests or mathematical calculation, by estimating the quantity of delivery by considering deliveries during preceding periods under similar conditions when the meter or meters were registering accurately, adjusted for the addition of new customers to the Oswego Unit System.

F. Removal of Metering Station and SCADA System Facilities. Within ninety (90) days after the termination of this Contract (absent a failure to renew), the Commission, at its own expense and in its discretion, may remove the metering station, including equipment, and the SCADA System antennas and appurtenant facilities from the property of Oswego and release the perpetual easement therein. If the Commission fails to remove such station, equipment, and facilities, as aforesaid, Oswego may take title to such station, equipment, and facilities.

SECTION 6. UNIT OF MEASUREMENT.

The unit of measurement for Lake Water delivered hereunder shall be gallons of water, U.S. Standard Liquid Measure, and all measuring devices shall be so calibrated unless the Commission and Oswego otherwise agree. Should it become necessary or desirable to use other units of measurement, the basis of conversion shall be that 7.48 gallons is equivalent to one cubic foot.

SECTION 7. PRICES AND TERMS OF PAYMENT.

A. Operation and Maintenance Costs Payment. Oswego shall pay monthly to the Commission, at the time specified in Subsections 7.G and 7.M below, a share of the Commission's Operation and Maintenance Costs for each month, which shall be an amount equal to the then current price per 1,000 gallons for Operation and Maintenance Costs times the quantity of Lake Water divided by 1,000 delivered by the Waterworks System to the Oswego Unit System for such month. At any time after the commencement of Lake Water delivery, no Lake Water is being supplied through the Waterworks System to any Contract Customer, Oswego's share of monthly Operation and Maintenance Costs for the Oswego Unit System shall be that proportion of those costs which the Oswego Unit System's Water Allocation bears to the total Water Allocations of all of the Commission's customers required to make Operation and Maintenance Costs payments during the same period.

B. Fixed Costs Payment. Subject to the single limitation on its obligation to pay Fixed Costs set forth in this Subsection 7.B, Oswego shall pay monthly to the Commission, at the time specified in Subsections 7.G and 7.M below, one-twelfth of the Oswego Unit System's share of Fixed Costs for each Fiscal Year. However, as of the date of this Contract, the Fixed Costs are \$0 per month. For the purposes of this Contract, the Oswego Unit System's share of Fixed Costs for each Fiscal Year shall be that proportion of Fixed Costs which the Oswego Unit System's Full Water Requirements for the two preceding calendar years prior to such Fiscal Year bears to the sum of the Full Water Requirements or Minimum Take or Pay Requirements, as

applicable, of all of the Commission's Contract Customers for such two preceding calendar years who are not relieved from Fixed Costs payments pursuant to the terms of their contracts. Prior to the Commission's delivery of Lake Water to the Oswego Unit System for two calendar years for other than start-up purposes pursuant to Subsection 10.I of this Contract, the Oswego Unit System's share of Fixed Costs shall be that portion of Fixed Costs which the Oswego Unit System's Water Allocation bears to the total Water Allocations or the Full Water Requirements or Minimum Take or Pay Requirements, whichever is then applicable, of all of the Commission's Contract Customers who are not relieved from Fixed Costs payments pursuant to the terms of their contracts. Subject to the following single limitation, Oswego's obligation to make all payments of Fixed Costs as required hereunder is unconditional and irrevocable, payable without setoff or counterclaim, and irrespective of whether Lake Water is ever furnished, made available, or delivered to the Oswego Unit System, or whether the Waterworks System is completed, operable, or operating, and notwithstanding suspension, interruption, interference, reduction, or curtailment of the supply of Lake Water. Oswego's obligation to pay Fixed Costs hereunder is subject to the single limitation that, if for any period of time, and only during such period of time, the Commission is in fact supplying the Full Water Requirements or Minimum Take or Pay Requirements, as applicable, to Contract Customers of the Commission, other than Oswego, whose Full Water Requirements and Minimum Take or Pay Requirements are more than 85 percent of the sum of the Full Water Requirements or Minimum Take or Pay Requirements, as applicable, of all Contract Customers of the Commission, and during such time the Commission is unable to supply any Lake Water to the Oswego

Unit System, then Oswego shall have no obligation to pay Fixed Costs for the Oswego Unit System. However, as of the date of this Contract, the Capital Recovery Cost Credit is \$0 because Fixed Costs are currently \$0.

C. Connection Facilities Cost Payment. Oswego shall pay to the Commission its share of the Connection Facilities Cost in accordance with the Waterlink Communities Intergovernmental Cost Share Agreement, wherein Oswego commits and agrees to pay 35.36% of the total Connection Facilities Cost. The Commission is not a party to the WaterLink Communities' Intergovernmental Cost-Share Agreement and has no responsibility or liability as to any true-up or adjusted accounting between the WaterLink Communities. Contemporaneously and pursuant to this Contract, Oswego and the Commission shall enter into an WaterLink Project Escrow Intergovernmental Agreement with the Village of Oswego (the "Escrow IGA") substantially in the form attached hereto as Exhibit G. In the event a line of credit issued by the Commission to Oswego and any of the WaterLink Communities for Connection Facilities Costs the total line of credit amount provided to the WaterLink Communities shall not exceed Twenty-one Million Dollars (\$21,000,000) (the "Commitment Amount"). Oswego's obligation to make its share of the payment for the Connection Facilities Cost as required in and under the Escrow IGA is unconditional and irrevocable, and may be payable without setoff or counterclaim, and irrespective of whether Lake Water is ever furnished, made available, or delivered to Oswego, or whether the Waterworks System is completed, operable, or operating, and notwithstanding suspension, interruption, interference, reduction, or curtailment of the supply of Lake Water.

D. Capital Cost Recovery Charge Payment. Oswego shall pay monthly to the Commission, at the time specified in Subsections 7.G and 7.M below, an amount calculated by amortizing the Capital Cost Recovery Charge (less any Asset-in-Kind Amount), in equal monthly installments of principal and interest, at a rate per annum equal to the Earned Interest Rate determined for each Interest Period plus one percent, over the life of the Contract Customer Contract remaining as of the month in which Oswego first becomes obligated to make such payment; provided, however, that such monthly installment may be adjusted by the Commission, on May 1 of each year thereafter, to ensure amortization of the then-current amount of the Capital Cost Recovery Charge (less any Asset-in-Kind Amount) remaining unpaid, as of such May 1, over the life of the Contract Customer Contract then remaining, and to reflect any change in the Earned Interest Rate, as of such May 1. The method of calculating the Capital Cost Recovery Charge is illustrated in Exhibit E attached to this Contract. Oswego's obligation to make all Capital Cost Recovery Charge payments as required hereunder is unconditional and irrevocable, payable without setoff or counterclaim, and irrespective of whether Lake Water is ever furnished, made available, or delivered to Oswego, or whether the Waterworks System is completed, operable, or operating, and notwithstanding suspension, interruption, interference, reduction, or curtailment of the supply of Lake Water.

E. Underconsumption Costs Payment. If Oswego is an Underconsumer at the Oswego Unit System, then Oswego shall pay, at the time specified in Subsections 7.G and 7.M below, its share of Underconsumption Costs as determined and assessed by

the Commission after notification of such costs under the Water Supply Contract. In such event, Oswego's share of Underconsumption Costs for the Oswego Unit System for a year shall be equal to the ratio of its Underconsumption to the aggregate Underconsumption of all Underconsumers for such year.

F. Default Shares. If any of the Commission's Contract Customers shall default in any payment to the Commission, or any part of any payment, including default shares, Oswego agrees to pay to the Commission a share of the amount so in default, which share shall be in the same proportion as the Oswego Unit System's share of Aggregate Costs for the month prior to the month of the default bears to the sum of the shares of Aggregate Costs in that month of all of the Commission's Contract Customers not in default and obligated to make payments with respect to the amount so in default.

Subject to Subsection 7.M below, Oswego's share of the amount so in default shall be due and payable 21 days after the Commission's written demand therefor. The demand shall include the Commission's calculations of the amount due by Oswego hereunder. If and when the defaulting customer makes a payment to the Commission of a defaulted amount or interest thereon for which Oswego made a payment to the Commission under this Subsection 7.F, then the Commission will pay to Oswego its proportionate share of such amount, including such interest.

G. Bills and Due Date. Except with respect to the payment of the Possible Shortfall required pursuant to Subsection 7.C above and the payment of default shares pursuant to Subsection 7.F above, the Commission shall notify Oswego of the total

amount due under this Contract for each month on or before the 10th day of the following month. Oswego's costs for each month shall be due and payable and must be received at the offices of the Commission, on or before the 10th day of the month following the month of the Commission's notification or within 28 days after the date of notification, whichever is later.

H. Disputed Payments. If Oswego desires to dispute any payment, or part thereof, due or reasonably claimed by the Commission to be due under this Contract, Oswego shall nevertheless pay the full amount of any such payment when due and include with such payment written notification to the Commission that charges are disputed, the grounds for dispute, and the amount in dispute. No adjustment or relief on account of any disputed charges shall be made unless disputed charges are the subject of such notice within the time herein specified, or within a reasonable period from the time Oswego knew or should have known of the facts giving rise to the dispute.

Upon receipt of a notification of dispute, representatives of the Commission shall meet promptly with representatives of Oswego to resolve such dispute. No adjustment or relief on account of any disputed charges shall be made unless disputed charges are the subject of such notice within twenty-one (21) days of receipt by Oswego of the bill, or within a reasonable period from the time Oswego knew or should have known of the facts giving rise to the dispute.

If the Commission and Oswego determine that all or a portion of the disputed payment should be refunded to Oswego, then such sum shall be refunded with interest thereon

at the rate established in Subsection 7.I below from the date such disputed payment was made.

I. Interest on Overdue Payments. If Oswego shall fail to make any payment required under this Contract, the Escrow IGA, or the Capital Cost Recovery Charge IGA to the Village of Oswego on or before its due date, Oswego shall be in default, and interest on the amount of such payment shall accrue to the extent permitted by law, and be compounded on a monthly basis, during the period of non-payment at the higher of:

- (i) the weighted average effective interest rate on all series of Bonds of the Commission any of which are then outstanding plus two percent; or
- (ii) the Prime Rate plus five percent.

Such interest shall accrue from the date such payment becomes due until paid in full with interest as herein specified. If such payment is not made by Oswego within 30 days after the date such payment becomes due, then the Commission, at its option and in its discretion, may reduce or discontinue delivery of Lake Water to the Oswego Unit System until the amount due the Commission is paid in full with interest as herein specified. The Commission shall give notice to Oswego not less than 20 days prior to the event of its intention to reduce or discontinue delivery of Lake Water in accordance with this Subsection 7.I and shall provide Oswego an opportunity for a hearing before the Commission prior to any reduction or discontinuance. If the Commission reduces or discontinues the delivery of Lake Water under such circumstances, Oswego shall nevertheless continue to be liable to pay all charges provided for herein as if the

Oswego Unit System were receiving its Full Water Requirements from the Commission. The rights specified in this Subsection 7.I shall be in addition to all other rights and remedies available to the Commission under this Contract, at law, or in equity for breach of any of the provisions of this Contract.

J. Security Deposit. If Oswego is at any time in default on any payment due under this Contract, the Escrow IGA, or the Capital Cost Recovery Charge IGA, and the default is not cured within 30 days after the due date of the defaulted payment, then the Commission, at its option and in its discretion, may require Oswego, as a further obligation under this Contract, to deposit in a separate account in the Commission's name a sum of money as security for the payment of Oswego's obligations hereunder of a reasonable amount determined by the Commission. Oswego's compliance with the Commission's demand for such a security deposit shall be a condition precedent to the curing of such Oswego default and the restoration of the Lake Water service to the Oswego Unit System if such Lake Water service has been reduced or discontinued by reason of such default. The security deposit or any part thereof may be applied, at the Commission's option and in its discretion, to any subsequent default by Oswego in any payments due under this Contract, the Escrow IGA or the Capital Cost Recovery Charge IGA. If so applied, Oswego shall provide funds within 10 days to restore the security deposit to the amount required by the Commission. At the earliest of the end of the term of this Contract, or a term of two years after the curing of the most recent default by Oswego, or such earlier time that the Commission at its option and in its discretion may determine, any security deposit shall be returned to Oswego if Oswego

has performed all its obligations under this Contract, the Escrow IGA or the Capital Cost Recovery Charge IGA. Oswego shall not be entitled to receive any interest on any security deposit.

K. Prepayments. Subject to the limitations of this paragraph, Oswego may (i) at any time, and from time to time, before Oswego first becomes obligated to make payments of Operation and Maintenance Costs pursuant to Subsection 7.M below, and (ii) no more frequently than once in any given year thereafter, at any time during the month of December, prepay, in whole or in part, the Connection Facilities Cost, the Capital Cost Recovery Charge Amount due, or other amount previously agreed to, pursuant to this Contract, without premium or penalty, upon at least one business day's irrevocable notice to the Commission, specifying the date and amount of prepayment. If such notice is given, Oswego shall make such prepayment and the payment amount specified in such notice shall be due and payable on the date specified therein. The proceeds of any such prepayment shall be applied by the Commission first, to the payment of accrued and unpaid interest, if any, on the Connection Facilities Cost accruing after the date specified in Subsection 7.M below; second, to the payment of the unpaid principal balance of the Connection Facilities Cost; third, to the payment of accrued and unpaid interest, if any, on the Capital Cost Recovery Charge Amount accruing after the date specified in Subsection 7.M below; and fourth, to the payment of the unpaid principal balance of the Capital Cost Recovery Charge Amount; provided, however, that Oswego shall not be entitled to make any such prepayment pursuant to this paragraph if Oswego's Base Rate during the Fiscal Year next following

the date of such payment would be, as estimated by the Commission, less than the Average Contract Customer Rate Per 1,000 Gallons. For purposes of calculating Oswego's Base Rate, any such prepayment shall be deemed to have been paid effective as of the 30th day of April next following the date of such payment or the 30th day of April next following the month in which Oswego first becomes obligated to make such Connection Facilities Cost payments and Capital Cost Recovery Charge Amount payments, whichever is later. Oswego shall not be entitled to, nor receive any credit for, interest on any such prepayment.

Notwithstanding anything to the contrary contained herein, in the event the Oswego Unit System has not been constructed, installed, and completed, to a point where it is capable of serving its intended function at the time Oswego first becomes obligated to make payments of Operation and Maintenance Costs pursuant to Subsection 7.M below, then the Commission may, in its sole and absolute discretion, declare the principal amount of the Connection Facilities Cost remaining unpaid, in whole or in part, the principal amount of the Capital Cost Recovery Charge remaining unpaid, in whole or in part, or both of such remaining unpaid costs, in whole or in part, due and payable within 30 days following the date of such declaration, together with accrued and unpaid interest as herein specified on such declared due amounts to the date paid, unless the Commission shall have exercised its right to terminate this Contract pursuant to Subsection 20.C of this Contract. The rights specified in this paragraph shall be in addition to all other rights and remedies available to the Commission under this Contract, at law, or in equity for breach of any of the provisions of this Contract.

L. Enforcement of Provisions Hereof by Other Customers. Oswego acknowledges that its obligation to make payments pursuant to the terms of this Section 7 is of benefit to the Commission's Contract Customers, Bondholders, and any Trustee. Accordingly, Oswego agrees that, in addition to the Commission, Bondholders, a Trustee or other parties allowed by law are entitled to enforce the provisions of this Contract. Further, any three or more of the Commission's Contract Customers acting together may enforce the provisions of this Section 7, but only if the Commission has not acted to enforce such provisions within 90 days after any failure by Oswego to make a payment hereunder.

M. Beginning of Obligation to Pay. Notwithstanding any other provision of this Contract, the obligation to make any and all payments under this Contract, except only payments of Operation and Maintenance Costs pursuant to Subsection 7.A above and payment of any Possible Shortfall required pursuant to Subsection 7.C above, shall begin on the Commission's first regular billing cycle after the earlier to occur of (i) the first delivery of Lake Water to the Oswego Unit System or any portion thereof or (ii) 12 months following completion of construction of the Commission Connection Facilities, other than the SCADA System facilities, to the point where they are capable of serving their intended function or would be capable of serving their intended function except for the fact that the Oswego Unit System Connection Facilities are not complete. The obligation to make payments of Operation and Maintenance Costs pursuant to Subsection 7.A above shall begin on the Commission's first regular billing cycle after the earlier to occur of (i) the first delivery of Lake Water to the Oswego

Unit System or any portion thereof or (ii) completion of construction of the Commission Connection Facilities, other than the SCADA System Facilities, to the point where they are capable of serving their intended function or would be capable of serving their intended function except for the fact that the Oswego Unit System Connection Facilities are not complete. At any time prior to the first delivery of Lake Water to the Oswego Unit System when Oswego is obligated to make payments pursuant to this Subsection 7.M, such payments shall be based on the Full Water Requirements of the Oswego Unit System.

SECTION 8. SPECIAL CONDITIONS AND COVENANTS.

A. Construction of the Commission Connection Facilities; No Delay Damages; Supply of Lake Water. The Commission will make a diligent effort to have the Commission Connection Facilities completed to the Points of Delivery so as to furnish Lake Water to the Oswego Unit System by the date specified in Subsection 10.H of this Contract, but the Commission does not in any way guaranty delivery by such date.

Oswego acknowledges and agrees that the Commission shall not be liable to Oswego for any damages occasioned by or in any way related to delay in the delivery of Lake Water to the Oswego Unit System, and all payments from Oswego provided for under this Contract shall remain due and payable in accordance with the terms of this Contract notwithstanding any such delay.

After Lake Water is first tendered for delivery to the Oswego Unit System at the Points of Delivery for other than start-up purposes pursuant to Subsection 10.I of this Contract, the Commission, subject to the other terms and conditions of this Contract,

shall use its best efforts to continually hold itself ready, willing, and able to supply Lake Water to the Oswego Unit System at such Points of Delivery. The Commission also shall use its best efforts, consistent with its prior obligations and legal obligations to its customers and consistent with the fair and equitable treatment of all of its Contract Customers, to supply the Oswego Unit System with such additional amounts of Lake Water as from time to time may be allocated to the Oswego Unit System over and above the Oswego Unit System's present Water Allocation; provided, however, that the Commission does not in any way guaranty a supply of such additional amounts.

B. Lake Water Only; Costs. Except with the prior approval of Oswego, the Commission shall not deliver any water to the Oswego Unit System other than Lake Water. Except for Lake Water supplied for start-up purposes pursuant to Subsection 10.I of this Contract, costs for Lake Water charged to Oswego by the Commission pursuant to this Contract shall include only the costs set forth in Section 7 of this Contract.

C. Title to Lake Water. Title to all Lake Water supplied hereunder shall remain in the Commission to the Points of Delivery and thereupon shall pass to Oswego.

D. Emergency Supply. Subject to the terms, conditions, and limitations set forth in Subsection 9.N of this Contract, Oswego may contract for a temporary supply of water in case of an emergency from any unit of local government or any other entity. Oswego shall notify the Commission and shall promptly provide the Commission with copies of all such contracts.

E. Covenants to Be Set Out in Bond Ordinance. Oswego acknowledges the existence, and its understanding of the provisions, of certain Bond Ordinances pursuant to which the Commission has previously issued its Bonds. Oswego further acknowledges and agrees that said Bond Ordinances grant to Bondholders certain rights to enforce certain duties of the Commission and its customers, including those with respect to the making of rates and charges and the collection of revenues, and that such Bondholder rights may be included in any subsequent Bond Ordinances.

F. Payments Hereunder are an Operational Expense of the Oswego Unit System. Oswego agrees that, to the fullest extent permitted by law or contract, all payments to be made by Oswego pursuant to this Contract shall constitute operating expenses of the Oswego Unit System as to any and all revenue bonds of Oswego which are supported in whole or in part by a pledge of the revenues of the Oswego Unit System, with the effect that Oswego's obligation to make payments from its water revenues under this Contract has priority over its obligation to make payments of the principal and of the premium, if any, and interest on any such bonds which are or will be supported in whole or in part by a pledge of any Oswego Unit System revenues. Oswego shall make all budgetary, emergency, and other provisions and appropriations necessary to provide for and authorize the prompt payment to the Commission of all rates and charges under this Contract. The obligations of Oswego under this Contract are further payable from all other accounts of the Oswego Unit System in which there are lawful available funds. In any revenue bond or indenture hereafter issued by Oswego, the priority of lien established pursuant to this Contract shall be expressly

provided and set forth in said bond ordinances or resolutions. Notwithstanding the foregoing, however, Oswego's obligations under the IEPA Loans referenced in Subsection 9.D to be secured in whole or in part by a pledge of Oswego Unit System revenues to the IEPA shall have priority of lien over Oswego's obligation to make payment from its water revenues under this Contract.

SECTION 9. ADDITIONAL OSWEGO COVENANTS.

A. Maintenance of Corporate Existence. Oswego agrees that during the term of this Contract it will maintain its municipal corporate existence, it will continue to be a municipal corporation in good standing in the State of Illinois, it will not dissolve or otherwise dispose of all or substantially all of the assets of the Oswego Unit System.

B. Maintenance and Operation of Oswego Unit System. Oswego shall own and maintain the Oswego Unit System and the Oswego Unit System Connection Facilities, and all improvements and extensions of the Oswego Unit System and the Oswego Unit System Connection Facilities, in good repair and working order, will operate the Oswego Unit System and the Oswego Unit System Connection Facilities efficiently, and will punctually perform all duties with respect to the Oswego Unit System and the Oswego Unit System Connection Facilities as may be required by this Contract, and by the Constitution and laws of the State of Illinois and all other applicable laws. In the event of any deterioration, injury, damage, or other loss to the Oswego Unit System or the Oswego Unit System Connection Facilities affecting Oswego's ability to deliver water to any of Oswego's customers, Oswego shall promptly restore the Oswego Unit System or the Oswego Unit System Connection

Facilities and their capacity to so deliver water.

C. Rate Covenant. Oswego shall take all necessary actions to establish, maintain, revise as necessary, and collect rates and charges for customers of the Oswego Unit System as shall be required from time to time to produce revenues at least sufficient:

(i) To pay all amounts due under this Contract, the Escrow IGA, the Capital Cost Recovery Charge IGA and the IEPA Loans referenced herein, and to pay all other costs of operation and maintenance of the Oswego Unit System and the Oswego Unit System Connection Facilities; and

(ii) To provide an adequate depreciation fund for the Oswego Unit System and the Oswego Unit System Connection Facilities; and

(iii) To make all deposits in all funds and accounts required by the terms of resolutions or ordinances authorizing any obligation of Oswego payable from the revenues of the Oswego Unit System; and

(iv) To pay the principal of and the premium, if any, and interest on all obligations of Oswego payable from the revenues of the Oswego Unit System including, but not limited to, its obligations under the Escrow IGA, the Capital Cost Recovery Charge IGA, and to repay the IEPA Loans referenced in Subsection 9.D.

D. Future Subordination of Obligations. Any ordinance, resolution, motion, or other action of Oswego which authorizes the issuance after the date of this Contract of any obligation of Oswego to be paid from the revenues of the Oswego Unit System will expressly provide that revenues of said System may be used to pay principal of, and the premium, if any, and the interest on such obligations only to the extent that those revenues exceed the amounts required to pay the operation and maintenance expenses of said System including, expressly, all amounts payable from time to time

under this Contract, except for any present or future ordinance, resolution, motion or other action of Oswego which authorizes, or has authorized, it to borrow funds from and enter a loan agreement with the Illinois Environmental Protection Agency (the “IEPA Loans”) which may provide for the collection, segregation, distribution and/or pledge of revenues of the Oswego Unit System which shall be the only obligation with preference of priority over Oswego’s obligation to the Commission hereunder.

E. General Covenant to Operate Properly. From time to time, Oswego shall take all steps reasonably necessary so that the Oswego Unit System and the Oswego Unit System Connection Facilities may at all times be operated in accordance with industry standards.

F. Accounting and Audit. Oswego shall make and keep proper books and accounts (separate and apart from all other records and accounts of Oswego) in which complete entries shall be made of all transactions relating to the Oswego Unit System, and, within 180 days after the close of each of its fiscal years occurring during the term of this Contract, Oswego shall cause the books and accounts of the Oswego Unit System to be audited annually by independent certified public accountants, showing the receipts and disbursements on account of the Oswego Unit System.

G. Maintain Ownership of Oswego Unit System. Oswego shall construct to completion and thereafter continue to own and possess the Oswego Unit System and, within the exercise of reasonable business judgment and in a manner so as not to cause a default hereunder, shall dispose of property which is part of said System only to the

extent that the Commission consents in writing, which consent shall not be unreasonably withheld. This subsection G does not prohibit Oswego from selling specific equipment that it considers surplus and that is no longer needed or utilized to operate the Oswego Unit System.

H. Insurance. Oswego shall carry insurance or maintain self-insurance with respect to the Oswego Unit System and the Oswego Unit System Connection Facilities of the kinds and in the amounts that are customarily carried or maintained by parties operating similar properties, including, without limiting the generality of the foregoing, fire and other casualty and liability insurance or protection. All moneys received for loss under the insurance policies or on deposit as self-insurance reserves shall be used in making good the loss or damage in respect of which they were paid, whether by repairing the property damaged or replacing the property destroyed, and provision for making good such loss or damage or replacing the property destroyed shall be made within a reasonable time from date of loss. The proceeds derived from any and all policies or available from self-insurance reserves for public liability losses shall be used in paying or reimbursing any accounts from which payments for settlements, judgments, or expenses were advanced.

I. Continue to Serve. Oswego shall use its best efforts to continue serving all customers of the Oswego Unit System within its territorial limits that are intended to be served by the Oswego Unit System as of the date of this Contract.

J. Maintain Water Allocation. Oswego shall use its best efforts to obtain or retain, from time to time, a Water Allocation for the Oswego Unit System at least equal to, but not in excess of two times, the Oswego Unit System's Full Water Requirements

from time to time.

K. Release and Indemnification. To the fullest extent permitted by law, Oswego hereby releases the Commission from, agrees that the Commission shall not be liable for, and agrees to indemnify and hold the Commission harmless from: (1) any liabilities for any loss or damage to property or any injury to, or death of, any person that may be occasioned by or related to any cause whatsoever pertaining to the construction, installation, removal, relocation, replacement, extension, improvement, maintenance, or operation of the Oswego Unit System or the Connection Facilities or (2) any liabilities, losses, or damages, or claims therefor, arising out of the failure, or claimed failure, of Oswego to comply with its covenants or obligations contained in this Contract, including, in each such case, any attorneys' fees. Oswego agrees to indemnify and hold the Commission harmless to the fullest extent permitted by law from any losses, costs, charges, expenses (including attorneys' fees), judgments, and liabilities incurred by the Commission in connection with any action, suit, or proceeding instituted or threatened by any third party in connection with this Contract. If any such claim is asserted, the Commission shall give prompt notice to Oswego and Oswego, if requested by the Commission, shall assume the defense thereof, it being understood, however, that Oswego shall not settle or consent to the settlement of any such claim without the written consent of the Commission.

L. Combining or Separating System Accounts. Oswego shall not combine its waterworks system with its sewerage system or separate its combined waterworks and sewerage system into separate systems unless:

- (i) Oswego shall have provided the Commission with written evidence,

satisfactory to the Commission, that the proposed combination or separation will not materially or adversely affect Oswego's ability to comply with all of the terms, conditions, and covenants of this Contract; and

(ii) The Commission shall have approved such combination or separation in writing.

M. Rate of Withdrawal. Oswego will take Lake Water at the most uniform and continuous rate of withdrawal practical.

N. Emergency Interconnections. No emergency interconnection between the Oswego Unit System and a water distribution system owned and operated by another Contract Customer ("Emergency Interconnection") shall be constructed, operated, or maintained except in accordance with the following terms, conditions, and limitations:

(i) The other Contract Customer and Oswego shall submit to the Commission, for its review and approval, at least 60 days prior to the construction of the Emergency Interconnection or, if the Emergency Interconnection was constructed prior to the execution of this Contract, within 60 days following the execution of this Contract, a report detailing the exact location of the Emergency Interconnection, the manner in which the Emergency Interconnection has been and will be operated and maintained, and the terms of any written or oral agreement for the operation and maintenance of the Emergency Interconnection. Such report shall include as-built drawings of the Emergency Interconnection and exact duplicates of any written agreement for the operation and maintenance of the Emergency Interconnection. The Emergency Interconnection shall not be operated unless and until the Commission shall have approved such report and the Commission shall have received and approved the written agreements required pursuant to clauses (ix) and (xii) of this Subsection 9.N. No approval of such report shall be withheld unless the Emergency Interconnection, or any agreement for the operation and maintenance of the Emergency Interconnection, violate the Contract Customer Contract, this Contract, the Water Supply Contract, or applicable laws or regulations, or pose a threat to the Commission or its Waterworks System.

(ii) The Emergency Interconnection shall be utilized only under emergency conditions unless otherwise approved, in writing, by the

Commission. An emergency condition shall be defined to mean the inability to provide average day flow demands to regular, non-emergency supply customers during a limited period of time due to conditions beyond the control of the party requesting Lake Water. An emergency condition shall not mean any limitation imposed by the Commission on the supply of Lake Water to the other Contract Customer or Oswego specifically related to the other Contract Customer or Oswego pursuant to Section 3 of this Contract or any similar provision of any other water purchase and sale contract, as the case may be, and the Emergency Interconnection shall not be utilized to circumvent the provisions of any agreement approved by the Commission for the Alternate Delivery of Lake Water.

(iii) The Emergency Interconnection shall be maintained in such a manner as at no time to place or threaten to place the Commission or its Waterworks System in jeopardy of failing to meet the terms of the Contract Customer Contract, this Contract, the Water Supply Contract, or the regulations of any agency or governmental authority having jurisdiction over the of a public water supply.

(iv) The party experiencing the emergency condition shall give telephonic notice to the Commission and to the other party of the emergency condition, the expected duration of the emergency condition, and the amount of Lake Water needed, prior to the operation of the Emergency Interconnection. The Emergency Interconnection shall not be operated unless and until the party experiencing the emergency condition shall have given said notice to the Commission.

(v) The party receiving Lake Water through the Emergency Interconnection shall provide daily telephonic notice to the Commission and the party delivering Lake Water for so long as the emergency deliveries continue, and shall provide telephonic notice to the Commission before final shut-off of the emergency flow of Lake Water through the Emergency Interconnection for each such emergency condition.

(vi) The other Contract Customer and Oswego shall keep a joint record of the amount of Lake Water delivered through the Emergency Interconnection, a copy of which shall be provided to the Commission within five days following termination of the use of the Emergency Interconnection for each such emergency condition and, in any case, every five days where the Emergency Interconnection is continuous for more five days.

(vii) The amount of Lake Water delivered to the other Contract Customer's water distribution system or to the Oswego Unit System through the Emergency Interconnection, as the case may be, shall be paid to the Commission directly by the party receiving Lake Water through the Emergency Interconnection at the rates applicable pursuant to, and in accordance with, that party's water purchase and sale contract with the Commission. In case of service curtailment, the other Contract Customer's flow of water through the Emergency Interconnection shall be considered as a portion of the other Contract Customer's allocation from the Commission. In case of service curtailment, Oswego's flow of water through the Emergency Interconnection shall be considered as a portion of Oswego's allocation from the Commission.

(viii) The Commission shall have the right to inspect the Emergency Interconnection, and its operation and maintenance. The Commission shall have the right to install seals or such other devices as the Commission, in its sole and absolute discretion, determines are necessary to determine the operation of the Emergency Interconnection, and all equipment required to be installed to allow the installation of the seals or such other devices shall be installed at Oswego's sole cost and expense.

(ix) The Commission shall bear no responsibility for, and the other Contract Customer and Oswego shall, in writing, release the Commission from, and agree, to the fullest extent permitted by law, that the Commission shall not be liable for, and agree to indemnify and hold the Commission harmless from, any claims, damages, liabilities, and litigation that may be occasioned by, connected with, or in any way related to the construction, operation, and maintenance of the Emergency Interconnection. The other Contract Customer and Oswego shall agree, in writing, to pay all fees, costs, and expenses, including legal and administrative fees, costs, and expenses, incurred by the Commission in defending itself with regard to any and all of the matters mentioned in this Subsection 9.N.

(x) The operation and maintenance of the Emergency Interconnection shall comply in all other respects with the Water Commission Act of 1985, the Contract Customer Contract, this Contract and the Water Supply Contract and the requirements of the Commission thereunder.

(xi) Notwithstanding anything to the contrary contained in any written or oral agreement for the operation and maintenance of the Emergency Interconnection, the Emergency Interconnection shall be operated and maintained only in accordance with this Subsection 9.N and such additional or other terms, conditions, and limitations as the Commission shall impose pursuant to any policy established by the Commission with

respect to emergency interconnections. No such agreement shall be amended, modified, or otherwise changed except upon the prior written approval of the Commission.

(xii) The Commission reserves the right to order all use of the Emergency Interconnection to be discontinued, and the other Contract Customer and Oswego shall agree, in writing, to discontinue such use, at any time the terms, conditions, and limitations of this Subsection 9.N and any such additional or other terms, conditions and limitations imposed by the Commission pursuant to any policy established by the Commission with respect to emergency interconnections are not satisfied.

No emergency interconnection between the Oswego Unit System and a water distribution system owned and operated by any other person, firm, or organization shall be constructed, operated, or maintained except upon the prior written approval of Commission.

SECTION 10. SCHEDULE FOR COMPLETION OF VARIOUS FACILITIES.

A. Plans and Specifications for Oswego Unit System Connection Facilities.

Oswego shall prepare and submit to the Commission for its review and approval, complete detailed plans, specifications, and construction contract documents for the Oswego Unit System Connection Facilities not later than 37 weeks after the effective date of this Contract. The Commission shall provide its comments and revisions to Oswego within 4 weeks after receipt of such documents. Oswego shall incorporate all required changes to such documents within 4 weeks after receipt of the Commission's comments and revisions.

B. IEPA and Other Approvals for Oswego Unit System Connection Facilities.

Oswego shall, within one week after receipt of the Commission's comments and revisions pursuant to Subsection 10.A above, submit such finally revised documents for approval and permitting to the Illinois Environmental Protection Agency (the

“IEPA”) and every other federal, state, or local governmental body having jurisdiction over any element of the Oswego Unit System Connection Facilities, and shall diligently pursue each such approval and permit until it is secured.

C. Commencement of Construction of Oswego Unit System Connection Facilities. Oswego shall cause construction of the Oswego Unit System Connection Facilities to be commenced within 128 weeks after the effective date of this Contract or 69 weeks after receipt of the last approval from any governmental body required as a condition precedent to construction of the Oswego Unit System Connection Facilities, whichever is later. Oswego shall cause construction to be completed within 30 weeks after commencement.

D. Intentionally Omitted.

E. Intentionally Omitted.

F. Intentionally Omitted.

G. Transfer of Property Rights. Oswego shall grant to the Commission all necessary easements for the Commission metering station and other facilities to be constructed pursuant to Subsection 5.A of this Contract within 13 weeks after the effective date of this Contract. Oswego shall, immediately upon execution of this Contract, commence all actions necessary to acquire all property rights not already owned by it necessary to fulfill the requirements of Subsection 5.A of this Contract and this Subsection 10.G.

H. Commencement of Construction of Commission Connection Facilities. The Commission shall cause design of the Commission Connection Facilities to be

commenced within 8 weeks after receipt from Oswego of the preliminary plans and specifications for the Oswego Unit System Connection Facilities satisfactory to the Commission or upon acquisition of all rights of way and other property by Oswego acquired for the installation of the Commission Connection Facilities, whichever is later. The Commission shall cause construction to be completed within 104 weeks after receipt of the last approval from any governmental body required as a condition precedent to construction of the Commission Connection Facilities or May 1, 2028, whichever is later. Oswego acknowledges and agrees, however, that the Commission may, in the exercise of its sole and absolute discretion, accelerate commencement of the design and construction of the Commission Connection Facilities, or completion of construction thereof, without in any way affecting the obligations of Oswego under this Contract, including without limitation Oswego's payment obligations.

I. Delivery of Water for Start-Up Purposes. The Commission shall use its best efforts, consistent with its prior obligations and legal obligations to its customers and consistent with the fair and equitable treatment of all of its Contract Customers, to supply Oswego with Lake Water for pressure testing, disinfecting, and flushing the Oswego Unit System, the Oswego Unit System Connection Facilities, and the required water storage facilities prior to completion of construction if (i) construction of the Oswego Unit System, the Oswego Unit System Connection Facilities, and the required water storage facilities is proceeding in the regular course to completion; (ii) the construction of the Commission Connection Facilities has been completed, other than the SCADA System facilities, to the point where the Commission Connection facilities are capable of serving their intended function or would be capable of serving their

intended function except for the fact that the Oswego Unit System or the Oswego Unit System Connection Facilities are not complete; (iii) such Lake Water is utilized by Oswego solely for purposes of pressure testing, disinfecting, and flushing the Oswego Unit System, the Oswego Unit System Connection Facilities, or the required water storage facilities; and (iv) Oswego pays to the Commission, at the time specified in Subsection 7.H of this Contract, an amount equal to the then current price per 1,000 gallons for Operation and Maintenance Costs times the amount of water, stated in thousands of gallons, actually received from the Commission for such purposes until such time as Oswego first becomes obligated to make payments of Operation and Maintenance Costs pursuant to Subsections 7.A and 7.M of this Contract.

J. Illustrative Schedule of Events. An “Illustrative Schedule of Events” depicting, on the basis of assumptions concerning the length of time necessary to secure various governmental approvals, the sequence of work pursuant to this Section 10 is attached to this Contract as Exhibit F. In the event of any conflict or inconsistency between the provisions of Exhibit F and the provisions of this Section 10, the provisions of this Section 10 shall control.

SECTION 11. ASSIGNABILITY.

Oswego shall not assign or transfer this Contract or any rights or interests herein without the advance written consent of the Commission.

The right to receive all payments that are required to be made by Oswego to the Commission in accordance with the provisions of this Contract may be assigned by the Commission to any Trustee as provided in any Bond Ordinances/Resolutions to secure

the payment of the principal of and the premium, if any, and interest on the Bonds as those amounts come due, subject to the application of those payments as may be provided in any Bond Ordinances/Resolutions. Oswego, upon notice of assignment to any such Trustee, shall make all payments directly to such Trustee. Further, the rights of the Commission to enforce the provisions of this Contract may be assigned to any such Trustee and, in such event, such Trustee shall have the right to enforce this Contract at law or in equity with or without the further consent or participation of the Commission. The Commission also may retain the right to enforce this Contract.

SECTION 12. FORCE MAJEURE.

If, by reason of a force majeure event, either party to this Contract shall be rendered unable wholly or in part to carry out its obligation under this Contract, then if such party shall give notice and full particulars of such force majeure event in writing to the other party within seven (7) days after occurrence of the event or cause relied on, the obligation of the party giving such notice, so far as it is affected by such force majeure event, shall be suspended during the continuance of the inability then claimed, but for no longer period, and any such party shall endeavor to remove or overcome such inability with all reasonable dispatch. The term "force majeure event" as employed herein shall mean acts of God; strikes, lockouts, or other industrial disturbances; acts of a public enemy; orders of any kind of the Government of the United States, of the State of Illinois, or of any civil or military authority; insurrections; riots; epidemics; pandemics; landslides; lightning; earthquakes; fires; hurricanes; storms; floods; washouts; droughts; arrests; restraints of government and people; civil disturbances;

explosions, breakage, or accidents to machinery, pipelines, canals, or tunnels; partial or entire failure of water supply; and inability on the part of the Commission to deliver Lake Water hereunder, or of Oswego to receive Lake Water hereunder, on account of any other causes not reasonably within the control or ability to cure of the party claiming such inability. The settlement of strikes and lockouts shall be entirely within the discretion of the party having the difficulty and the above requirement that any force majeure event shall be remedied with all reasonable dispatch shall not require the settlement of strikes and lockouts by acceding to the demands of the opposing party or parties when such settlement is unfavorable to it in the judgment of the party having the difficulty. No force majeure event which renders either of the parties unable to perform under this Contract shall relieve Oswego of its obligation to make payments to the Commission as required under Section 7 of this Contract and such payments shall continue as if the Oswego Unit System were receiving its Full Water Requirements from the Commission.

SECTION 13. COMMISSION DEFAULTS.

Failure by the Commission to deliver Lake Water to Oswego as required by this Contract or failure of the Commission to perform any other obligation under this Contract, and the continuation of that failure to perform for 30 days after written notice from Oswego to the Commission of such failure, shall be a default of the Commission under this Contract, unless any such failure is excused pursuant to Section 12 of this Contract. If the Commission defaults under this Contract, then Oswego may bring any action against the Commission allowed by law. No Commission default shall relieve

Oswego of its obligation to make payments to the Commission as required under Section 7 of this Contract and such payments shall continue as if the Oswego Unit System were receiving its Full Water Requirements from the Commission.

SECTION 14. OSWEGO OBLIGATION UNCONDITIONAL.

Oswego shall have no right to terminate, cancel, or rescind this Contract; no right to withhold from the Commission or any Trustee who is an assignee of the Commission pursuant to Section 11 of this Contract payments due or to become due under this Contract; no right to recover from the Commission or any such Trustee amounts previously paid under this Contract unless paid in error or contrary to the provisions of this Contract or law; no right of reduction or set-off against the amounts due or to become due under this Contract to the Commission or any such Trustee; and no lien on any amounts in any fund established by the Commission or such Trustee for any reason or on account of the existence or occurrence of any event, condition, or contingency, whether foreseen or unforeseen or foreseeable or unforeseeable by Oswego or the Commission or any other person, including by way of illustration and not limitation by reason of the fact that the Waterworks System in whole or in part is not completed, operable, or operating; or the output of the Waterworks System in whole or in part is suspended, interrupted, interfered with, reduced, or curtailed; or any party to the Water Supply Contract does not perform in whole or in part thereunder; or the Water Allocation of any of the Commission's Contract Customers is modified or terminated or any such Contract Customer does not perform in whole or in part any agreement or instrument, it being the intent hereof that Oswego shall be absolutely and

unconditionally obligated to make all payments under this Contract. The Commission may issue Bonds in specific reliance on the limitations set forth in this Section 14 with respect to the rights of Oswego.

SECTION 15. COOPERATION IN CONSTRUCTION; EASEMENTS.

Oswego shall cooperate with the Commission in the construction and acquisition of the Waterworks System. Oswego is responsible for acquiring all necessary real property and easements within the Village to build the Connection Facilities and shall transfer that insured real property and insured easements to the Commission upon acquisition. Additionally, Oswego, within 30 days after Commission's request therefor, shall grant without charge to the Commission all required construction easements and all insured easements necessary for portions of the Waterworks System to be located on Oswego's property, free and clear of all liens, claims, encumbrances, and restrictions unless otherwise approved by the Commission in writing, provided the Commission agrees to restore the easement property in a reasonable manner after construction. Oswego shall grant the Commission all access to its property necessary to construct and install the Commission Connection Facilities and all other equipment and appurtenant devices to the Point of Delivery.

SECTION 16. COOPERATION IN ISSUANCE OF BONDS.

Oswego shall cooperate with the Commission in the issuance of Bonds. In connection therewith, Oswego shall comply with all reasonable requests of the Commission and shall upon request do as follows:

- A. Make available general and financial information about itself in

accordance with GAAP; and

B. Consent to publication and distribution of its financial information; and

C. Certify that general and financial information about it is accurate, does not contain an untrue statement of a material fact, and does not omit to state a material fact necessary in order to make the statements in that information, in light of the circumstances under which they were made, not misleading; and

D. Make available certified copies of official proceedings; and

E. Provide reasonable certifications to be used in a transcript of closing documents; and

F. Provide and pay for reasonably requested opinions of counsel of its choice as to the validity of its actions taken with respect to, and the binding effect of, this Contract, title to the Oswego Unit System, pending or threatened litigation which could materially affect its performance hereunder, and other reasonably related opinions.

SECTION 17. REGULATORY BODIES.

The Commission and Oswego through this Contract seeks to exercise and maintain all sovereign rights granted to it under and through the Constitution and laws of the State of Illinois. This Contract shall be subject to all valid rules, regulations, and laws applicable hereto passed or promulgated by the United States of America, the State of Illinois, any governmental body or agency having lawful jurisdiction, and any authorized representative or agent of any of them; provided, however, that this clause shall not be construed as waiving the right of either party to challenge the validity of such rule, regulation, or law on any basis, including the impairment of this Contract.

SECTION 18. OTHER WATER SUPPLIERS.

Notwithstanding any of the provisions of this Contract, the Commission is not

prohibited by this Contract from entering into cooperative arrangements with other suppliers or users of Lake Water to provide Lake Water to each other to meet each other's water needs, provided that these arrangements do not interfere, except in emergencies, with the delivery of Lake Water to the Oswego Unit System.

SECTION 19. NOTICES; EVIDENCE OF ACTIONS; WAIVER.

A. Notices. All notices or communications provided for herein shall be in writing and shall be delivered either in person or by United States mail, by certified mail with return receipt requested, postage prepaid, and addressed as follows:

To the Commission:
DuPage Water Commission
600 East Butterfield Road
Elmhurst, IL 60126
Attention: General Manager

To Oswego:
Village of Oswego
100 Parkers Mill
Oswego, IL 60543
Attention: Village Administrator

Copy to:
David J. Silverman
Village Attorney
Mahoney, Silverman, & Cross, LLC
126 South Main Street
Oswego, IL 60543

until and unless other addresses or addressees are specified by notice given in accordance herewith.

B. Evidence of Actions. Any action hereunder to be taken by the Commission or Oswego may be evidenced by copy of official proceedings (including pertinent

minutes, motions, resolutions, or ordinances, as applicable) duly certified by the Clerk of the Commission or the Village Clerk of Oswego.

All notices, demands, requests, consents, approvals, and other instruments required or permitted to be made or given by Oswego pursuant to this Contract shall be in writing, signed by a duly authorized officer, agent, or attorney of Oswego.

C. Waiver. No course of dealing or failure of the Commission or Oswego to enforce strictly any term, right, or condition of this Contract shall be construed as a waiver of such term, right, or condition. No express waiver of any term, right, or condition of this Contract shall operate as a waiver of any other term, right, or condition.

D. Partial Invalidity. If a term or provision of this Contract or the application thereof to any person or circumstances shall, to any extent, be invalid or unenforceable, the remainder of this Contract, or the application of such term or provision to persons or circumstances other than those as to which it is held invalid or unenforceable, shall not be affected thereby, and each such term and provision of this Contract shall be valid and be enforced to the fullest extent permitted by law.

SECTION 20. EFFECTIVE DATE; TERMINATION; PAYMENT OF INTERIM COSTS; TERM.

A. Effective Date. Except for the provisions of Section 10 of this Contract relating to the commencement of certain work following execution of this Contract and except for the provisions of Section 20.C of this Contract relating to the payment of certain costs, as to which provisions this Contract shall be effective immediately after authorization and execution by both parties hereto, this Contract shall be effective

upon authorization and execution by both parties hereto and issuance by the State of Illinois Department of Natural Resources, Office of Water Resources, of a Water Allocation permit to Oswego for each discrete and non-contiguous service area served by the Oswego Unit System.

B. Commission Right to Terminate. If the Oswego Unit System has not been constructed, installed, and completed to a point where it is capable of serving its intended function at the time Oswego first becomes obligated to make payments of Operation and Maintenance Costs pursuant to Subsection 7.M of this Contract, the Commission may, in its sole and absolute discretion, terminate this Contract, in which event the Commission shall give notice to Oswego not less than 20 days in advance of its intention to terminate this Contract and shall provide Oswego an opportunity for a hearing before the Commission prior to the effective date of such termination and, upon the concurrence of a majority of the Commissioners of the Commission following the conclusion of such hearing, this Contract shall be of no further force or effect except for the provisions of Subsection 20.D below, as to which provisions this Contract shall remain in full force and effect.

C. Payment of Interim Costs. Whether or not the Oswego Unit System is ever completed, operable, or operating, Oswego shall pay to the Commission all attorneys', engineering, and administrative fees, costs, and expenses incurred by the Commission for any work related to, or participation in, any regulatory proceeding which shall be required or requested of the Commission by the Illinois Department of Natural Resources, Office of Water Resources, or by Oswego as a result of, or occasioned by,

this Contract and, further, shall pay to the Commission all attorneys', engineering, and administrative fees, costs, and expenses incurred by the Commission in connection with the negotiation, preparation, consideration, and review of this Contract and in implementing the terms of this Contract, including without limitation the costs of the design and construction of the Commission Connection Facilities. If the Oswego Unit System has not been completed as and when required by Subsection 20.B above and the Commission elects, in its sole and absolute discretion, to terminate this Contract pursuant to Subsection 20.B above, then Oswego's payment hereunder shall be due and payable immediately after receipt by it of an invoice from the Commission detailing such costs, after deducting therefrom the amount or amounts of any prepayments made pursuant to Subsection 7.K of this Contract. If the amount or amounts of any such prepayments exceed Oswego's payment obligation hereunder, the Commission shall refund the difference to Oswego. If either (i) the Oswego Unit System is completed as and when required by Subsection 20.B above or (ii) if not completed, the Commission does not elect to terminate this Contract, then such costs shall be treated as part of the Connection Facilities Cost provided in Subsection 7.C of this Contract.

D. Term. Unless this Contract is sooner terminated by the Commission pursuant to Subsection 20.B above, this Contract shall continue in force and effect until February 24, 2064.

SECTION 21. GOVERNING LAW AND VENUE.

This Contract shall be construed exclusively under the applicable laws, but not the

conflicts of laws rules, of the State of Illinois. The parties agree that venue for any litigation arising out of this Contract shall only be proper in the Eighteenth Judicial Circuit Court, DuPage County, Illinois and waive any right, whether statutory or otherwise, to venue in any other jurisdiction.

SECTION 22. MUNICIPAL BOUNDARIES.

Not later than 365 days after the execution of this Contract, Oswego shall provide the Commission with: (i) a current list of all parcels within Oswego's corporate limits, identified by Property Index Number and common address, (ii) a correct, complete legal description of the entire boundary of the municipality, and (iii) an aerial photograph depicting the entire boundary of the Oswego municipal limits. Oswego shall update the information in this Section 22 within 60 days of any changes in its municipal boundaries.

SECTION 23. MODIFICATIONS OR AMENDMENTS.

This Contract shall not be modified or amended in any way except in writing approved by both parties hereto. No such modification or amendment shall materially impair or adversely affect the ability or obligation of Oswego to make payments to the Commission to meet the Commission's obligations under the Water Supply Contract, the Contract Customer Contract, and the Bond Ordinances/Resolutions.

SECTION 24. EXHIBITS INCORPORATED.

Exhibits A, B-1, B-2, C, D, E, F, and G to this Contract are hereby fully incorporated into this Contract as substantive provisions of this Contract.

SECTION 25. EXECUTION IN COUNTERPARTS.

This Contract shall be executed in two counterparts, each of which shall be deemed to

be an original, and each of which shall constitute but one and the same instrument.

[SIGNATURE PAGE FOLLOWS]

IN WITNESS WHEREOF, the parties hereto have caused their respective corporate names to be subscribed hereto and their respective corporate seals to be affixed hereto and attested by their duly authorized officers, all on the date set opposite their respective corporate names.

Date: 10/3/24

VILLAGE OF OSWEGO

By: 
Ryan Kauffman - President

ATTEST:

Tina Touchette - Village Clerk

Date: _____

DUPAGE WATER COMMISSION

By: _____
James F. Zay - Chairman

ATTEST:

Danna M. Mundall - Clerk

EXHIBIT A
OSWEGO UNIT SYSTEM

Village of Oswego
Water Purchase and Sale Contract

EXHIBIT A
OSWEGO UNIT SYSTEM

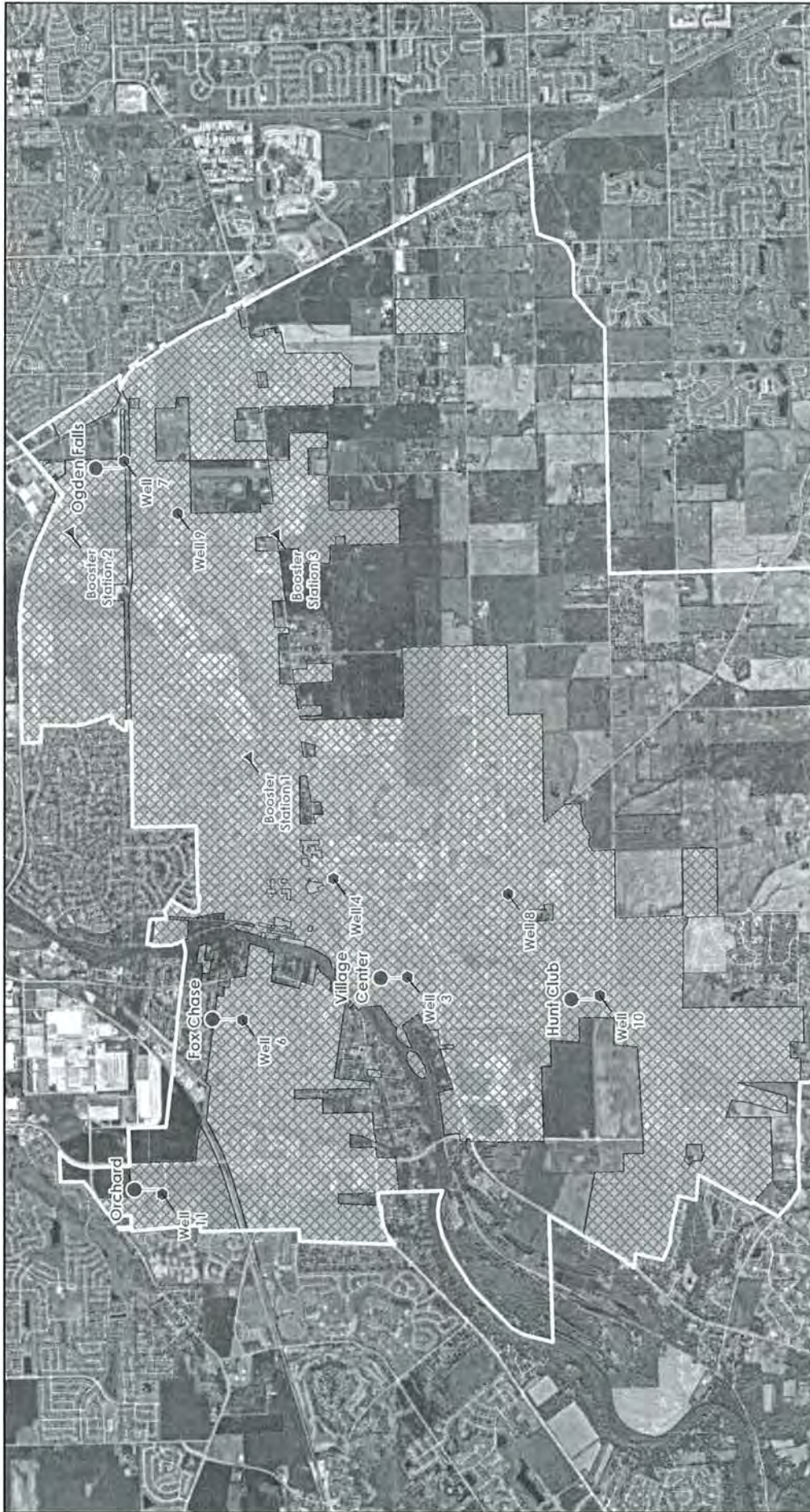

Village of Oswego Water Service Area

This map was prepared by the Village of Oswego GIS Division. It is intended to provide a general overview of the water service area and is not intended to be used for legal purposes. The Village of Oswego is not responsible for any errors or omissions in this map. For more information, please contact the Village of Oswego GIS Division at (315) 339-1234.

Village of Oswego GIS Division, Nearmap.com
 Date: 9/16/2024



- ▲ Booster Station
- Production Well
- Water Tower
- Village of Oswego Water Service Area
- Village of Oswego Corporate Boundary
- Planning Boundary

EXHIBIT B-1
OSWEGO UNIT SYSTEM CONNECTION FACILITIES

Village of Oswego
Water Purchase and Sale Contract

EXHIBIT B-1
OSWEGO UNIT SYSTEM CONNECTION FACILITIES-MS 32A SITE

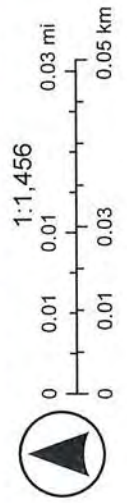
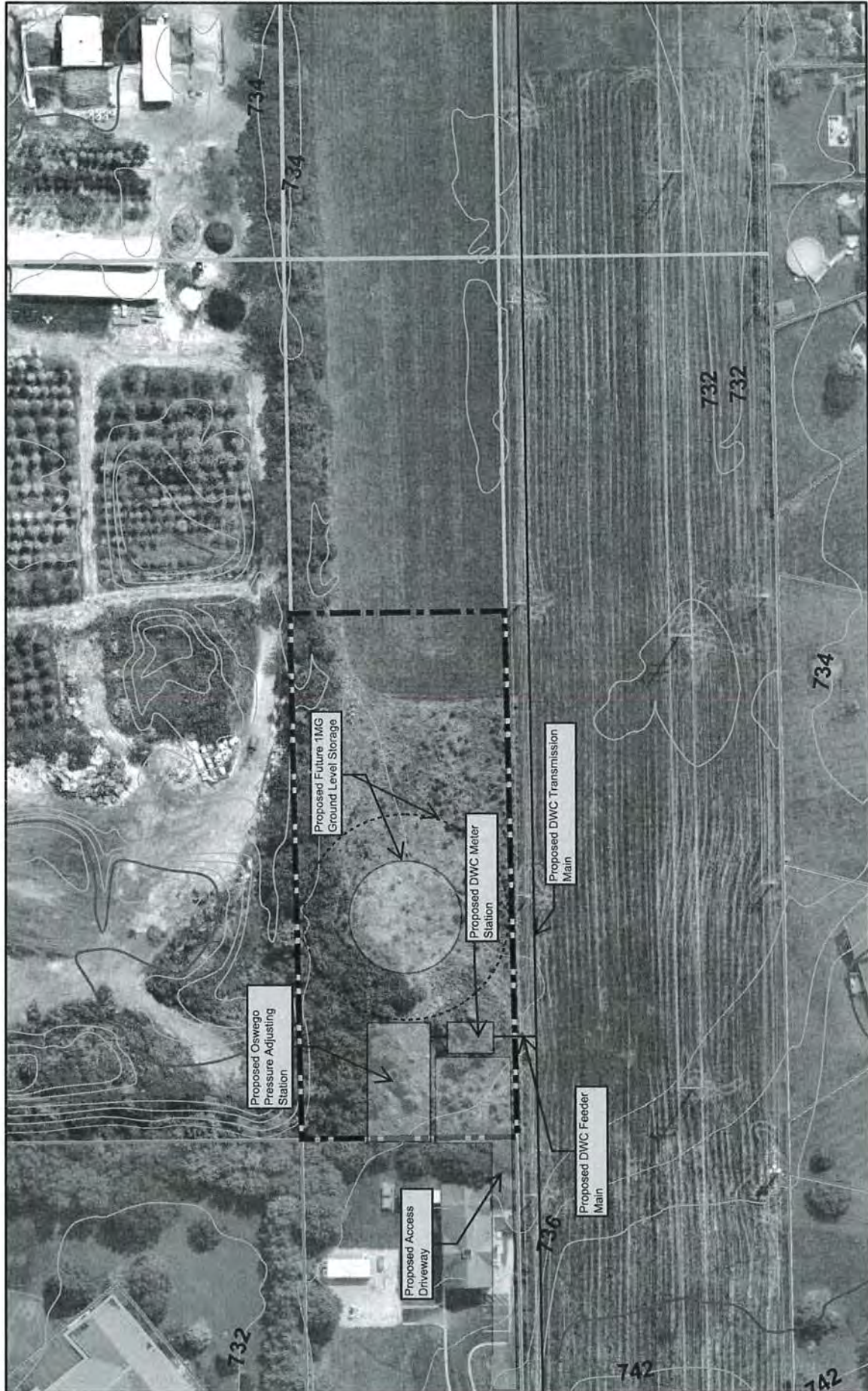

EXHIBIT B-1
OSWEGO UNIT SYSTEM CONNECTION FACILITIES
MS 32B SITE

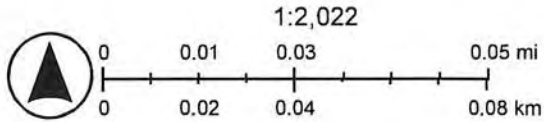

EXHIBIT B-1
OSWEGO UNIT SYSTEM CONNECTION FACILITIES
MS 32C SITE

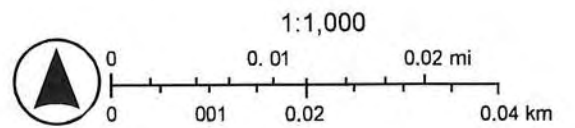

EXHIBIT B-1

WATER DELIVERY DATA

DU PAGE WATER COMMISSION

Date: August 8, 2023 (data provided by Oswego consultant)

CUSTOMER NAME Village of Oswego

DELIVERY POINT (DWC NODE No.) MS 32A

TYPE OF CUSTOMER PAS FACILITY REQUIRED Rate Control Type D

LOCATION AT 378 Ogden Falls Boulevard, Oswego, IL (Ogden Falls Tower)

DWC DESIGN MINIMUM HYDRAULIC GRADE* (USGS DATUM) 844

CUSTOMER'S SYSTEM OVERFLOW ELEV. AND/OR REQUIRED HEAD** 892

CUSTOMER'S STORAGE FACILITY 1.5 MG Elevated (1.0 MG Ground Storage Planned)

HYDRAULIC DATA

	Flow Rate @ Customer's Facility MGD	DWC Hydraulic Grade 10 ft. Downstream of DWC Meter Station USGS Datum
<u>2028 Avg. Day</u>	<u>0.30 MGD</u>	<u>880</u>
<u>2028 Max. Day</u>	<u>0.51 MGD</u>	<u>898</u>
<u>2050 Avg. Day</u>	<u>0.55 MGD</u>	<u>844</u>
<u>2050 Max. Day</u>	<u>0.93 MGD</u>	<u>886</u>
<u>2050 Peak***</u>	<u>1.65 MGD</u>	

* DWC design minimum hydraulic grade will fluctuate approx. \pm 10 feet depending upon Commission's elevated storage water elevation.

** It is customer's responsibility to verify the system overflow elevation or required head.

*** 3 x 2050 average day flow or 1500 GPM minimum.

EXHIBIT B-1

WATER DELIVERY DATA
DU PAGE WATER COMMISSION

Date: August 8, 2023 (data provided by Oswego consultant)

CUSTOMER NAME Village of Oswego

DELIVERY POINT (DWC NODE No.) MS 32B

TYPE OF CUSTOMER PAS FACILITY REQUIRED Rate Control Type D

LOCATION AT 700 Cole Avenue, Oswego, IL (Hunt Club Tower)

DWC DESIGN MINIMUM HYDRAULIC GRADE* (USGS DATUM) 829

CUSTOMER'S SYSTEM OVERFLOW ELEV. AND/OR REQUIRED HEAD** 837

CUSTOMER'S STORAGE FACILITY 1.5 MG Elevated

HYDRAULIC DATA

	Flow Rate @ Customer's Facility MGD	DWC Hydraulic Grade 10 ft. Downstream of DWC Meter Station USGS Datum
<u>2028</u> Avg. Day	<u>2.06 MGD</u>	<u>877</u>
<u>2028</u> Max. Day	<u>3.50 MGD</u>	<u>896</u>
<u>2050</u> Avg. Day	<u>2.78 MGD</u>	<u>829</u>
<u>2050</u> Max. Day	<u>4.73 MGD</u>	<u>878</u>
<u>2050</u> Peak***	<u>8.35 MGD</u>	

* DWC design minimum hydraulic grade will fluctuate approx. \pm 10 feet depending upon Commission's elevated storage water elevation.

** It is customer's responsibility to verify the system overflow elevation or required head.

*** 3 x 2050 average day flow or 1500 GPM minimum.

EXHIBIT B-1

WATER DELIVERY DATA

DU PAGE WATER COMMISSION

Date: August 8, 2023 (data provided by Oswego consultant)

CUSTOMER NAME Village of Oswego

DELIVERY POINT (DWC NODE No.) MS 32C

TYPE OF CUSTOMER PAS FACILITY REQUIRED Pressure Reducing Type B

LOCATION AT 6701 Tuscany Trail, Oswego, IL (Orchard Rd Tower)

DWC DESIGN MINIMUM HYDRAULIC GRADE* (USGS DATUM) 879

CUSTOMER'S SYSTEM OVERFLOW ELEV. AND/OR REQUIRED HEAD** 788

CUSTOMER'S STORAGE FACILITY 1.5 MG Elevated

HYDRAULIC DATA

	Flow Rate @ Customer's Facility MGD	DWC Hydraulic Grade 10 ft. Downstream of DWC Meter Station USGS Datum
<u>2028</u> Avg. Day	<u>0.45 MGD</u>	<u>879-898</u>
<u>2028</u> Max. Day	<u>0.75 MGD</u>	
<u>2050</u> Avg. Day	<u>0.45 MGD</u>	
<u>2050</u> Max. Day	<u>0.75 MGD</u>	<u>842-885</u>
<u>2050</u> Peak***	<u>1.35 MGD</u>	

* DWC design minimum hydraulic grade will fluctuate approx. \pm 10 feet depending upon Commission's elevated storage water elevation.

** It is customer's responsibility to verify the system overflow elevation or required head.

*** 3 x 2050 average day flow or 1500 GPM minimum.

EXHIBIT B-1

PRELIMINARY PLANS FOR THE OSWEGO
UNIT SYSTEM CONNECTION FACILITIES

MINIMUM REQUIREMENTS FOR PRESSURE ADJUSTING (PA) STATIONS
AND SCHEMATICS

1. Rate Controllers shall be adjusted and the water distribution shall otherwise be operated to take a normally uniform flow rate from the DWC system. The maximum hourly rate should in no case be greater than 1.7 times the average annual hourly rate based on the current Lake Michigan water allocation for the PA station. The adequacy of customer system storage and proper operation of storage facilities to assure uniform take-off is the customer's responsibility.
2. Designs shall provide for the appropriate fluctuation of customer storage facility levels to assure uniform take-off. Elevated storage tanks shall be fluctuated appropriately during sub freezing conditions.
3. Emergency bypass lines, flow rate controllers and system isolation check valves shall be required in all designs.
4. Altitude valves or other appropriate means for preventing elevated and ground storage tank overflows are recommended if such provisions do not already exist in the customer's system.
5. Surge relief facilities for protection of both the customer and DWC facilities shall be required.
6. the type and design of the PA station will be dependent upon:
 - a. The difference between, (i) the minimum DWC system pressure (hydraulic grade) 10 feet downstream of the DWC Metering Station (MS) and, (ii) the customer's elevated tank overflow or system pressure.
 - b. Whether ground storage will be used to receive water at the PA station.

In general, the recommended design types for the various receiving facility designs and the differential between the minimum DWC system grade (at the point of delivery) and the customer system elevated tank overflows or system pressure are as follows:

<u>Design Type</u>	<u>Head (DWC – Customer)</u>
Pressure Reducing (Type A & B)	> / = 28 feet
Rate Control (Type C)	< 28 feet & >= 0 feet
Pressure Increasing (Type D)	< 0 feet

EXHIBIT B-1

PRELIMINARY PLANS FOR THE OSWEGO UNIT SYSTEM CONNECTION FACILITIES

7. Where pumping stations are required (Type D), each station shall be equipped with three (3) pumping units of equal size. Each unit shall have rated capacity of approximately equal to the average day, year 2020 flow, at the station. Two (2) pumping units shall have a combined capacity to provide maximum day, year 2020 flow (1.7 times average day year 2020 flow). The third unit is for standby. A fourth space is shown on the pumping station (Type D) schematic for an additional pumping unit at the customer's option.
8. The facility requirements indicated are for illustrative purposes showing general guidelines and various design functions to be provided. Each station shall be designed and proper equipment shall be selected to meet local and specific conditions.
9. Emergency conditions may permit three (3) times average day flow at the PA based on the year 2020 Lake Michigan Water Allocation or 1500 GPM, whichever is greater.
10. The Commission will only provide a chlorine residual meeting State and Federal Standards at the point of delivery. Additional chlorination facilities, if required, shall be provided by the customer at the customer's expense.

EXHIBIT B-1 OSWEGO UNIT SYSTEM CONNECTION FACILITIES

PRESSURE REDUCING STATION - TYPE A

- 1) HOURLY FLOWS SHALL BE UNIFORM THROUGHOUT EACH DAY* AND RATE NOT EXCEED 1.7 X AVERAGE DAY FLOW AT THE STATION BASED ON CURRENT YEAR LAKE MICHIGAN WATER ALLOCATION.
- 2) PRESSURE REDUCING STATION IS REQUIRED IF THE COMMISSION'S SYSTEM DESIGN PRESSURE** EXCEEDS THE DESIRED CUSTOMER'S SYSTEM PRESSURE BY TWELVE (12) P.S.I. (28 FT.) OR MORE.
- 3) PRESSURE REDUCING STATION TYPE A - CONNECTIONS TO GROUND RESERVOIR AND SYSTEM.
 - A. PRESSURE REDUCING AND CHECK VALVE, AND RATE CONTROLLER (MAXIMUM FLOW LIMIT CONTROL) ARE REQUIRED.
 - B. PRESSURE RELIEF FOR BOTH DWC AND CUSTOMER'S SYSTEM IS REQUIRED.
 - C. EMERGENCY BYPASS IS REQUIRED.
 - D. ALTITUDE VALVE WITH PRESSURE SUSTAINING FUNCTION AND BYPASS (CUSTOMER'S RESPONSIBILITY) ARE RECOMMENDED FOR GROUND RESERVOIR CONNECTION. PROPER DAILY USE OF THE RESERVOIR IS REQUIRED.
 - E. CHLORINATION SYSTEM IS OPTIONAL (CUSTOMER'S RESPONSIBILITY).
- 4) EMERGENCY CONDITIONS MAY PERMIT 3X AVERAGE DAY FLOW AT THE STATION BASED ON 2020 LAKE MICHIGAN WATER ALLOCATION OR 1500 GPM WHICHEVER IS LARGER.
- 5) STANDBY PRESSURE REDUCING AND CHECK VALVE ARE REQUIRED.
- 6) THE FACILITY REQUIREMENTS INDICATED ARE FOR ILLUSTRATIVE PURPOSE SHOWING GENERAL GUIDELINES AND VARIOUS DESIGN FUNCTIONS TO BE PROVIDED. EACH STATION SHALL BE DESIGNED, AND PROPER EQUIPMENT SHALL BE SELECTED TO MEET LOCAL CONDITIONS AND SITE SPECIFICS.

*ACCOMPLISHED BY SETTING RATE CONTROLLER IN ACCORDANCE WITH THE CUSTOMER DEMAND.

**DESIGN PRESSURE WILL FLUCTUATE APPROXIMATELY + 10 FEET DEPENDING UPON COMMISSION'S ELEVATED STORAGE WATER ELEVATION.

SCHEMATIC OF PRESSURE REDUCING STATION TYPE A

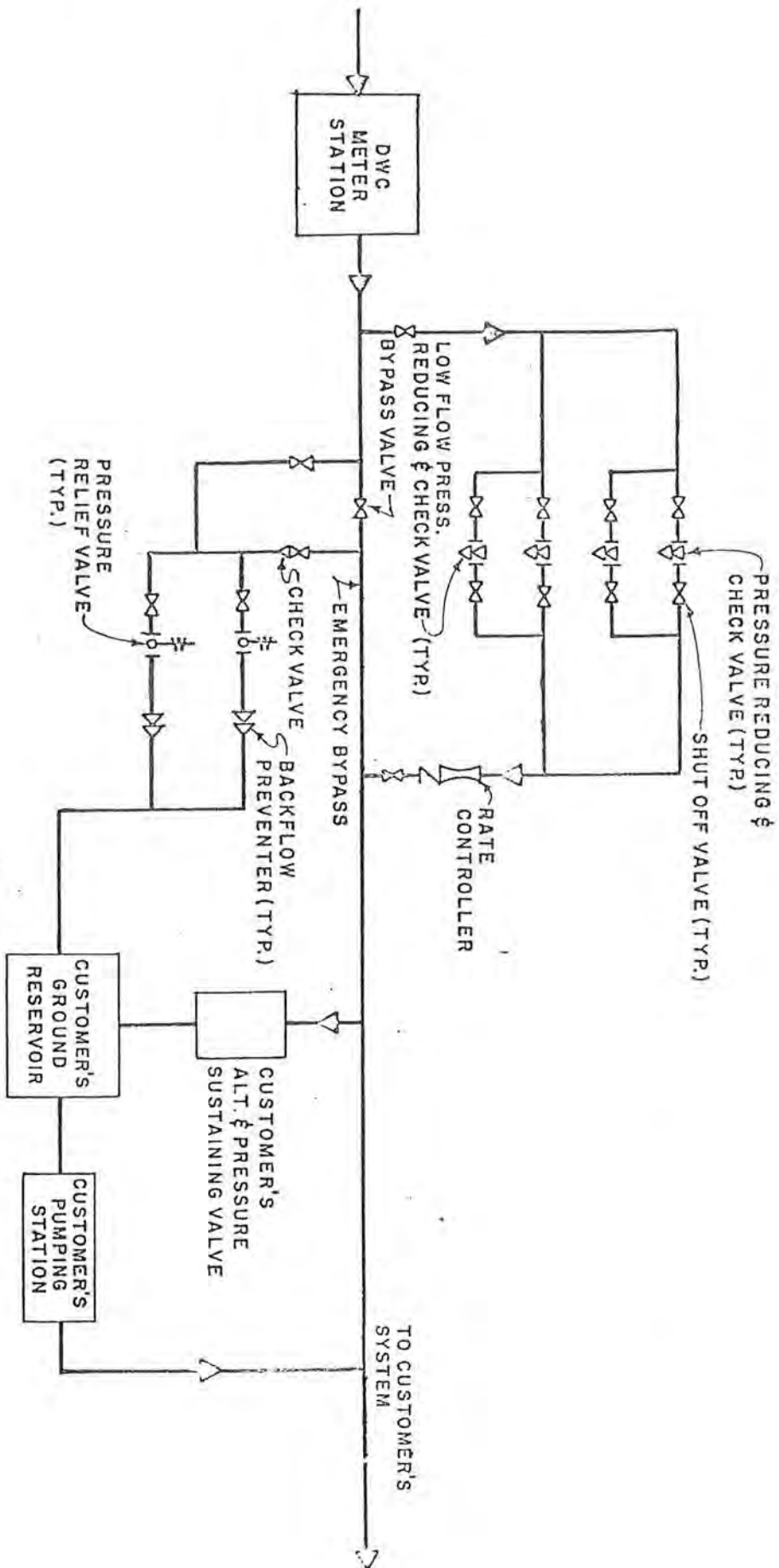

DUPAGE WATER COMMISSION
DATE:

ALVORD, BURDICK & HOWSON
ENGINEERS
CHICAGO

EXHIBIT B-1 OSWEGO UNIT SYSTEM CONNECTION FACILITIES

PRESSURE REDUCING STATION - TYPE B

- 1) HOURLY FLOWS SHALL BE UNIFORM THROUGHOUT EACH DAY* AND RATE NOT EXCEED 1.7 X AVERAGE DAY FLOW AT THE STATION BASED ON CURRENT YEAR LAKE MICHIGAN WATER ALLOCATION.
- 2) PRESSURE REDUCING STATION IS REQUIRED IF THE COMMISSION'S SYSTEM DESIGN PRESSURE** EXCEEDS THE DESIRED CUSTOMER'S SYSTEM PRESSURE BY TWELVE (12) P.S.I. (28 FT.) OR MORE.
- 3) PRESSURE REDUCING STATION TYPE B - CONNECTIONS TO ELEVATED TANK AND SYSTEM.
 - A. PRESSURE REDUCING AND CHECK VALVE, AND RATE CONTROLLER (MAXIMUM FLOW LIMIT CONTROL) ARE REQUIRED.
 - B. PRESSURE RELIEF FOR BOTH DWC AND CUSTOMER'S SYSTEM IS REQUIRED.
 - C. EMERGENCY BYPASS IS REQUIRED.
 - D. ALTITUDE VALVE WITH BYPASS (CUSTOMER'S RESPONSIBILITY) IS RECOMMENDED FOR ELEVATED TANK CONNECTION. PROPER DAILY USE OF THE TANK IS REQUIRED.
 - E. CHLORINATION SYSTEM IS OPTIONAL (CUSTOMER'S RESPONSIBILITY).
- 4) EMERGENCY CONDITIONS MAY PERMIT 3X AVERAGE DAY FLOW AT THE STATION BASED ON 2020 LAKE MICHIGAN WATER ALLOCATION OR 1500 GPM WHICHEVER IS LARGER.
- 5) STANDBY PRESSURE REDUCING AND CHECK VALVE ARE REQUIRED.
- 6) THE FACILITY REQUIREMENTS INDICATED ARE FOR ILLUSTRATIVE PURPOSE SHOWING GENERAL GUIDELINES AND VARIOUS DESIGN FUNCTIONS TO BE PROVIDED. EACH STATION SHALL BE DESIGNED, AND PROPER EQUIPMENT SHALL BE SELECTED TO MEET LOCAL CONDITIONS AND SITE SPECIFICS.

*ACCOMPLISHED BY SETTING RATE CONTROLLER IN ACCORDANCE WITH THE CUSTOMER DEMAND.

**DESIGN PRESSURE WILL FLUCTUATE APPROXIMATELY + 10 FEET DEPENDING UPON COMMISSION'S ELEVATED STORAGE WATER ELEVATION.

SCHEMATIC OF PRESSURE REDUCING STATION TYPE B

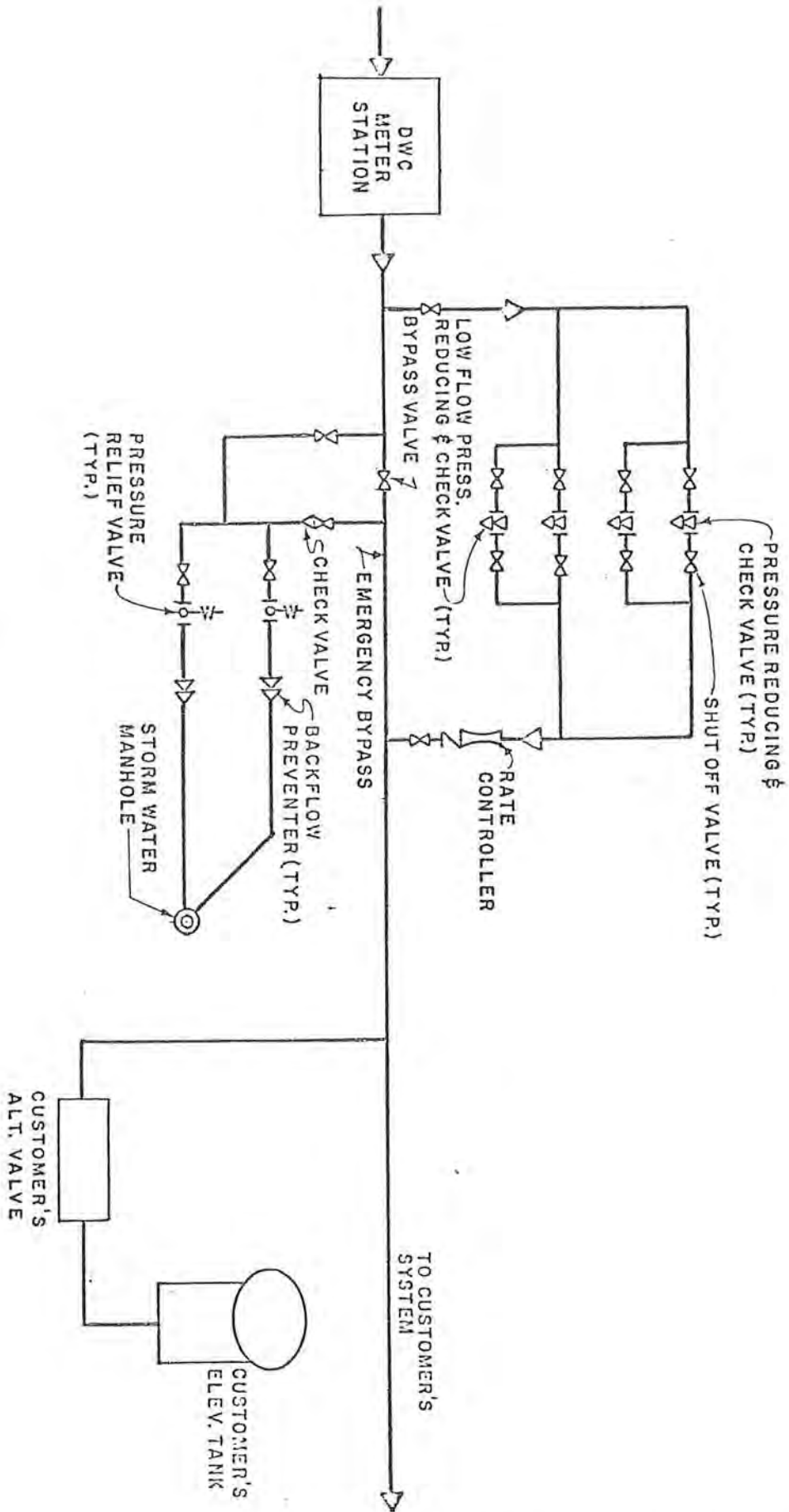

DUPAGE WATER COMMISSION
DATE:

ALVORD, BURDICK & HOWSON
ENGINEERS CHICAGO

EXHIBIT B-1 OSWEGO UNIT SYSTEM CONNECTION FACILITIES

PRESSURE REDUCING STATION - TYPE C

- 1) HOURLY FLOWS SHALL BE UNIFORM THROUGHOUT EACH DAY* AND RATE NOT EXCEED 1.7 X AVERAGE DAY FLOW AT THE STATION BASED ON CURRENT YEAR LAKE MICHIGAN WATER ALLOCATION.
- 2) PRESSURE REDUCING STATION IS REQUIRED IF THE COMMISSION'S SYSTEM DESIGN PRESSURE** EXCEEDS THE DESIRED CUSTOMER'S SYSTEM PRESSURE BY TWELVE (12) P.S.I. (28 FT.) OR MORE.
- 3) PRESSURE REDUCING STATION TYPE C - DIRECT CONNECTIONS TO DISTRIBUTION SYSTEM.
 - A. ALL DIRECT CONNECTIONS FROM DUPAGE WATER COMMISSION FEEDER MAIN TO DISTRIBUTION SYSTEM SHALL REQUIRED DWC APPROVAL.
 - B. MAXIMUM HOUR TAKE-OFF RATE SHALL BE REGULATED TO COMPLY WITH ITEM 1) REQUIREMENTS. ADEQUACY OF STORAGE CAPACITY IS CUSTOMER'S RESPONSIBILITY.
 - C. PRESSURE REDUCING AND CHECK VALVE, AND RATE CONTROLLER (MAXIMUM FLOW LIMIT CONTROL) ARE REQUIRED.
 - D. PRESSURE RELIEF FOR BOTH DWC AND CUSTOMER'S SYSTEM IS REQUIRED.
 - E. EMERGENCY BYPASS IS REQUIRED.
 - F. ALTITUDE VALVE WITH BYPASS (AND PRESSURE SUSTAINING FUNCTION FOR GROUND STORAGE) IS RECOMMENDED FOR STORAGE CONNECTION (CUSTOMER'S RESPONSIBILITY). PROPER DAILY USE OF THE STORAGE IS REQUIRED.
 - G. CHLORINATION SYSTEM IS OPTIONAL (CUSTOMER'S RESPONSIBILITY).
- 4) EMERGENCY CONDITIONS MAY PERMIT 3X AVERAGE DAY FLOW AT THE STATION BASED ON 2020 LAKE MICHIGAN WATER ALLOCATION OR 1500 GPM WHICHEVER IS LARGER.
- 5) STANDBY PRESSURE REDUCING AND CHECK VALVE ARE REQUIRED.
- 6) THE FACILITY REQUIREMENTS INDICATED ARE FOR ILLUSTRATIVE PURPOSE SHOWING GENERAL GUIDELINES AND VARIOUS DESIGN FUNCTIONS TO BE PROVIDED. EACH STATION SHALL BE DESIGNED, AND PROPER EQUIPMENT SHALL BE SELECTED TO MEET LOCAL CONDITIONS AND SITE SPECIFICS.

*ACCOMPLISHED BY SETTING RATE CONTROLLER IN ACCORDANCE WITH THE CUSTOMER DEMAND.

**DESIGN PRESSURE WILL FLUCTUATE APPROXIMATELY + 10 FEET DEPENDING UPON COMMISSION'S ELEVATED STORAGE WATER ELEVATION.

SCHEMATIC OF PRESSURE REDUCING STATION TYPE C

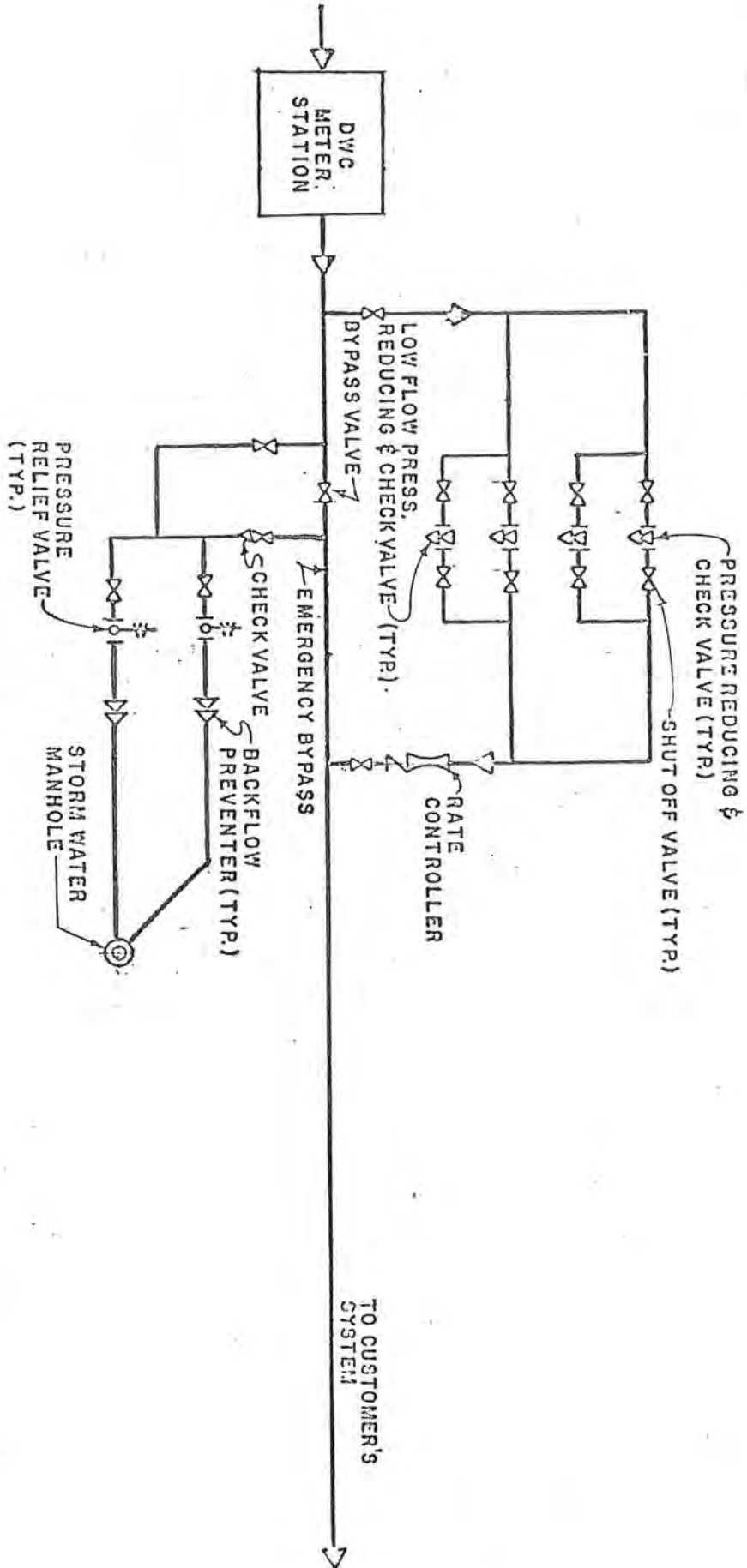

DU PAGE WATER COMMISSION
DATE:

ALVORD, BURDICK & HOWSON
ENGINEERS CHICAGO

EXHIBIT B-1 OSWEGO UNIT SYSTEM CONNECTION FACILITIES

RATE CONTROL STATION - TYPE D

- 1) HOURLY FLOWS SHALL BE UNIFORM THROUGHOUT EACH DAY* AND RATE NOT EXCEED 1.7 X AVERAGE DAY FLOW AT THE STATION BASED ON CURRENT YEAR LAKE MICHIGAN WATER ALLOCATION.
- 2) RATE CONTROL STATION IS REQUIRED IF THE DIFFERENCE BETWEEN THE COMMISSION'S MINIMUM DESIGN PRESSURE** AND THE CUSTOMER'S DESIRED SYSTEM PRESSURE IS NOT MORE THAN TWELVE (12) P.S.I. (28 FT.).
- 3) RATE CONTROL STATION TYPE D - CONNECTIONS TO ELEVATED TANK AND SYSTEM.
 - A. PRESSURE SUSTAINING AND CHECK VALVE, AND RATE CONTROLLER (MAXIMUM FLOW LIMIT CONTROL) ARE REQUIRED.
 - B. PRESSURE RELIEF FOR BOTH DWC AND CUSTOMER'S SYSTEM IS REQUIRED.
 - C. EMERGENCY BYPASS IS REQUIRED.
 - D. ALTITUDE VALVE WITH BYPASS (CUSTOMER'S RESPONSIBILITY) IS RECOMMENDED FOR ELEVATED TANK CONNECTION. PROPER DAILY USE OF THE TANK IS REQUIRED.
 - E. CHLORINATION SYSTEM IS OPTIONAL (CUSTOMER'S RESPONSIBILITY).
- 4) EMERGENCY CONDITIONS MAY PERMIT 3X AVERAGE DAY FLOW AT THE STATION BASED ON 2020 LAKE MICHIGAN WATER ALLOCATION OR 1500 GPM WHICHEVER IS LARGER.
- 5) STANDBY PRESSURE SUSTAINING AND CHECK VALVE ARE REQUIRED.
- 6) THE FACILITY REQUIREMENTS INDICATED ARE FOR ILLUSTRATIVE PURPOSE SHOWING GENERAL GUIDELINES AND VARIOUS DESIGN FUNCTIONS TO BE PROVIDED. EACH STATION SHALL BE DESIGNED, AND PROPER EQUIPMENT SHALL BE SELECTED TO MEET LOCAL CONDITIONS AND SITE SPECIFICS.

*ACCOMPLISHED BY SETTING RATE CONTROLLER IN ACCORDANCE WITH THE CUSTOMER DEMAND.

**DESIGN PRESSURE WILL FLUCTUATE APPROXIMATELY + 10 FEET DEPENDING UPON COMMISSION'S ELEVATED STORAGE WATER ELEVATION.

SCHEMATIC OF PRESSURE INCREASING STATION TYPE D

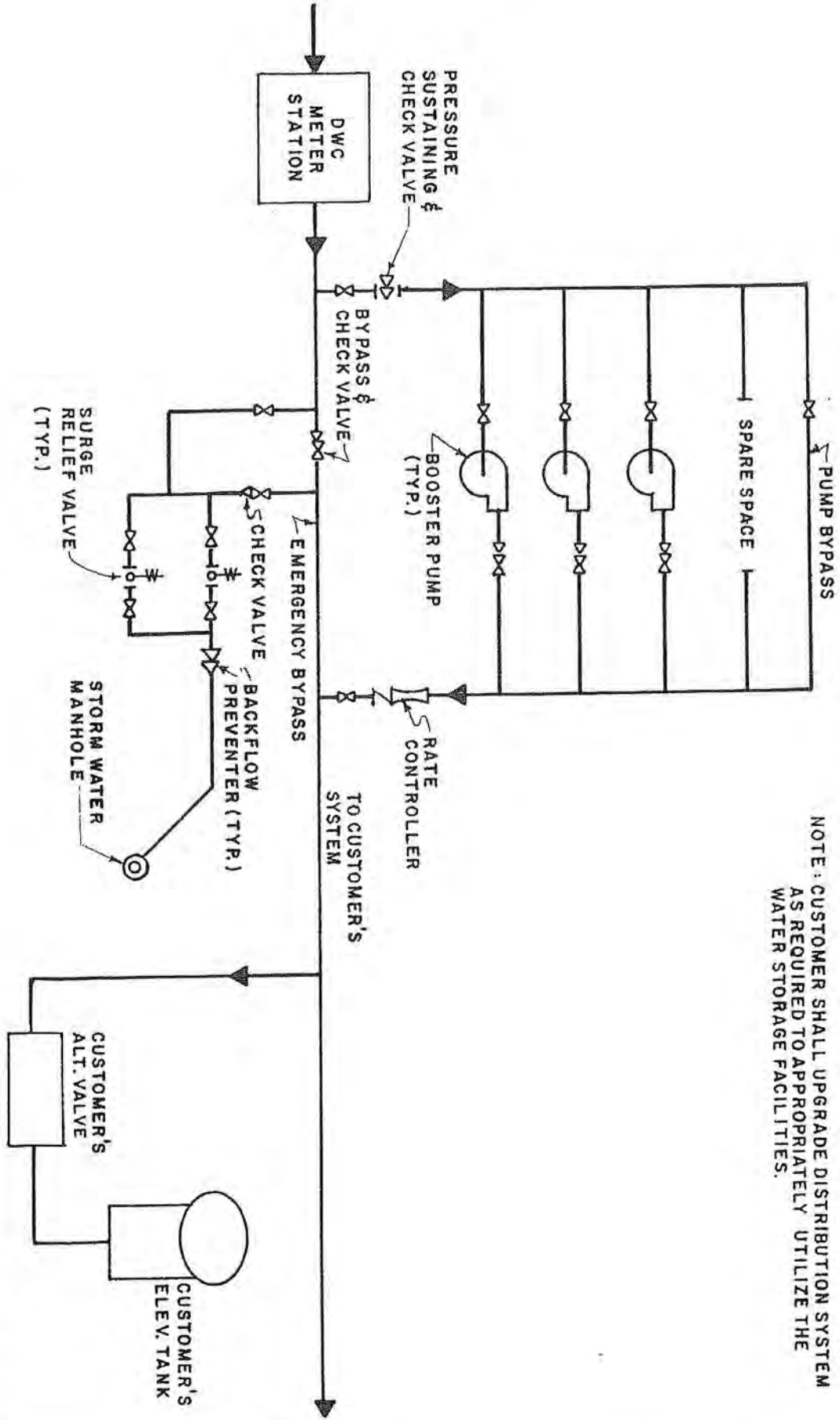

NOTE: CUSTOMER SHALL UPGRADE DISTRIBUTION SYSTEM AS REQUIRED TO APPROPRIATELY UTILIZE THE WATER STORAGE FACILITIES.

DU PAGE WATER COMMISSION
DATE: 12-17-87

ALVORD, BURDICK & HOWSON
ENGINEERS CHICAGO

EXHIBIT B-2
COMMISSION CONNECTION FACILITIES

Village of Oswego
Water Purchase and Sale Contract

EXHIBIT B-2 COMMISSION CONNECTIONS FACILITIES

TYPICAL 2 TRAIN METER STATION LAYOUT

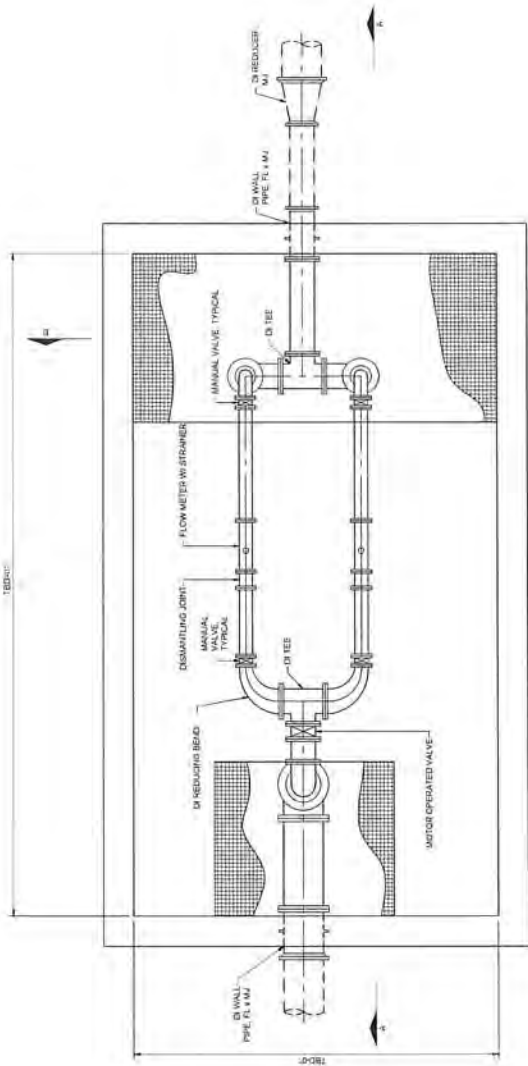

PLAN VIEW

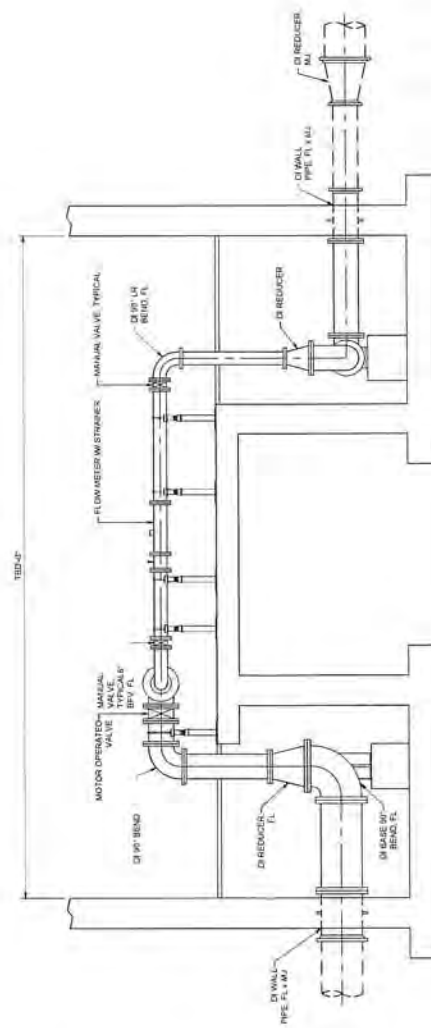

SECTION A-A

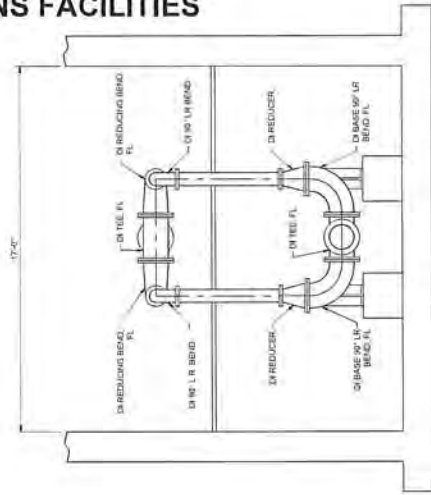

SECTION B-B

TYPICAL 2-TRAIN
DMC METER STATION
PRELIMINARY PIPING LAYOUT

DUPAGE WATER COMMISSION
WATERLINK EXTENSION



DESIGNED	MJD
CHECKED	AWG
DRAWN	RSE
CHECKED	DS

REV.	DATE	DESCRIPTION

DATE	SEPT 2011
SCALE	NONE
PROJECT NO.	12P-1031200



LSN
Professional Engineering
1000 North Lake Street
Chicago, IL 60610
Tel: 312.467.1000
Fax: 312.467.1001
www.lsn.com

DRAWING NO.
D-101
SHEET NO.
1 of 2

EXHIBIT B-2 COMMISSION CONNECTION FACILITIES

TYPICAL 3-TRAIN METER STATION LAYOUT

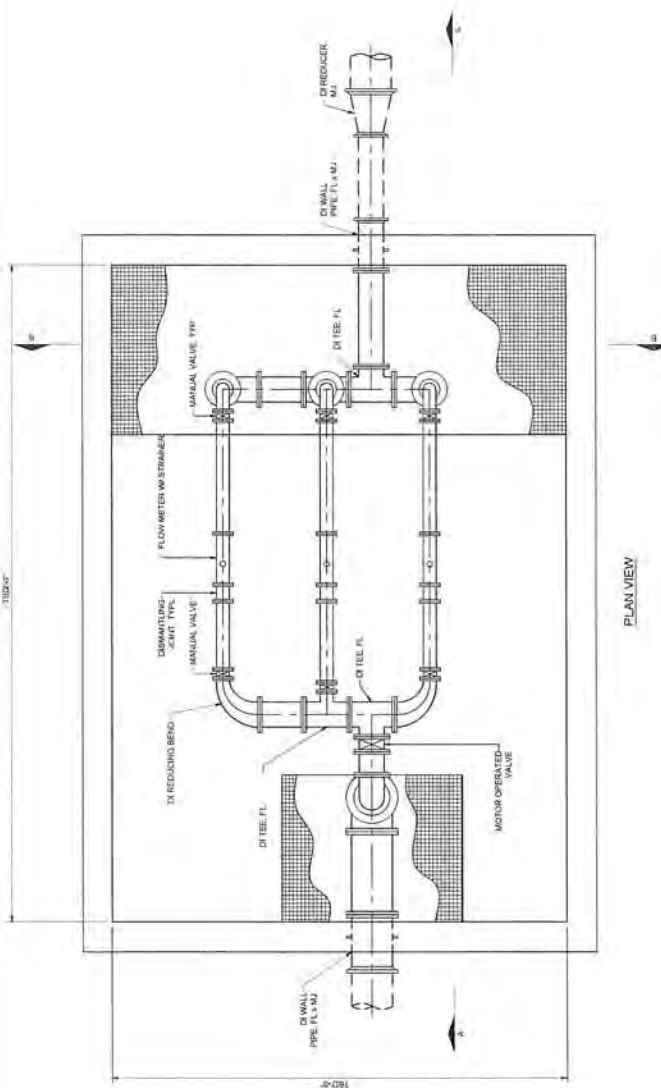

PLAN VIEW

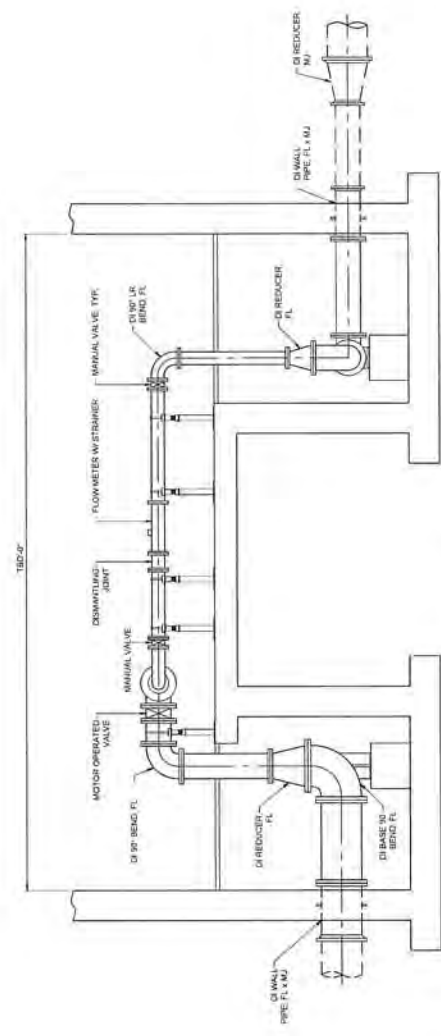

SECTION A-A

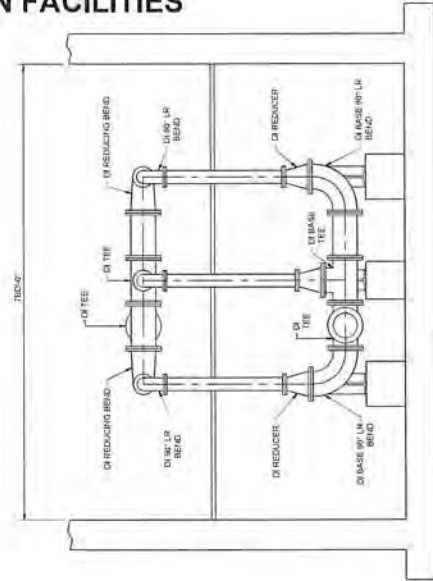

SECTION B-B

REV. DATE	DESCRIPTION	BY	DATE	DESIGNED -	MADE	CHECKED -	AWD
				SCALE -	NONE	DRAWN -	GSZ
				PROJECT NO. -	124-10031-001	CHECKED -	GSZ
				TYPICAL 3-TRAIN DUC METER STATION PRELIMINARY PIPING LAYOUT			
				DUPAGE WATER COMMISSION WATERLINK EXTENSION			
				SHEET NO. 2 of 2			

EXHIBIT C
OSWEGO UNIT SYSTEM STORAGE REQUIREMENTS

Village of Oswego
Water Purchase and Sale Contract

EXHIBIT C
CUSTOMER WATER STORAGE REQUIREMENTS

CUSTOMER	CUSTOMER		ALLOCATION	STORAGE	10%		STORAGE
	EXISTING	2030	AS A	REQUIRED	SHALLOW	PORTION	ABOVE OR
	STORAGE	ALLOCATION	PERCENTAGE	BY	WELL	OF DWC	(BELOW)
	(MG)	(MGD)	OF SYSTEM	CONTRACT	ALLOWANCE	STORAGE	REQUIREMENT
				(MG)	(MG)(1)	(MG)	(MG)
ADDISON	6.75	3.582	3.98%	7.16	0.72	2.49	2.79
ARGONNE	1.60	0.758	0.84%	1.52	0.15	0.53	0.76
BARTLETT	7.50	3.246	3.60%	6.49	0.65	2.25	3.91
BENSENVILLE	3.55	1.907	2.12%	3.81	0.00	1.32	1.06
BLOOMINGDALE	4.80	2.348	2.61%	4.70	0.47	1.63	2.20
CAROL STREAM	6.50	3.667	4.07%	7.33	0.73	2.54	2.44
IAWC ARROWHEAD	0.40	0.145	0.16%	0.29	0.03	0.10	0.24
IAWC COUNTRY CLUB	0.20	0.105	0.12%	0.21	0.02	0.07	0.08
IAWC DU PAGE/LISLE	0.76	0.470	0.52%	0.94	0.09	0.33	0.24
IAWC LOMBARD	0.05	0.050	0.06%	0.10	0.01	0.03	(0.01)
IAWC VALLEY VIEW	0.88	0.520	0.58%	1.04	0.10	0.36	0.30
IAWC LIBERTY RIDGE WEST	0.40	0.300	0.33%	0.60	0.06	0.21	0.07
IAWC LIBERTY RIDGE EAST	0.05	0.030	0.03%	0.06	0.01	0.02	0.02
CLARENDON HILLS	1.25	0.818	0.91%	1.64	0.16	0.57	0.35
DARIEN /DPC-SERWF	4.00	3.269	3.63%	6.54	0.65	2.27	0.38
DOWNERS GROVE	8.00	6.097	6.77%	12.19	1.22	4.23	1.26
DuPAGE COUNTY	2.63	1.483	1.65%	2.97	0.30	1.03	0.99
ELMHURST	15.00	4.083	4.53%	8.17	0.82	2.83	10.48
GLENDALE HEIGHTS	4.70	2.671	2.96%	5.34	0.53	1.85	1.75
GLEN ELLYN	3.25	2.562	2.84%	5.12	0.51	1.78	0.42
HINSDALE	4.50	2.468	2.74%	4.94	0.49	1.71	1.77
ITASCA	3.50	1.486	1.65%	2.97	0.30	1.03	1.86
LISLE	5.50	2.686	2.98%	5.37	0.54	1.86	2.53
LOMBARD	5.60	4.174	4.63%	8.35	0.83	2.90	0.98
NAPERVILLE	43.90	17.454	19.37%	34.91	3.49	12.11	24.59
OAK BROOK	8.00	3.294	3.66%	6.59	0.66	2.29	4.36
OAKBROOK TERRACE	0.50	0.261	0.29%	0.52	0.05	0.18	0.21
OSWEGO (2)	5.30	2.855	3.17%	5.71	0.57	1.98	2.14
ROSELLE	1.75	1.866	2.07%	3.73	0.37	1.29	(0.31)
VILLA PARK	3.80	1.784	1.98%	3.57	0.00	1.24	1.47
WESTMONT	4.50	2.552	2.83%	5.10	0.51	1.77	1.68
WHEATON	7.26	4.846	5.38%	9.69	0.97	3.36	1.90
WILLOWBROOK	4.00	1.031	1.14%	2.06	0.21	0.72	2.86
WINFIELD	1.60	0.916	1.02%	1.83	0.18	0.64	0.59
WOOD DALE	3.35	1.244	1.38%	2.49	0.25	0.86	1.97
WOODRIDGE	6.15	3.058	3.39%	6.12	0.61	2.12	2.77
CUSTOMER TOTAL STORAGE	181.48	90.086	100.00%	180.17	17.28	62.50	81.09
DWC SYSTEM STORAGE	62.50						
TOTAL CUSTOMER AND DWC STORAGE	243.98						

- (1) Customer Shallow Well Allowance and Storage Requirements are audited annually for compliance.
(2) Oswego is currently in design phase for an additional 1.0 MG Ground Level Storage Tank

EXHIBIT D
METER STATION AND ACCESS EASEMENTS

Village of Oswego
Water Purchase and Sale Contract

EXHIBIT D
METER STATION AND ACCESS EASEMENTS
(FORM OF)

DUPAGE WATER COMMISSION

METERING STATION

EASEMENT AGREEMENT

[Meter Station Name]

[PERMANENT REAL ESTATE TAX INDEX NO. XX-XX-XXX-XXX]

Prepared by and Mail to:

Paul D. May, PE
General Manager
DuPage Water Commission
600 East Butterfield Road
Elmhurst, Illinois 60126-4642
630-834-0100

METERING STATION
EASEMENT AGREEMENT
[Meter Station Name]

THIS EASEMENT AGREEMENT, made and entered into this ____ day of _____, 202_, by and between the DUPAGE WATER COMMISSION, a county water commission created and existing under the laws of the State of Illinois (the “Commission”) and the *[MUNICIPALITY]*, a unit of local government created and existing under the laws of the State of Illinois and a customer of the Commission (the “Customer”),

WITNESSETH:

WHEREAS, the Commission and the Customer have entered into a certain Water Purchase and Sale Contract dated as of October 17, 2024 (the “Contract”); and

WHEREAS, the Contract provides that the Commission is to furnish, install, own, operate, maintain, and repair certain equipment and devices, together with certain structures and portions of its water distribution main, including underground feeder pipeline and related equipment, for properly conveying and measuring the quantity of Lake Michigan water delivered by the Commission to the Customer at the connection point provided for under the Contract (collectively referred to as the “Metering Station”); and

WHEREAS, the Contract provides that the Metering Station is to be located at a site selected and provided by the Customer, subject to review and approval by the Commission; and

WHEREAS, the Customer has selected the site legally described in Exhibit 1 attached hereto and by this reference incorporated herein and made a part hereof (the “Metering Station Easement Premises”) for the location of the Metering Station as

generally depicted in Exhibit 2 attached hereto and by this reference incorporated herein and made a part hereof; and

WHEREAS, the Commission has reviewed the Metering Station Easement Premises and approved the same for the location of the Metering Station; and

WHEREAS, the Commission has submitted to the Customer for review the drawings and specifications for the Metering Station; and

WHEREAS, the Commission and the Customer desire to enter into this Easement Agreement in order to provide the Commission with a sufficient property interest in the Metering Station Easement Premises to fulfill the provisions and purpose of the Contract;

WHEREAS, the Commission has duly adopted its Ordinance No. **[O-XX-XX]**, being "An Ordinance Requesting the Intergovernmental Transfer of Easement Rights for the **[Municipality]** Metering Station MS-**[XXX]** Site and Authorizing the Execution of the **[Municipality]** Metering Station Easement Agreement," pursuant to the Local Government Property Transfer Act, 50 ILCS 605/0.01 et seq.; and

WHEREAS, the Customer has duly adopted its Resolution No. **[TBD]**, being "A Resolution Approving the Intergovernmental Transfer of Easement Rights to the DuPage Water Commission," pursuant to the Local Government Property Transfer Act, 50 ILCS 605/0.01 et seq.;

NOW, THEREFORE, in consideration of the foregoing and for other good and valuable consideration, the receipt and sufficiency of which is hereby acknowledged, and in the exercise of their powers and authority under the intergovernmental cooperation provisions of Article VII, Section 10 of the Illinois Constitution of 1970 and the Intergovernmental Cooperation Act, 5 ILCS 220/1 et seq., and other applicable authority, the Commission and the Customer hereby agree as follows:

1. The foregoing recitals are hereby incorporated herein as substantive provisions of this Easement Agreement.

2. The Customer hereby grants, conveys, warrants, and dedicates to the Commission, its successors and assigns, an exclusive perpetual easement to construct, furnish, install, own, operate, maintain, test, inspect, remove, repair, and replace the Metering Station at, in, under, and upon the Metering Station Easement Premises, together with all reasonable rights of ingress and egress along or across any adjoining lands of, or under the jurisdiction and control of, the Customer. The Customer hereby further grants, conveys, warrants, and dedicates to the Commission, its successors and assigns, a non-exclusive perpetual access easement along and across the real property legally described in Exhibit 1 attached hereto and by this reference incorporated herein and made a part hereof (the "Access Easement Premises"). The Customer hereby further grants, conveys, warrants, and dedicates to the Commission, its successors and assigns, a non-exclusive perpetual utility access easement along and across the real property legally described in Exhibit 1 attached hereto and by this reference incorporated herein and made a part hereof (the "Utility Access Easement Premises").

3. The Metering Station shall be not located, constructed, or maintained in any manner not in substantial conformity with Exhibit 2 without the express consent of the Customer, which consent shall not be unreasonably withheld.

4. The Customer hereby further grants to the Commission a temporary construction easement for the installation of the Metering Station upon, along, and across the real property legally described in Exhibit 3 attached hereto and by this reference incorporated herein and made a part hereof (the "Subject Property"). Said temporary construction easement shall be used by the Commission only during periods of actual

installation, replacement or repair activity and for any necessary restoration of the Metering Station Easement Premises.

5. The Commission shall exercise the easement rights hereby granted with due care, and shall not unreasonably interfere with, damage, or harm any Customer property located upon the Subject Property or Customer's adjacent property.

6. After construction of the Metering Station, the Metering Station Easement Premises shall be restored in accordance with the drawings and specifications for the Metering Station. All fences, roads, landscaping, and improvements shall be restored to former condition by the Commission if disturbed or altered in any manner by construction or maintenance activities of the Commission.

7. The Customer hereby reserves the right to use the Metering Station Easement Premises, the Access Easement Premises, the Utility Access Easement Premises, and its adjacent property in any manner that will not prevent or interfere in any way with the exercise by the Commission of the rights granted hereunder; provided, however, that the Customer shall not in any manner disturb, damage, destroy, injure, obstruct, or permit to be obstructed the Metering Station Easement Premises, the Access Easement Premises, or the Utility Access Easement Premises without the express prior written consent of the Commission, nor shall the Customer permanently or temporarily improve, damage, or obstruct the Metering Station Easement Premises, the Access Easement Premises, or the Utility Access Easement Premises in any manner that would impair the exercise by the Commission of the rights hereby granted.

8. To the fullest extent permitted by law, the Customer agrees to indemnify and defend the Commission with respect to any and all claims or damages to persons or property which may arise from the acts of the Customer, or its agents or employees, at

the Metering Station Easement Premises, the Access Easement Premises, the Utility Access Easement Premises, the Subject Property, and its adjacent property in conjunction with its rights pursuant to Paragraph 7 hereof, and, except as otherwise provided in the Contract, the Commission agrees to indemnify and defend the Customer with respect to any and all claims of damages to persons or property which may arise from the of the Commission, or its agents or employees, at the Metering Station Easement Premises, the Access Easement Premises, the Utility Access Easement Premises and the Subject Property in conjunction with its rights pursuant to Paragraphs 2, 4, 5 and 7 hereof. The Customer shall provide to the Commission, and the Commission shall provide to the Customer, a certificate of insurance or proof of self-insurance coverage as evidence of its continuing ability to meet the obligation established in this Paragraph, and both shall maintain such coverage at all times.

9. This Easement Agreement shall constitute and stand in the place of all Customer permits required of the Commission or its contractor to construct, furnish, install, own, operate, maintain, test, inspect, repair, remove, or replace the Metering Station at, in, under, and upon the Metering Station Easement Premises, and the Customer hereby agrees to execute any and all additional documents, approvals, waivers, or consents, if any, that may be reasonably necessary for the Commission to secure any permits required from any county, state, or federal agency for or in connection with constructing, furnishing, installing, owning, operating, maintaining, testing, inspecting, repairing, removing, or replacing the Metering Station.

10. In the event that the Contract is terminated without renewal with respect to the Customer, the Commission shall, within 90 days execute and deliver to the Customer an appropriate document evidencing the termination of this Easement Agreement and

releasing the easement rights hereby granted. The Commission may, within said 90 day period, in its own discretion, and at the Customer's expense, remove the Metering Station from the Metering Station Easement Premises. If the Commission fails to remove the **[Municipality]** Metering Station, as aforesaid, the Customer may take title to the Metering Station.

11. All rights, title, and privileges herein granted, including all benefits and burdens, shall run with the land and shall be binding upon and inure to the benefit of the parties hereto and their respective grantees, successors, assigns, and legal representatives.

12. All representations and warranties contained herein shall survive the execution of this Easement Agreement and the recordation hereof and shall not be merged.

IN WITNESS WHEREOF, the parties hereto have caused this instrument to be executed by their proper representatives duly authorized to execute the same.

DUPAGE WATER COMMISSION

ATTEST:

By: _____
Paul May, PE
General Manager

Danna Mundall
Clerk

[MUNICIPALITY]

By: _____
[NAME]
[Village/City President/Mayor]

ATTEST:

By: _____

Its: _____

EXHIBIT 1

LEGAL DESCRIPTIONS OF THE
METERING STATION EASEMENT PREMISES

PERMANENT METER STATION EASEMENT:

[INSERT LEGAL DESCRIPTION PROVIDED BY CUSTOMER]

PERMANENT ACCESS EASEMENT:

[INSERT LEGAL DESCRIPTION PROVIDED BY CUSTOMER]

EXHIBIT 1

LEGAL DESCRIPTIONS OF THE
METERING STATION EASEMENT PREMISES

PERMANENT UTILITY ACCESS EASEMENT:

[INSERT LEGAL DESCRIPTION PROVIDED BY CUSTOMER]

EXHIBIT 2

PLANS FOR METERING STATION

[PROVIDED BY THE COMMISSION]

EXHIBIT 2-A

MS ELEVATION DRAWINGS

[PROVIDED BY THE COMMISSION]

EXHIBIT 2-B

MS FLOOR PLANS

[PROVIDED BY THE COMMISSION]

EXHIBIT 2-C

MS SECTION DRAWINGS

[PROVIDED BY THE COMMISSION]

EXHIBIT 3

LEGAL DESCRIPTION OF THE TEMPORARY CONSTRUCTION
EASEMENT PREMISES

TEMPORARY CONSTRUCTION EASEMENT:

[INSERT LEGAL DESCRIPTION PROVIDED BY CUSTOMER]

STATE OF ILLINOIS)
) SS
COUNTY OF [])

I, _____, a Notary Public in and for said County, in the State aforesaid, do hereby certify that **[Name]**, personally known to me to be the **[Title]** of the **[Municipality]**, and _____, personally known to me to be the _____ of the Village of Oswego, and personally known to be the same persons whose names are subscribed to the foregoing instrument, appeared before me this day in person and acknowledged that they signed, sealed, and delivered said instrument as their free and voluntary act, and as the free and voluntary act of said Village, for the uses and purposes therein set forth.

Given under my hand and official seal this _____ day of _____, 202_.

Notary Public

My Commission Expires: _____

EXHIBIT E
CAPITAL COST RECOVERY CHARGE

Village of Oswego
Water Purchase and Sale Contract

EXHIBIT E
CAPITAL COST RECOVERY CHARGE

DuPage Water Commission
Calculation of Capital Cost Recovery Charge as of May 1, 2024
For Oswego

Fixed Assets (Audited as of 04-30-2024)	
Land	\$ 11,728,902
Infrastructure	383,618,530
Buildings	110,194,197
Office Equipment	4,763,332
Machinery	27,061,530
Vehicles	1,055,314
CIP	15,415,869
Total	\$553,837,674
Less: Feeder Mains & Meter Stations	94,321,158
	459,516,516
Less: Total Rebates	106,326,287
Total	\$353,190,229

		Total Capital Cost Recovery Charge	
		MGD	
Oswego (CY2022-CY2023 Avg)	2.505	3.128%	\$ 11,047,790
Montgomery (CY2022-CY2023 Avg)	2.267	2.831%	\$ 9,998,815
Yorkville (CY2022-CY2023 Avg)	1.817	2.269%	\$ 8,013,886
DuPage Water Commission (CY2022-CY2023 Avg)	73.483		
Total	80.071		\$ 29,060,491

EXHIBIT F
SCHEDULE OF EVENTS

Village of Oswego
Water Purchase and Sale Contract

EXHIBIT F

OSWEGO ILLUSTRATIVE SCHEDULE OF EVENTS

WEEKS>>	0	13	19	23
I. <u>OSWEGO DUTIES</u> A. Property Interests ----- B. Oswego Connection Facilities ----- C. Water Storage Facilities (Not Applicable)	(CONTRACT SIGNED) Commence acquisition of necessary interests (Section 10G)	Convey all required easements and interests to DWC (Section 10G)	Submit plans and specs for DWC review (Section 10A)	DWC completes review (Section 10A)
II. <u>DWC DUTIES</u> A. Property Interests ----- B. Commission Connection Facilities		Commence Design upon receipt of all required easements and interests (Section 10H)		
III. <u>OTHER EVENTS</u> A. Delivery of Water ----- B. Payment of Costs other than O&M ----- C. Payment of O&M Costs				

EXHIBIT F

OSWEGO ILLUSTRATIVE SCHEDULE OF EVENTS

WEEKS>>	27	28	40
I. <u>OSWEGO DUTIES</u> A. Property Interests <hr/> B. Oswego Connection Facilities <hr/> C. Water Storage Facilities (Not Applicable)	 Complete design of Customer Connection Facilities (Section 10A) 	 Submit for IEPA and local approvals (Section 10B) 	 Projected IEPA and local approvals
II. <u>DWC DUTIES</u> A. Property Interests <hr/> B. Commission Connection Facilities	 	 	
III. <u>OTHER EVENTS</u> A. Delivery of Water <hr/> B. Payment of Costs other than O&M <hr/> C. Payment of O&M Costs	 	 	

EXHIBIT F

OSWEGO ILLUSTRATIVE SCHEDULE OF EVENTS

WEEKS>>	128	158	185
I. <u>OSWEGO DUTIES</u> A. Property Interests ----- B. Oswego Connection Facilities ----- C. Water Storage Facilities (Not Applicable)	----- Commence construction of Customer Connection Facilities (Section 10C) -----	----- Complete construction of Customer Connection Facilities (Section 10C) -----	----- -----
II. <u>DWC DUTIES</u> A. Property Interests ----- B. Commission Connection Facilities	----- -----	----- -----	----- Complete Construction of Commission Connection Facilities (May 1, 2028) -----
III. <u>OTHER EVENTS</u> A. Delivery of Water ----- B. Payment of Costs other than O&M ----- C. Payment of O&M Costs	----- -----	----- -----	Commence Delivery of Lake Water ----- Oswego's First payment due at 1 st billing cycle after earlier of delivery of water or 12 months after Commission Connection Facilities substantially completed. (Section 7M) ----- Oswego's First payment due at 1 st billing cycle after substantial completion of Commission Connection Facilities (Section 7M)

EXHIBIT G

WATERLINK PROJECT ESCROW INTERGOVERNMENTAL AGREEMENT

Village of Oswego
Water Purchase and Sale Contract

**WATERLINK PROJECT
ESCROW INTERGOVERNMENTAL AGREEMENT**

This WaterLink Project Escrow Intergovernmental Agreement (the “WaterLink Project Escrow Agreement” or this “Agreement”) is dated the 17th day of October 2024 between the Village of Montgomery (“Montgomery”), the Village of Oswego (“Oswego”), and the United City of Yorkville (“Yorkville”) (Oswego, Montgomery, and Yorkville are collectively referred to herein as the “WaterLink Communities”) and the DuPage Water Commission (the “Commission”), a county water commission and public corporation under Division 135 of Article 11 of the Illinois Municipal Code, 65 ILCS 5/11-135-1 *et seq.*, and the Water Commission Act of 1985, 70 ILCS 3720/0.01 *et seq.* (the “Acts”).

WITNESSETH:

WHEREAS, the Commission has been organized under the Acts to supply water within its territorial limits; and

WHEREAS, the WaterLink Communities currently own and operate municipal drinking water systems served by wells that extract source water from the Ironton-Galesville aquifer; and

WHEREAS, the WaterLink Communities are within the territorial limits of the Commission; and

WHEREAS, the WaterLink Communities intend to change from the Ironton-Galesville groundwater source to Lake Michigan source water, through water purchase and sale agreements with the Commission, and have applied for and been awarded Lake Michigan Water Allocation Permits from the State of Illinois Department of Natural Resources, Office of Water Resources for each discrete and non-contiguous service area served by each WaterLink Community’s Unit System (“Service Area”); and

WHEREAS, the WaterLink Communities have conducted extensive study and have concluded that the most sustainable alternative water source to serve the WaterLink Communities through the municipal waterworks systems currently serving the WaterLink Communities, as well as any extensions or improvements of those systems, is Lake Michigan water from the Commission; and

WHEREAS, the Commission owns and maintains a waterworks system as a supplier of Lake Michigan water to member customers that contract for such service (“Commission’s Waterworks System”); and

WHEREAS, the parties seek to complete the improvements necessary to connect the Commission’s Waterworks System to the WaterLink Communities’ individual Unit Systems in 2028; and

WHEREAS, the Commission has entered into a Water Supply Contract with the City of Chicago to purchase Lake Michigan water sufficient to meet the water supply needs of the Commission and its customers; and

WHEREAS, the Commission’s Water Supply Contract with the City of Chicago is set to expire in 2041, and the Commission is currently: (1) exploring an alternative solution to obtaining Lake Michigan water; and (2) in discussions and negotiations with the City of Chicago for a new Water Supply Contract; and

WHEREAS, to carry out their duties and responsibilities, and desire to create a method of providing an adequate supply of Lake Michigan water to the Service Area, the Commission and each of the WaterLink Communities, contemporaneously with this Agreement are entering into Water Purchase and Sale Contracts (the “Water Purchase Agreements”) and this Agreement incorporates the defined terms of the Water Purchase Agreements unless otherwise specified herein; and

WHEREAS, to become a member of the Commission and comply with the Water Purchase Agreements, each WaterLink Community must pay its proportional share of the costs for the property owned by the Commission; and

WHEREAS, contemporaneously with this Agreement, the WaterLink Communities and the Commission are each entering into a Capital Cost Recovery Agreements that establish the terms and conditions for financing each WaterLink Community’s proportional share of the costs for the property owned by the Commission; and

WHEREAS, contemporaneously with this Agreement, each WaterLink Community and the Commission are entering into an Intergovernmental Agreement Concerning the Development of Connection Facilities to Implement Water Service (the “Development Agreement”); and

WHEREAS, the WaterLink Communities intend that certain provisions within this Agreement be used only to the extent that one or all of the WaterLink Communities have failed to properly fund this Agreement after notice has been provided in accordance with this Agreement; and

WHEREAS, the Commission will incur in connection with (i) the design, bidding, contracting, managing, and actual construction, installation, removal, relocation, replacement, extension, or improvement of the Connection Facilities, including without limitation equipment required for the operation of the Connection Facilities and all administrative, financing, supervisory, inspection, engineering, surveying, and legal fees, costs, and expenses associated therewith; (ii) the acquisition and divestment of lands, easements, and rights of way over lands and waters necessary for the construction, installation, removal, relocation, replacement, extension, or improvement of the Connection Facilities, and all administrative, title, surveying, and legal fees, costs, and expenses associated therewith; and (iii) the review and processing of plans and agreements for the construction, installation, removal, relocation, replacement, extension, or improvement of the Connection Facilities and in connection with the negotiation, preparation, consideration, and review of this Contract, including without limitation all legal, engineering, consulting, and administrative fees, costs, and expenses associated therewith; except as any of the above are included in Operation and Maintenance Costs (“Connection Facilities Cost”); and

WHEREAS, the Commission and the WaterLink Communities have previously entered into First and Second Escrow Intergovernmental Agreements (the “Prior Escrow Agreements”) for what is defined under those Prior Escrow Agreements as Phase I and Phase 2 Services; and

WHEREAS, prior to the execution of documents requiring the expenditure of Commission Expenses, the Commission requires the WaterLink Communities to establish an additional escrow fund with the Commission as stated herein to provide a funding source for the Commission Expenses beyond those incurred for the Phase 1 and Phase 2 Services; and

WHEREAS, pursuant to the Development Agreement, the WaterLink Communities will be responsible for the Connection Facilities Cost; and

WHEREAS, the WaterLink Communities have previously agreed to each Municipality's percentage share of the Connection Facilities Cost pursuant to an Intergovernmental Cost Share Agreement (the "Cost Share Agreement"). The WaterLink Communities agree that the costs paid into the escrow account under this WaterLink Project Escrow Agreement will mirror the Division of Financial Responsibilities/Allocation of Costs set forth in the Cost Share Agreement. Specifically, Montgomery commits and agrees to pay 24.42%, Yorkville commits and agrees to pay 40.22%, and Oswego commits and agrees to pay 35.36%. The Commission is not a party to the Cost Share Agreement and has no responsibility or liability as to any true-up or adjusted accounting between the WaterLink Communities; and

WHEREAS, pursuant to Article VII, Section 10 of the Illinois Constitution of 1970, and the Intergovernmental Cooperation Act, 5 ILCS 220/1 et seq., the Commission and the WaterLink Communities are authorized to enter into this WaterLink Project Escrow Agreement.

NOW, THEREFORE, in consideration of the foregoing recitals and of the mutual covenants and agreements herein contained, the WaterLink Communities and the Commission hereby agree as follows:

1. The foregoing recitals are by this reference incorporated herein and made a part hereof as if fully set forth herein. Further, to the extent any capitalized terms in this Agreement are set forth as a defined term in the Water Purchase Agreements, the capitalized terms in this Agreement shall have the same meaning in this Agreement as the definition in the Water Purchase Agreements.

2. The Commission will establish a segregated escrow account for the sole purpose of funding the Connection Facilities Cost (the "Waterlink Project Escrow Account"). The WaterLink Communities will each deposit into the Waterlink Project Escrow Account all payments necessary to fund the Connection Facilities Cost. Any remaining funds from the prior Escrow Agreements will remain in the related escrow account, and any funds not expended or necessary for Phase I and Phase II Services, when those phases are complete, may be transferred

to the WaterLink Project Escrow Account, unless otherwise directed by the WaterLink Communities.

3. The Commission will draw from the WaterLink Project Escrow Account to pay for or reimburse any Connection Facilities Cost incurred.

4. The WaterLink Project Escrow Account will be insured and interest-bearing, and the Commission will provide the WaterLink Communities with Quarterly Statements within twenty-one (21) days after the end of each quarter: (1) showing the starting and ending balances for that quarter in the WaterLink Project Escrow Account; and (2) detailing the costs of Connection Facilities Cost incurred for that quarter including any amounts received or paid from the WaterLink Project Escrow Account. The WaterLink Communities will have the right to conduct audits for three years after the termination of this WaterLink Project Escrow Agreement relative to the WaterLink Project Escrow Account.

5. The Commission will keep a record of all pay requests from the WaterLink Project Escrow Account for reimbursement of Connection Facilities Cost incurred (the "Pay Request") and sufficient documentation of the Connection Facilities Cost incurred in support of the Pay Request. The documentation will be retained for review by the WaterLink Communities upon request and included within the Quarterly Statements issued by the Commission.

If at any time during the term of this WaterLink Project Escrow Agreement, the balance in the WaterLink Project Escrow Account is less than Thirty Million Dollars (\$30,000,000.00) (the "Minimum Balance Amount"), the Commission will notify the WaterLink Communities. Within thirty (30) days of the Commission notifying the WaterLink Communities under this Paragraph 5, the WaterLink Communities will each pay the Commission its proportionate share (as set forth in the Cost Share Agreement) of the request to ensure that the Minimum Balance is met. Failure to make such payment when required under this Paragraph 5 shall be considered a default of this Agreement by the WaterLink Communities.

6. The Commission will, after the execution and delivery of this Agreement, make available as a line of credit to the WaterLink Communities an amount not to exceed \$21,000,000

(the “Commitment Amount”) to pay a portion of the Connection Facilities Cost as defined in the Water Purchase Agreements. The actual amounts of money borrowed by each of the WaterLink Communities pursuant to the Commitment Amount will constitute the “Line of Credit.”

7. The WaterLink Communities will repay the principal balance of the Line of Credit, plus accrued and unpaid interest at the Interest Rate set forth in Paragraph 8 of this Agreement from the Interest Commencement Date through the Line of Credit Payment Commencement Date (the “Capitalized Interest”), as those terms are hereinafter defined on the unpaid principal balance, and any Capitalized Interest, of the Line of Credit from and after the Line of Credit Payment Commencement Date, as that term is hereinafter defined, in 240 monthly installments, commencing on the 10th day of every month (the “Monthly Payment Date”) commencing on the Line of Credit Payment Commencement Date as hereafter defined in Paragraph 9 and continuing in successive monthly installments on each Monthly Payment Date in each month thereafter, with the final payment of any unpaid interest and principal, if not sooner paid, on the 240th Monthly Payment Date. Each of the 240 monthly installments of principal on the Line of Credit will be determined as of the last day of the month preceding the Monthly Payment Date in any given year during the term of the Line of Credit (a “Principal Determination Date”) and will be determined by dividing the unpaid principal balance, and any Capitalized Interest, of the Line of Credit as of the applicable Principal Determination Date by the number of monthly installments of principal remaining to be paid during the term of the Line of Credit. The accrued and unpaid interest will be capitalized on a monthly basis until the Line of Credit Payment Commencement Date. There will be no penalty for prepayment.

8. Interest on the unpaid principal balance, and any Capitalized Interest, of the Line of Credit will accrue at a rate (the “Interest Rate”) that is equivalent to the highest yield to maturity interest rate earned by the Commission (based on all investments) as reported monthly on the Commission’s Schedule of Investments for the immediately preceding fiscal year (May 1 – April 30) as determined by the Commission (the “Earned Interest Rate”) plus one percent (1%). Interest will only accrue on money actually borrowed under Paragraph 6 of this Agreement and will begin to accrue when the Commission makes its first draw on the Line of Credit for the WaterLink Communities (the “Interest Commencement Date”). The Interest Rate for each year that the Line

of Credit remains outstanding will be calculated on the basis of a calendar year consisting of 360 days of twelve 30-day months and will be adjusted on May 1st of each year, and will be applied to the outstanding unpaid principal balance, and any Capitalized Interest, as determined on the most recent Principal Determination Date, will be paid commencing on the Monthly Payment Date, and continuing on the Monthly Payment Date each month thereafter until the principal balance of the Line of Credit and all interest thereon has been paid in full.

9. Payments of principal and interest, including Capitalized Interest, will begin no later than the 10th day of the first month after the first delivery of potable, filtered water drawn from Lake Michigan to any of the WaterLink Communities individual Unit Systems as that term is defined in the Water Purchase Agreement (the “Line of Credit Payment Commencement Date”).

10. Payments of the principal and interest will be made in lawful money of the United States of America in federal or other immediately available funds.

11. If at any time, the Commission receives invoices incurred arising out of the Connection Facilities Cost for which there are insufficient funds in the Construction Escrow Agreement, the Commission will pay the actual costs incurred from the Connection Facilities Cost Line of Credit. The Commission payments for the Connection Facilities Cost will be paid out of the Commitment Amount and will be immediately considered part of the Line of Credit. The Commission may make payments from the Line of Credit no more than once per month, on the 10th day of the month, provided that the Commission will give the WaterLink Communities notice (which notice must be received by the WaterLink Communities prior to 10:00 a.m., local time, 7 days prior to the requested borrowing date), specifying the amount to be paid and the payment date. It is anticipated that only a single borrowing will be requested each month. Each borrowing pursuant to this Agreement will be in an aggregate principal amount less than the Available Commitment. For purposes of this Paragraph 11, the Available Commitment at a particular time is an amount equal to the difference between the Commitment Amount and the aggregate principal balance of the Line of Credit then outstanding.

12. Subject to the limitations of Paragraph 12, the WaterLink Communities may, without premium or penalty, upon at least one business day’s irrevocable notice to the

Commission, specifying the date and amount of prepayment, make such prepayment; and the payment amount specified in such notice will be due and payable on the date specified therein. The proceeds of any such prepayment will be applied by the Commission first, to the payment of accrued and unpaid interest, if any, on the Line of Credit, and second, to the payment of the unpaid principal balance of the Line of Credit. The WaterLink Communities will not be entitled to, nor receive any credit for, interest on any such prepayment.

13. The proceeds of the Line of Credit will be devoted to and used with due diligence for the purpose of paying the Connection Facilities Cost identified in Exhibit A; provided, however, that where an unexpended balance remains in any one or more of the various cost components of the Connection Facilities Cost detailed in Exhibit A attached hereto, such balance may be transferred and expended, in whole or in part, to and for any other cost component of the Connection Facilities Cost detailed in Exhibit A attached hereto.

14. The Covenants set forth in Subsections 9A, 9B, 9C, and 9D of the Water Purchase Agreements are incorporated into this Agreement by reference.

15. This WaterLink Project Escrow Agreement will terminate, and any monies not paid or incurred for Connection Facilities Cost, including any interest therein will be returned to the WaterLink Communities, unless mutually agreed to by the WaterLink Communities and the Commission, upon the earlier of:

- a. upon written request by the WaterLink Communities, a written direction that is issued by the General Manager of the Commission that the funds are no longer needed for any Connection Facilities Cost, which direction shall not be unreasonably withheld; or
- b. upon the WaterLink Communities' written notification to the Commission that they are no longer pursuing the purchase of Lake Michigan water from the Commission, and the payment of all the Connection Facilities Cost.

No monies will be returned to the WaterLink Communities until a full accounting has been completed of the expenditures incurred under this WaterLink Project Escrow Agreement.

16. If any WaterLink Community or the Commission defaults in the full and timely performance of any of its obligations hereunder, the non-breaching entity or entities, after first providing written notice to the breaching entity of the event of default and providing the breaching entity ten (10) days to cure the same, will be entitled to invoke its legal rights and remedies as a result thereof, including, but not limited to, its equitable remedy of specific performance. THE FOREGOING NOTWITHSTANDING, NO ENTITY WILL BE LIABLE TO ANOTHER ENTITY OR ANY OF ITS AFFILIATES, AGENTS, EMPLOYEES, OR CONTRACTORS FOR SPECIAL, INDIRECT, EXEMPLARY, INCIDENTAL, PUNITIVE, OR CONSEQUENTIAL DAMAGES.

17. There are no third-party beneficiaries of this WaterLink Project Escrow Agreement and nothing in this WaterLink Project Escrow Agreement, express or implied, is intended to confer on any person other than the Parties hereto (and their respective successors, heirs, and permitted assigns), any rights, remedies, obligations, or liabilities.

18. Any notices under this WaterLink Project Escrow Agreement will be personally delivered, delivered by the deposit thereof in the U. S. Postal Service, postage prepaid, registered, or certified, return receipt requested, or by overnight courier service to the Party at the address listed below or at another address hereafter designated by notice, or by email transmission. Any such notice will be deemed to have been delivered and given upon personal delivery or delivery by a nationally recognized overnight courier service, or deposit with the United States Postal Service or upon receipt of written confirmation that facsimile or email transmission has been successfully completed:

If to the Commission:

Paul D. May, P.E., General Manager
DuPage Water Commission
600 E. Butterfield Road
Elmhurst, IL 60126
Email: may@dpwc.org

With a copy to:

Phillip A. Luetkehans
Luetkehans, Brady, Garner & Armstrong, LLC
105 E. Irving Park Road
Itasca, IL 60143
Email: pal@lbgalaw.com

If to the WaterLink Communities:

Village Administrator
Village of Oswego
100 Parkers Mill
Oswego, IL 60543
Email: info@oswegoil.org

With a copy to:

David J. Silverman
Village Attorney
Mahoney, Silverman, & Cross, LLC
126 South Main Street
Oswego, Illinois 60543

Village Administrator
Village of Montgomery
200 N River Street
Montgomery, IL 60538
Email: zoephel@montgomeryil.org

With a copy to:

Laura M. Julien
Village Attorney
Mickey Wilson, Weiler, Renzi, Lenert, & Julien, PC
140 Municipal Drive
Sugar Grove, IL 60554

City Administrator
United City of Yorkville
800 Game Farm Road
Yorkville, IL 60560
Email: bolson@yorkville.il.us

With a copy to:

Kathleen Field Orr & Associates
Kathleen Field Orr
2024 Hickory Road, Suite 205
Homewood, IL 60430

With a copy to:

Irene Schild Caminer
Caminer Law, LLC
2612 W. Sunnyside Ave.
Chicago, IL 60625
Email: Irene@caminerlaw.com

19. Each WaterLink Community will hold the Commission harmless and defend the Commission from any claims or litigation that arise out of the engineering, construction, property acquisition, and easement acquisitions for the Connection Facilities being constructed for the WaterLink Communities due to one of all of the WaterLink Communities' failure to comply with the payment obligations arising under this WaterLink Project Escrow Agreement.

20. Miscellaneous.

- a. This WaterLink Project Escrow Agreement shall be deemed to supplement the Water Purchase Agreements in connection with the supply of Lake Michigan water to the Waterlink Communities' individual Unit Systems. If there is any other conflict or inconsistency between the terms of this Agreement and the terms of the Water Purchase Agreements, then the terms of this WaterLink Project Escrow Agreement shall control. The WaterLink Communities shall at all times comply with all terms and conditions of the Water Purchase Agreements except as otherwise provided in this Agreement.

- b. Except as provided herein, the WaterLink Communities and the Commission will not assign this WaterLink Project Escrow Agreement or any right or privilege any WaterLink Communities and the Commission may have under this WaterLink Project Escrow Agreement without the prior written consent of all Parties hereto, not to be unreasonably withheld conditioned or delayed.
- c. This WaterLink Project Escrow Agreement shall be governed by and construed exclusively under the applicable laws, but not the conflict of laws rules, of the State of Illinois. Venue for any litigation arising out of this Agreement shall only be proper in the Eighteenth Judicial Circuit Court, DuPage County, Illinois.
- d. The person(s) executing this WaterLink Project Escrow Agreement on behalf of the Parties hereto warrant that: (i) each WaterLink Community and the Commission are duly organized and existing; (ii) the individual signing is duly authorized to execute and deliver this WaterLink Project Escrow Agreement on behalf of said WaterLink Community or the Commission; (iii) by so executing this WaterLink Project Escrow Agreement, such WaterLink Community and the Commission are formally bound to the provisions and conditions contained in this WaterLink Project Escrow Agreement; and (iv) the entering into this WaterLink Project Escrow Agreement by a WaterLink Community and the Commission does not violate any provision of any other agreement to which said WaterLink Community and the Commission is bound.
- e. Each WaterLink Community and the Commission acknowledge that it may be necessary to execute documents other than those specifically referred to herein in order to complete the objectives and requirements that are set forth in this WaterLink Project Escrow Agreement. Each WaterLink Community and the Commission hereby agree to cooperate with each other by executing such other documents or taking such other actions as may be reasonably necessary to complete the objectives and requirements set forth herein in accordance with the intent of each WaterLink Community and the Commission as evidenced by this WaterLink Project Escrow Agreement.

- f. This WaterLink Project Escrow Agreement is the entire agreement between the WaterLink Communities and the Commission regarding its subject matter and may not be changed or amended except pursuant to a written instrument signed by each WaterLink Community and the Commission.
- g. This WaterLink Project Escrow Agreement may be executed in any number of identical counterparts, each of which will be considered an original, but which together will constitute one and the same agreement.

IN WITNESS WHEREOF, each WaterLink Community and the Commission hereto have caused their respective corporate names to be subscribed hereto and their respective corporate seals to be affixed hereto and attested by their duly authorized officers.

ATTEST:

DuPage Water Commission

BY: _____

ATTEST:

Village of Montgomery

BY: _____

ATTEST:

Village of Oswego

BY: _____

ATTEST:

United City of Yorkville

BY: _____

EXHIBIT A

CONNECTION FACILITIES COST

WATERLINK PROJECT ESCROW INTERGOVERNMENTAL AGREEMENT

EXHIBIT A

CONNECTION FACILITIES COST ESTIMATE (1)

CONSTRUCTION (including 25% contingency)	\$210,389,827
PROPERTY INTERESTS/LAND ACQUISITION	\$17,477,530
LEGAL & ADMINISTRATIVE	\$1,000,000
ENGINEERING	\$28,000,000
	<hr/>
	\$256,867,357
COST ESCALATION OVER PROJECT DURATION	\$26,699,000
	<hr/>
ESTIMATED PROJECT COST (2)	\$283,566,357

- (1) COST ESTIMATE IS BASED UPON FORECASTED PROJECT COSTS AS OF THE DATE IDENTIFIED BELOW AND IS PROVIDED FOR REFERENCE ONLY. ACTUAL PROJECT COSTS WILL BE BASED UPON AWARDED PROJECT CONTRACT(S) AND ACTUAL REALIZED UNIT PRICE AND LUMP SUM COSTS, INCLUDING PROPERTY ACQUISITION, ENGINEERING, LEGAL AND COMMISSIONING COSTS, ALL OF WHICH HAVE BEEN ESTIMATED HEREIN BUT WILL NOT BE FINALLY DETERMINED UNTIL THE COMPLETION OF THE PROJECT AND FINAL COMMISSIONING.
- (2) BASED UPON ESTIMATES INCLUDED IN THE PROJECT DEVELOPMENT REPORT DATED FEBRUARY 1, 2024



Resolution #: R-60-24, R-61-24, R-62-24, R-63-24, R-64-24, and R-65-24

Account: N/A

Approvals: *Author / Manager / Finance / Admin*

REQUEST FOR BOARD ACTION

Date: 10/9/2024

Description: **Recommendation to Approve Water Purchase and Sales Agreement(s) and Capital Cost Recovery Charge Agreement(s) for the WaterLink communities of Oswego, Yorkville, and Montgomery**

Agenda Section: Administration Committee

Originating Department: Administration

I am pleased to present the WaterLink Customer Agreements for DWC Board consideration. The WaterLink communities have been working toward a new water source for over 10 years after becoming aware of impending water scarcity in the aquifer which provides their current supply. After extended study, the WaterLink partners (Oswego, Montgomery, and Yorkville), identified Lake Michigan source water delivered by the DuPage Water Commission as the preferred future source. This project will be one of the largest water projects in the Midwest, and will extend the DWC service area into Kendall counties with DWC water transmission infrastructure extending west of the Fox River upon completion.

The WaterLink communities have received IDNR allocations and have worked with DWC to fund Phase I and Phase II engineering over the last two years. During this period of time, the WaterLink communities have also been preparing financing instruments to fund the construction of the new infrastructure necessary to be constructed by DWC to convey water to the WaterLink communities. All project costs, including legal, engineering, property acquisition, construction, and commissioning will be funded by the WaterLink communities through a WaterLink Connection Facilities Agreement (R-66-24) and companion Project Escrow agreement (R-67-24), also included on this agenda.

The contract documents presented for approval have been crafted to provide continuity with previously approved Subsequent Customer Agreements to the greatest extent possible. DWC Legal Counsel and staff have worked closely with the WaterLink communities, their staff, and their legal counsel over many months to advance these documents for consideration. I wish to acknowledge and thank them for the significant effort that was provided to complete this task.

A summary of the primary elements of the Agreements is provided following:

Water Purchase and Sales Agreements (R-60-24, R-62-24, R-64-24):

The Water Purchase and Sale Agreement(s) have been constructed to provide a term that matches that of the other Contract Customers, ending February 24, 2064; and include language, terms, and conditions consistent with DWC Contract Customers. The project is scheduled for construction to commence in 2025 and to be commissioned in 2028. WaterLink communities will begin to access the new water source at that time, or as soon as permitted based upon achieving compliance with the IDNR water loss regulations.

Capital Cost Recovery Charge Agreements (R-61-24, R-63-24, R-65-24):

All new (subsequent) DWC customers are required to provide a Capital Cost Recovery Charge (aka “buy-in fee”) to ensure parity with the original Charter Customers which paid for the original DWC system upon formation. The Capital Cost Recovery Charged is determined by computing each customer’s pro-rata share by utilizing their IDNR allocation to calculate their demand as a percentage of the whole, and multiplying that percentage by the value of all DWC fixed assets as of the most recently audited fiscal year (FYE 2024). Based upon these computations, the Capital Cost Recovery Charges to be collected are as follows:

Oswego:	\$11,047,790
Montgomery:	\$ 9,998,815
Yorkville:	\$ 8,013,886

Companion Agreements:

In addition to the 1) Water Purchase and Sale Contract(s) and 2) Capital Cost Recovery Charge Agreement(s) for each of three WaterLink Communities, there are also two additional agreements for which there are four parties/signatories: the Village of Oswego, the Village of Montgomery, the United City of Yorkville, and the DuPage Water Commission. These items are included on the DWC October 17, 2024 DWC Agenda and are listed below:

- Resolution R-66-24: WaterLink Connection Facilities Intergovernmental Agreement
- Resolution R-67-24: WaterLink Project Escrow Agreement

Recommended Motion:

It is recommended that the DWC Board approve the Water Purchase and Sales Agreement(s) and the Capital Cost Recovery Charge Agreement(s) for the WaterLink communities of Oswego, Montgomery, and Yorkville.

DUPAGE WATER COMMISSION

RESOLUTION NO. R-61-24

A RESOLUTION APPROVING AN INTERGOVERNMENTAL AGREEMENT WITH
THE VILLAGE OF OSWEGO CONCERNING CAPITAL COST RECOVERY CHARGE

WHEREAS, the Commission was formed and exists pursuant to the Water Commission Act of 1985, 70 ILCS 3720/0.01 et seq., and Division 135 of Article 11 of the Illinois Municipal Code, 65 ILCS 5/11-135-1 et seq., for the purpose of securing an adequate source and supply of water for its customers; and

WHEREAS, the Village of Montgomery (“Montgomery”), the Village of Oswego (“Oswego”) and the United City of Yorkville (“Yorkville”) (Oswego, Montgomery and Yorkville are collectively referred to herein as the “Municipalities”) desire to supply Lake Michigan water to their residents by connecting to the Commission’s waterworks system (the “Project”); and

WHEREAS, the Commission and Oswego have negotiated an Intergovernmental Agreement Concerning Capital Cost Recovery Charge and a Water Purchase and Sale Contract for the Project; and

WHEREAS, concurrently with the enactment of this Resolution, the Commission and the Municipalities are entering into an Intergovernmental Agreement Concerning Development of Connection Facilities to Implement Water Service for the Project;

WHEREAS, concurrently with the enactment of this Resolution, the Commission and the Municipalities are entering into a WaterLink Project Escrow Intergovernmental Agreement with the Municipalities for the Project; and

WHEREAS, the Commission deems it to be in the best interests of the Commission and the public to complete the Project and enter into the Intergovernmental Agreement with the Village of Oswego Concerning Capital Cost Recovery Charge.

NOW, THEREFORE, BE IT RESOLVED by the Board of Commissioners of the DuPage Water Commission as follows:

SECTION ONE: The Board of Commissioners of the DuPage Water Commission hereby approves the Intergovernmental Agreement with the Village of Oswego Concerning Capital Cost Recovery Charge attached hereto as Exhibit 1 and authorizes the Chairman to execute the agreement on behalf of the DuPage Water Commission and to take whatever steps necessary to effectuate the terms of said agreement.

SECTION TWO: This Resolution shall be in full force and effect after passage and approval as required by law.

	Aye	Nay	Absent	Abstain
Bouckaert, D.				
Cuzzone, N.				
Fennell, J.				
VACANT	_____			
Novotny, D.				
Pruyn, J.				
Romano, K.				
Rush, K.				
Russo, D.				
Saverino, F.				
Suess, P.				
Van Vooren, D.				
Zay, J.				

ADOPTED THIS _____ DAY OF _____, 2024.

James F. Zay, Chairman

ATTEST:

Danna Mundall, Clerk

EXHIBIT 1

RESOLUTION NO. 24 - R - 79

RESOLUTION AUTHORIZING THE EXECUTION OF AN INTERGOVERNMENTAL AGREEMENT CONCERNING CAPITAL COST RECOVERY CHARGE BETWEEN THE VILLAGE OF OSWEGO AND THE DUPAGE WATER COMMISSION

WHEREAS, the Village of Oswego (“Village”) has a population of more than 25,000 and is therefore a “Home Rule Unit” under the 1970 Illinois Constitution; and

WHEREAS, the Illinois Constitution of 1970 provides that a Home Rule Unit may exercise any power and perform any function pertaining to its government and affairs, including but not limited to the power to regulate for the protection of the public health, safety, morals and welfare; to license, to tax; and to incur debt; and

WHEREAS, on December 14, 2021, the Village of Oswego Board of Trustees approved Resolution 21-R-101, Designating Lake Michigan as the Preferred Water Source and the DuPage Water Commission as the Preferred Water Supplier for the Village of Oswego; and

WHEREAS, on May 6, 2022, the State of Illinois enacted Public Act 102-0736, allowing for representation of non-DuPage County communities on the DuPage Water Commission Board of Commissioners; and

WHEREAS, on June 28, 2022, the citizens of Oswego approved a referendum to implement a real estate transfer tax dedicated to funding water system improvements, including the connection to Lake Michigan water; and

WHEREAS, on May 2, 2023, the Village of Oswego Board of Trustees approved Resolution 23-R-30, Authorizing the Execution of an Escrow Intergovernmental Agreement with the Village of Montgomery, the United City of Yorkville, and the DuPage Water Commission to fund Phase I engineering for the connection of the communities to the DuPage Water Commission Lake Michigan water system; and

WHEREAS, on August 10, 2023, the Village of Oswego received a Lake Michigan Water Allocation Permit from the Illinois Department of Natural Resources to access Lake Michigan water for the community water supply; and

WHEREAS, on November 7, 2023, the Village of Oswego Board of Trustees approved Ordinance 23-72, establishing new water and sewer rates to fund the connection to Lake Michigan water; and

WHEREAS, on March 18, 2024, the Village of Oswego Board of Trustees approved Resolution 24-R-24, Authorizing the Execution of a Second Escrow Intergovernmental Agreement with the Village of Montgomery, the United City of Yorkville, and the DuPage Water Commission to fund Phase II engineering for the connection of the communities to the DuPage Water Commission Lake Michigan water system; and

WHEREAS, on April 16, 2024, the Village of Oswego Board of Trustees approved Resolution 24-R-33, Authorizing the Execution of an Agreement with Cornell Engineering Group, for Optimal Corrosion Control Treatment Study to ensure that the switch from well water to lake water is done safely; and

WHEREAS, on May 7, 2024, the Village of Oswego Board of Trustees approved Resolution 24-R-44, Authorizing the Execution of an Intergovernmental Agreement Providing for the Sharing of Costs and Funding for the Construction of Facilities to Transport Lake Michigan Water to the Village of Oswego, the United City of Yorkville, and the Village of Montgomery; and

WHEREAS, The Parties deem it to be in their best interests to approve this Intergovernmental Agreement Concerning Capital Cost Recovery Charge.

NOW, THEREFORE, BE IT RESOLVED BY THE PRESIDENT AND BOARD OF TRUSTEES OF THE VILLAGE OF OSWEGO, KENDALL AND WILL COUNTIES, ILLINOIS, as follows:

SECTION 1. INCORPORATION OF RECITALS

That the recitals set forth above are incorporated here by reference.

SECTION 2. APPROVAL OF AGREEMENT

The Village President and Village Board of Trustees hereby approve the Intergovernmental Agreement Concerning Capital Cost Recovery Charge between the Village of Oswego and the DuPage Water Commission, and the Village President and Village Clerk are authorized and directed to execute on behalf of the Village of Oswego the Intergovernmental Agreement Concerning Capital Cost Recovery Charge substantially in the form attached as “Exhibit A.”

SECTION 3. REPEALER

All Resolutions or parts of Resolutions in conflict with any of the provisions of this Resolution shall be, and the same hereby repealed to the extent of the conflict.

SECTION 4. SEVERABILITY

This Resolution and every provision thereof shall be considered severable. If any section, paragraph, clause or provision of this Resolution is declared by a court of law to be invalid or unconstitutional, the invalidity or unconstitutionality thereof shall not affect the validity of any other provisions of this Resolution.

SECTION 5. EFFECTIVE DATE

This Resolution shall be in full force and effect from and after its passage and approval in the manner provided by law.

PASSED by the Board of Trustees of the Village of Oswego, Kendall and Will Counties, Illinois this 1st day of October 2024.

TOM GUIST	<u>AYE</u>	JENNIFER JONES SINNOTT	<u>ABSENT</u>
KIT KUHRT	<u>AYE</u>	KARIN MCCARTHY-LANGE	<u>AYE</u>
KAREN NOVY	<u>AYE</u>	ANDREW TORRES	<u>AYE</u>

APPROVED by me, Ryan Kauffman, as President of the Village of Oswego, Kendall and Will Counties, Illinois this 1st day of October 2024.



 RYAN KAUFFMAN, VILLAGE PRESIDENT



 TINA TOUCHETTE, VILLAGE CLERK

STATE OF ILLINOIS)
)
COUNTY OF KENDALL) SS

CLERK'S CERTIFICATE
(RESOLUTION)

I, Tina Touchette, the duly qualified and acting Village Clerk of the Village of Oswego, Kendall and Will Counties, Illinois, do hereby certify that I am the keeper of its books and records and that the attached hereto is a true and correct copy of a Resolution entitled:

RESOLUTION AUTHORIZING THE EXECUTION OF AN INTERGOVERNMENTAL AGREEMENT CONCERNING CAPITAL COST RECOVERY CHARGE BETWEEN THE VILLAGE OF OSWEGO AND THE DUPAGE WATER COMMISSION

which Resolution was duly adopted by said Board of Trustees at a meeting held on the 1st day of October 2024, and thereafter approved by the Village President on the 1st day of October 2024.

I do further certify, in my official capacity, that a quorum of said Board of Trustees was present at said meeting and that the Board complied with all requirements of the Illinois Open Meetings Act.

IN WITNESS WHEREOF, I have hereunto set my hand this 2nd day of October 2024.

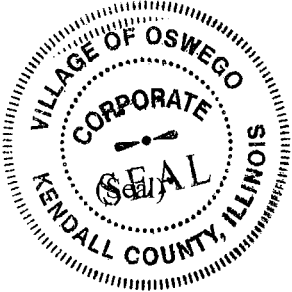

Tina Touchette, Village Clerk
Village of Oswego

EXHIBIT A

**INTERGOVERNMENTAL AGREEMENT WITH THE VILLAGE OF OSWEGO
CONCERNING CAPITAL COST RECOVERY CHARGE**

This Intergovernmental Agreement, (the “Agreement”) is dated the 17th day of October 2024 (the “Effective Date”), by and between the Village of Oswego (“Village”) and the DuPage Water Commission (the “Commission”), a county water commission and public corporation under Division 135 of Article 11 of the Illinois Municipal Code, 65 ILCS 5/11-135-1 *et seq.*, and the Water Commission Act of 1985, 70 ILCS 3720/0.01 *et seq.* (the “Acts”).

WITNESSETH:

WHEREAS, the Commission has been organized under the Acts to supply water within its territorial limits; and

WHEREAS, the Village currently owns and operates a municipal drinking water system (“Oswego Unit System”) served by wells that extract source water from the Ironton-Galesville aquifer; and

WHEREAS, the Village is within the territorial limits of the Commission; and

WHEREAS, the Village intends to change from the Ironton-Galesville groundwater source to Lake Michigan source water, through a Water Purchase and Sale Contract with the DuPage Water Commission, and has applied for and received a Lake Michigan Water Allocation Permit (“Permit”) from the State of Illinois Department of Natural Resources, Office of Water Resources; and

WHEREAS, the Village has conducted extensive study and has concluded that the most sustainable alternative water source to serve the Village through the municipal waterworks system currently serving the Village, as well as any extensions or improvements of that system, is Lake Michigan water from the Commission; and

WHEREAS, the Commission owns and maintains a waterworks system as a supplier of

Lake Michigan water to member customers that contract for such service (“Commission’s Waterworks System”); and

WHEREAS, the Village is seeking to obtain water for its residents beginning in 2028 from the Commission in the incorporated areas within the Village (the “Service Area”); and

WHEREAS, the Village seeks to connect to Lake Michigan through the Commission; and

WHEREAS, the Commission has entered into a water supply contract with the City of Chicago to purchase Lake Michigan water sufficient to meet the water supply needs of the Commission and its customers; and

WHEREAS, the Commission’s water supply contract with the City of Chicago is set to expire in 2041 and the Commission is currently: (1) exploring an alternative solution to obtaining Lake Michigan water; and (2) in discussions and negotiations with the City of Chicago for a new water supply agreement; and

WHEREAS, to carry out their duties and responsibilities, and desire to create a method of providing an adequate supply of Lake Michigan water to the Oswego Unit System, the Commission, and the Village, concurrent with this Agreement, are entering into the Water Purchase and Sale Contract dated October 17, 2024, WaterLink Project Escrow Intergovernmental Agreement, and an Intergovernmental Agreement Concerning Development of Connection Facilities to Implement Water Service; and

WHEREAS, to become a member of the Commission and comply with the Water Purchase and Sale Contract, the Village must pay its proportional share of the costs for the property owned by the Commission (the “Capital Cost Recovery Charge”); and

WHEREAS, the Commission previously enacted Resolution R-79-04 allowing the Commission the ability to finance the Capital Cost Recovery Charge for potential Subsequent

Customers (customers other than its original customers) requesting such accommodation on a case-by case basis; and

WHEREAS, the matters set forth in this Agreement will serve the public interest, and the Commission and the Village deem it to be in each of their best interests for the Commission to provide financing to the Village for the money necessary to pay the Capital Cost Recovery Charge and enter into this Agreement; and

WHEREAS, pursuant to Section 10 of Article VII of the Illinois Constitution of 1970, the provisions of the Intergovernmental Cooperation Act, 5 ILCS 220/1 *et seq.*, and other applicable authority, the Commission and the Village are authorized to enter into this Agreement.

NOW, THEREFORE, in consideration of the foregoing and the mutual covenants and agreements hereinafter set forth, the Commission and the Village hereby agree as follows:

SECTION 1. PREAMBLES

The foregoing recitals are by this reference incorporated herein and made a part hereof as if fully set forth herein.

SECTION 2. COMMISSION FINANCING

A. Capital Cost Recovery Financing. The Commission will, after the execution and delivery of this Agreement, provide financing to the Village in the amount of \$11,047,790.00 (the “Capital Cost Recovery Amount”).

B. Payment Terms.

1. The Village will pay the Commission the principal balance of the Capital Cost Recovery Amount in 360 monthly installments, commencing at the time the first payment is due under Subsection 7M in the Water Purchase and Sale Contract (the “Monthly Payment Date”), and continuing in successive monthly installments on each Monthly Payment Date, with the

final payment of any principal, if not sooner paid, on the 360th Monthly Payment Date. Each of the 360 monthly installments of principal for the Capital Cost Recovery Amount will be in the amount of \$30,688.31, except that the final payment will be in the amount of \$30,686.71.

2. Interest on the unpaid principal balance of the Capital Cost Recovery Amount, will accrue at the rate of zero percent (0%) per annum.

C. Tender of Capital Cost Recovery Amount Payments. Payments of the principal of and interest will be made in lawful money of the United States of America in federal or other immediately available funds.

D. Asset-in-Kind Contribution. To the extent the Village agrees to pay for a portion of the increase in size of the primary 48” western pipeline (commencing at Book Road and 75th Street and extending west of the Fox River to a termination point at Orchard Road, also known as “TW 6/25” in the DWC naming convention), from the baseline pipe size to 54”, the value of that contribution by the Village will be mutually agreed upon and set forth in a separate agreement between the Commission and the Village before the closing of the WIFIA Loan.

E. Covenants. The covenants set forth in Subsections 9A, 9B, 9C, and 9D of the Water Purchase and Sale Contract are incorporated into this Agreement by reference.

SECTION 3. DEFAULTS AND REMEDIES

A. Commission Defaults. The occurrence of the following will constitute a default by the Commission under this Agreement: The failure by the Commission to observe and/or perform any covenant, condition, and/or agreement on its part to be observed and/or performed under this Agreement, and the continuation of said failure for thirty (30) days after the Commission’s receipt of written notice thereof from the Village. However, if said failure cannot be remedied by the Commission within said thirty (30) day period and the Commission has diligently pursued the

resolution of the failure during said thirty (30) days, the period will be extended by such additional time as may be reasonably required by the Commission to cure or correct said failure. In no event will the period be extended by more than ninety (90) days. In the event of a default by the Commission under this Agreement, the Village will have the same remedies as are provided for, and only the remedies provided for, in the Water Purchase and Sale Contractt for a default by the Commission.

B. Village Defaults. The occurrence of the following will constitute a default by the Village under this Agreement:

1. The failure by the Village to observe and/or perform any covenant, condition, and/or agreement on its part to be observed and/or performed under this Agreement, and the continuation of said failure for thirty (30) days after the Village's receipt of written notice thereof from the Commission. However, if said failure cannot be remedied by the Village within said thirty (30) day period and the Village has diligently pursued the resolution of the failure during said thirty (30) days, the period will be extended by such additional time as may be reasonably required by the Village to cure or correct said failure. In no event will the period be extended by more than ninety (90) days. In the event of a default by the Village under this Agreement, the Commission will have the same remedies as are provided for, and only the remedies provided for, in the Water Purchase and Sale Contract for a default by the Village;
2. A default under the October 17, 2024 Intergovernmental Agreement Concerning Development of Connection Facilities to Implement Water Service ; or

3. A default under the October 17, 2024 WaterLink Project Escrow Intergovernmental Agreement.

In the event of a default by the Village, the Commission will: (i) be paid its reasonable attorneys' fees and costs incurred in connection with that default, in addition to any attorneys' fees and costs incurred in enforcing the terms of this Agreement; (2) be entitled to the right to enforce a lien against all income derived from the Oswego Unit System, other than that income necessary to pay any loans to the State of Illinois or its agencies for the construction of the Oswego Unit System, until the Village's Capital Cost Recovery Amount and any amounts due from the Village under the WaterLink Project Escrow Intergovernmental Agreement are paid back in full; and (3) will have the same remedies as are provided for in the Water Purchase and Sale Contract for a default by the Village.

C. Force Majeure. In case by reason of a force majeure event, either party to this Agreement will be rendered unable wholly or in part to carry out its obligation under this Agreement, then if such party will give notice and full particulars of such force majeure event in writing to the other party within a reasonable time after occurrence of the event or cause relied on, the obligation of the party giving such notice, so far as it is affected by such force majeure event, will be suspended during the continuance of the inability then claimed, but for no longer period, and any such party will endeavor to remove or overcome such inability with all reasonable dispatch. The term "force majeure event" as employed in this Agreement will mean acts of God, strikes, lockouts, or other industrial disturbances, acts of public enemy, orders of any kind of the Government of the United States, of the State of Illinois, or of any civil or military authority, insurrections, riots, epidemics, pandemics, landslides, lightning, earthquakes, fires, hurricanes, storms, floods, washouts, droughts, arrests, restraints of government and people, civil disturbances, explosions, breakage or accidents to machinery, pipelines, canals, or tunnels, partial or entire

failure of water supply, and inability on the part of the Commission or of the Village to deliver Lake Michigan water, or of the Village to receive Lake Michigan water, on account of any other causes not reasonably within the control of the party claiming such inability. The settlement of strikes and lockouts will be entirely within the discretion of the party having the difficulty, and the above requirement that any “force majeure event” will be remedied with all reasonable dispatch will not require the settlement of strikes and lockouts by acceding to the demands of the opposing party or parties when such settlement is unfavorable to it in the judgment of the party having the difficulty.

SECTION 4. LEGAL RELATIONSHIPS AND REQUIREMENTS

A. Supplemental Agreement. This Agreement will be deemed to supplement the Water Purchase and Sale Contract in connection with the supply of Lake Michigan water to the Oswego Unit System. If there is any other conflict or inconsistency between the terms of this Agreement and the terms of the Water Purchase and Sale Contract, then the terms of this Agreement will control. The Village will at all times comply with all terms and conditions of the Water Purchase and Sale Contract, except as otherwise provided in this Agreement.

B. Term of Agreement. This Agreement will continue in full force and effect from the Effective Date until the Capital Cost Recovery Amount is paid in full by the Village.

C. Cooperation and Further Agreements. The Commission and the Village agree to cooperate in good faith throughout the term of this Agreement to implement the letter and spirit of the provisions set forth in this Agreement.

D. Assignment. This Agreement may not be assigned by any party, in whole or in part, without the prior written consent of the other party.

E. Notices. Any notices under this Agreement will be personally delivered, delivered by the deposit thereof in the U. S. Postal Service, postage prepaid, registered, or certified, return

receipt requested, or by overnight courier service to the Party at the address listed below or at another address hereafter designated by notice, or by email transmission. Any such notice will be deemed to have been delivered and given upon personal delivery or delivery by a nationally recognized overnight courier service, or deposit with the United States Postal Service or upon receipt of written confirmation that facsimile or email transmission has been successfully completed:

If to the Commission:

Paul D. May, P.E., General Manager
DuPage Water Commission
600 E. Butterfield Road
Elmhurst, IL 60126
Email: may@dpwc.org

With a copy to:

Phillip A. Luetkehans
Luetkehans, Brady, Garner & Armstrong
2700 International Drive, Suite 305
West Chicago, IL 60185
Email: pal@lbgalaw.com

If to the Village:

Village Administrator
Village of Oswego
100 Parkers Mill
Oswego, IL 60543
Email: info@oswegoil.org

With a copy to:

David J. Silverman
Village Attorney
Mahoney, Silverman, & Cross, LLC
126 South Main Street
Oswego, Illinois 60543

With a copy to:

Irene Schild Caminer
Caminer Law, LLC
2612 W. Sunnyside Ave.
Chicago, IL 60625
Email: Irene@caminerlaw.com

By notice complying with the requirements of this Section 4.E, the Commission and the Village each will have the right to change the address or addressee or both for all future notices to it, but no notice of a change of address will be effective until actually received.

F. No Oral Agreements. No oral agreements exist by or between the Commission and the Village with respect to this Agreement, nor was the making and execution of this Agreement induced by any representation, statement, warranty, agreement, or action other than those expressed or explicitly referenced in this Agreement.

G. No Waiver. No course of dealing or failure of the Commission or the Village to enforce strictly any term, right, or condition of this Agreement will be construed as a waiver of such term, right, or condition. No express waiver of any term, right, or condition of this Agreement will operate as a waiver of any other term, right, or condition.

H. No Third-Party Beneficiaries. This Agreement is entered into solely for the benefit of the contracting parties, and nothing in this Agreement is intended, either expressly or impliedly, to provide any right or benefit of any kind whatsoever to any person or entity who is not a party to this Agreement, or to acknowledge, establish, or impose any legal duty to any third party.

I. Governing Law and Venue. This Agreement will be governed by and construed exclusively under the applicable laws, but not the conflict of laws rules, of the State of Illinois. Venue for any litigation arising out of this Agreement will only be proper in the Eighteenth Judicial Circuit Court, DuPage County, Illinois.

J. Counterparts. This Agreement may be executed in several counterparts, each of which will be deemed to be an original, and all of which will constitute but one and the same instrument. Any such counterpart may be signed by one or more of the parties hereto so long as each of the parties hereto has signed one or more of such counterparts.

K. Authority. The person(s) executing this Agreement on behalf of the Parties hereto warrant that: (i) such the Village and the Commission are duly organized and existing; (ii) the individual signing is duly authorized to execute and deliver this Agreement on behalf of said Village or the Commission; (iii) by so executing this Agreement, such Village and the Commission are formally bound to the provisions and conditions contained in this Agreement; and (iv) the entering into this Agreement by the Village and the Commission does not violate any provision of any other agreement to which said Village and the Commission is bound.

L. Mutual Cooperation. The Village and the Commission acknowledge that it may be necessary to execute documents other than those specifically referred to herein in order to complete the objectives and requirements that are set forth in this Agreement. The Village and the Commission hereby agree to cooperate with each other by executing such other documents or taking such other actions as may be reasonably necessary to complete the objectives and requirements set forth herein in accordance with the intent of the Village and the Commission as evidenced by this Agreement.

M. Amendment. This Agreement is the entire agreement between the Village and the Commission regarding its subject matter and may not be changed or amended except pursuant to a written instrument signed by the Village and the Commission.

IN WITNESS WHEREOF, the Village and the Commission hereto have caused their respective corporate names to be subscribed hereto and their respective corporate seals to be affixed hereto and attested by their duly authorized officers.

ATTEST:

DuPAGE WATER COMMISSION

By: _____

By: _____

Its: _____

Its: _____

ATTEST:

VILLAGE OF OSWEGO

By:  _____

By:  _____

Its: Village Clerk

Its: Village President

**INTERGOVERNMENTAL AGREEMENT WITH THE VILLAGE OF OSWEGO
CONCERNING CAPITAL COST RECOVERY CHARGE**

This Intergovernmental Agreement, (the “Agreement”) is dated the 17th day of October 2024 (the “Effective Date”), by and between the Village of Oswego (“Village”) and the DuPage Water Commission (the “Commission”), a county water commission and public corporation under Division 135 of Article 11 of the Illinois Municipal Code, 65 ILCS 5/11-135-1 *et seq.*, and the Water Commission Act of 1985, 70 ILCS 3720/0.01 *et seq.* (the “Acts”).

WITNESSETH:

WHEREAS, the Commission has been organized under the Acts to supply water within its territorial limits; and

WHEREAS, the Village currently owns and operates a municipal drinking water system (“Oswego Unit System”) served by wells that extract source water from the Ironton-Galesville aquifer; and

WHEREAS, the Village is within the territorial limits of the Commission; and

WHEREAS, the Village intends to change from the Ironton-Galesville groundwater source to Lake Michigan source water, through a Water Purchase and Sale Contract with the DuPage Water Commission, and has applied for and received a Lake Michigan Water Allocation Permit (“Permit”) from the State of Illinois Department of Natural Resources, Office of Water Resources; and

WHEREAS, the Village has conducted extensive study and has concluded that the most sustainable alternative water source to serve the Village through the municipal waterworks system currently serving the Village, as well as any extensions or improvements of that system, is Lake Michigan water from the Commission; and

WHEREAS, the Commission owns and maintains a waterworks system as a supplier of

Lake Michigan water to member customers that contract for such service (“Commission’s Waterworks System”); and

WHEREAS, the Village is seeking to obtain water for its residents beginning in 2028 from the Commission in the incorporated areas within the Village (the “Service Area”); and

WHEREAS, the Village seeks to connect to Lake Michigan through the Commission; and

WHEREAS, the Commission has entered into a water supply contract with the City of Chicago to purchase Lake Michigan water sufficient to meet the water supply needs of the Commission and its customers; and

WHEREAS, the Commission’s water supply contract with the City of Chicago is set to expire in 2041 and the Commission is currently: (1) exploring an alternative solution to obtaining Lake Michigan water; and (2) in discussions and negotiations with the City of Chicago for a new water supply agreement; and

WHEREAS, to carry out their duties and responsibilities, and desire to create a method of providing an adequate supply of Lake Michigan water to the Oswego Unit System, the Commission, and the Village, concurrent with this Agreement, are entering into the Water Purchase and Sale Contract dated October 17, 2024, WaterLink Project Escrow Intergovernmental Agreement, and an Intergovernmental Agreement Concerning Development of Connection Facilities to Implement Water Service; and

WHEREAS, to become a member of the Commission and comply with the Water Purchase and Sale Contract, the Village must pay its proportional share of the costs for the property owned by the Commission (the “Capital Cost Recovery Charge”); and

WHEREAS, the Commission previously enacted Resolution R-79-04 allowing the Commission the ability to finance the Capital Cost Recovery Charge for potential Subsequent

Customers (customers other than its original customers) requesting such accommodation on a case-by case basis; and

WHEREAS, the matters set forth in this Agreement will serve the public interest, and the Commission and the Village deem it to be in each of their best interests for the Commission to provide financing to the Village for the money necessary to pay the Capital Cost Recovery Charge and enter into this Agreement; and

WHEREAS, pursuant to Section 10 of Article VII of the Illinois Constitution of 1970, the provisions of the Intergovernmental Cooperation Act, 5 ILCS 220/1 *et seq.*, and other applicable authority, the Commission and the Village are authorized to enter into this Agreement.

NOW, THEREFORE, in consideration of the foregoing and the mutual covenants and agreements hereinafter set forth, the Commission and the Village hereby agree as follows:

SECTION 1. PREAMBLES

The foregoing recitals are by this reference incorporated herein and made a part hereof as if fully set forth herein.

SECTION 2. COMMISSION FINANCING

A. **Capital Cost Recovery Financing.** The Commission will, after the execution and delivery of this Agreement, provide financing to the Village in the amount of \$11,047,790.00 (the “Capital Cost Recovery Amount”).

B. Payment Terms.

1. The Village will pay the Commission the principal balance of the Capital Cost Recovery Amount in 360 monthly installments, commencing at the time the first payment is due under Subsection 7M in the Water Purchase and Sale Contract (the “Monthly Payment Date”), and continuing in successive monthly installments on each Monthly Payment Date, with the

final payment of any principal, if not sooner paid, on the 360th Monthly Payment Date. Each of the 360 monthly installments of principal for the Capital Cost Recovery Amount will be in the amount of \$30,688.31, except that the final payment will be in the amount of \$30,686.71.

2. Interest on the unpaid principal balance of the Capital Cost Recovery Amount, will accrue at the rate of zero percent (0%) per annum.

C. Tender of Capital Cost Recovery Amount Payments. Payments of the principal of and interest will be made in lawful money of the United States of America in federal or other immediately available funds.

D. Asset-in-Kind Contribution. To the extent the Village agrees to pay for a portion of the increase in size of the primary 48” western pipeline (commencing at Book Road and 75th Street and extending west of the Fox River to a termination point at Orchard Road, also known as “TW 6/25” in the DWC naming convention), from the baseline pipe size to 54”, the value of that contribution by the Village will be mutually agreed upon and set forth in a separate agreement between the Commission and the Village before the closing of the WIFIA Loan.

E. Covenants. The covenants set forth in Subsections 9A, 9B, 9C, and 9D of the Water Purchase and Sale Contract are incorporated into this Agreement by reference.

SECTION 3. DEFAULTS AND REMEDIES

A. Commission Defaults. The occurrence of the following will constitute a default by the Commission under this Agreement: The failure by the Commission to observe and/or perform any covenant, condition, and/or agreement on its part to be observed and/or performed under this Agreement, and the continuation of said failure for thirty (30) days after the Commission’s receipt of written notice thereof from the Village. However, if said failure cannot be remedied by the Commission within said thirty (30) day period and the Commission has diligently pursued the

resolution of the failure during said thirty (30) days, the period will be extended by such additional time as may be reasonably required by the Commission to cure or correct said failure. In no event will the period be extended by more than ninety (90) days. In the event of a default by the Commission under this Agreement, the Village will have the same remedies as are provided for, and only the remedies provided for, in the Water Purchase and Sale Contractt for a default by the Commission.

B. Village Defaults. The occurrence of the following will constitute a default by the Village under this Agreement:

1. The failure by the Village to observe and/or perform any covenant, condition, and/or agreement on its part to be observed and/or performed under this Agreement, and the continuation of said failure for thirty (30) days after the Village's receipt of written notice thereof from the Commission. However, if said failure cannot be remedied by the Village within said thirty (30) day period and the Village has diligently pursued the resolution of the failure during said thirty (30) days, the period will be extended by such additional time as may be reasonably required by the Village to cure or correct said failure. In no event will the period be extended by more than ninety (90) days. In the event of a default by the Village under this Agreement, the Commission will have the same remedies as are provided for, and only the remedies provided for, in the Water Purchase and Sale Contract for a default by the Village;
2. A default under the October 17, 2024 Intergovernmental Agreement Concerning Development of Connection Facilities to Implement Water Service ; or

3. A default under the October 17, 2024 WaterLink Project Escrow Intergovernmental Agreement.

In the event of a default by the Village, the Commission will: (i) be paid its reasonable attorneys' fees and costs incurred in connection with that default, in addition to any attorneys' fees and costs incurred in enforcing the terms of this Agreement; (2) be entitled to the right to enforce a lien against all income derived from the Oswego Unit System, other than that income necessary to pay any loans to the State of Illinois or its agencies for the construction of the Oswego Unit System, until the Village's Capital Cost Recovery Amount and any amounts due from the Village under the WaterLink Project Escrow Intergovernmental Agreement are paid back in full; and (3) will have the same remedies as are provided for in the Water Purchase and Sale Contract for a default by the Village.

C. Force Majeure. In case by reason of a force majeure event, either party to this Agreement will be rendered unable wholly or in part to carry out its obligation under this Agreement, then if such party will give notice and full particulars of such force majeure event in writing to the other party within a reasonable time after occurrence of the event or cause relied on, the obligation of the party giving such notice, so far as it is affected by such force majeure event, will be suspended during the continuance of the inability then claimed, but for no longer period, and any such party will endeavor to remove or overcome such inability with all reasonable dispatch. The term "force majeure event" as employed in this Agreement will mean acts of God, strikes, lockouts, or other industrial disturbances, acts of public enemy, orders of any kind of the Government of the United States, of the State of Illinois, or of any civil or military authority, insurrections, riots, epidemics, pandemics, landslides, lightning, earthquakes, fires, hurricanes, storms, floods, washouts, droughts, arrests, restraints of government and people, civil disturbances, explosions, breakage or accidents to machinery, pipelines, canals, or tunnels, partial or entire

failure of water supply, and inability on the part of the Commission or of the Village to deliver Lake Michigan water, or of the Village to receive Lake Michigan water, on account of any other causes not reasonably within the control of the party claiming such inability. The settlement of strikes and lockouts will be entirely within the discretion of the party having the difficulty, and the above requirement that any “force majeure event” will be remedied with all reasonable dispatch will not require the settlement of strikes and lockouts by acceding to the demands of the opposing party or parties when such settlement is unfavorable to it in the judgment of the party having the difficulty.

SECTION 4. LEGAL RELATIONSHIPS AND REQUIREMENTS

A. Supplemental Agreement. This Agreement will be deemed to supplement the Water Purchase and Sale Contract in connection with the supply of Lake Michigan water to the Oswego Unit System. If there is any other conflict or inconsistency between the terms of this Agreement and the terms of the Water Purchase and Sale Contract, then the terms of this Agreement will control. The Village will at all times comply with all terms and conditions of the Water Purchase and Sale Contract, except as otherwise provided in this Agreement.

B. Term of Agreement. This Agreement will continue in full force and effect from the Effective Date until the Capital Cost Recovery Amount is paid in full by the Village.

C. Cooperation and Further Agreements. The Commission and the Village agree to cooperate in good faith throughout the term of this Agreement to implement the letter and spirit of the provisions set forth in this Agreement.

D. Assignment. This Agreement may not be assigned by any party, in whole or in part, without the prior written consent of the other party.

E. Notices. Any notices under this Agreement will be personally delivered, delivered by the deposit thereof in the U. S. Postal Service, postage prepaid, registered, or certified, return

receipt requested, or by overnight courier service to the Party at the address listed below or at another address hereafter designated by notice, or by email transmission. Any such notice will be deemed to have been delivered and given upon personal delivery or delivery by a nationally recognized overnight courier service, or deposit with the United States Postal Service or upon receipt of written confirmation that facsimile or email transmission has been successfully completed:

If to the Commission:

Paul D. May, P.E., General Manager
DuPage Water Commission
600 E. Butterfield Road
Elmhurst, IL 60126
Email: may@dpwc.org

With a copy to:

Phillip A. Luetkehans
Luetkehans, Brady, Garner & Armstrong
2700 International Drive, Suite 305
West Chicago, IL 60185
Email: pal@lbgalaw.com

If to the Village:

Village Administrator
Village of Oswego
100 Parkers Mill
Oswego, IL 60543
Email: info@oswegoil.org

With a copy to:

David J. Silverman
Village Attorney
Mahoney, Silverman, & Cross, LLC
126 South Main Street
Oswego, Illinois 60543

With a copy to:

Irene Schild Caminer
Caminer Law, LLC
2612 W. Sunnyside Ave.
Chicago, IL 60625
Email: Irene@caminerlaw.com

By notice complying with the requirements of this Section 4.E, the Commission and the Village each will have the right to change the address or addressee or both for all future notices to it, but no notice of a change of address will be effective until actually received.

F. No Oral Agreements. No oral agreements exist by or between the Commission and the Village with respect to this Agreement, nor was the making and execution of this Agreement induced by any representation, statement, warranty, agreement, or action other than those expressed or explicitly referenced in this Agreement.

G. No Waiver. No course of dealing or failure of the Commission or the Village to enforce strictly any term, right, or condition of this Agreement will be construed as a waiver of such term, right, or condition. No express waiver of any term, right, or condition of this Agreement will operate as a waiver of any other term, right, or condition.

H. No Third-Party Beneficiaries. This Agreement is entered into solely for the benefit of the contracting parties, and nothing in this Agreement is intended, either expressly or impliedly, to provide any right or benefit of any kind whatsoever to any person or entity who is not a party to this Agreement, or to acknowledge, establish, or impose any legal duty to any third party.

I. Governing Law and Venue. This Agreement will be governed by and construed exclusively under the applicable laws, but not the conflict of laws rules, of the State of Illinois. Venue for any litigation arising out of this Agreement will only be proper in the Eighteenth Judicial Circuit Court, DuPage County, Illinois.

J. Counterparts. This Agreement may be executed in several counterparts, each of which will be deemed to be an original, and all of which will constitute but one and the same instrument. Any such counterpart may be signed by one or more of the parties hereto so long as each of the parties hereto has signed one or more of such counterparts.

K. Authority. The person(s) executing this Agreement on behalf of the Parties hereto warrant that: (i) such the Village and the Commission are duly organized and existing; (ii) the individual signing is duly authorized to execute and deliver this Agreement on behalf of said Village or the Commission; (iii) by so executing this Agreement, such Village and the Commission are formally bound to the provisions and conditions contained in this Agreement; and (iv) the entering into this Agreement by the Village and the Commission does not violate any provision of any other agreement to which said Village and the Commission is bound.

L. Mutual Cooperation. The Village and the Commission acknowledge that it may be necessary to execute documents other than those specifically referred to herein in order to complete the objectives and requirements that are set forth in this Agreement. The Village and the Commission hereby agree to cooperate with each other by executing such other documents or taking such other actions as may be reasonably necessary to complete the objectives and requirements set forth herein in accordance with the intent of the Village and the Commission as evidenced by this Agreement.

M. Amendment. This Agreement is the entire agreement between the Village and the Commission regarding its subject matter and may not be changed or amended except pursuant to a written instrument signed by the Village and the Commission.

IN WITNESS WHEREOF, the Village and the Commission hereto have caused their respective corporate names to be subscribed hereto and their respective corporate seals to be affixed hereto and attested by their duly authorized officers.

ATTEST:

DuPAGE WATER COMMISSION

By: _____

By: _____

Its: _____

Its: _____

ATTEST:

VILLAGE OF OSWEGO

By: 

By: 

Its: Village Clerk

Its: Village President



Resolution #: R-60-24, R-61-24, R-62-24, R-63-24, R-64-24, and R-65-24

Account: N/A

Approvals: Author / Manager / Finance / Admin

REQUEST FOR BOARD ACTION

Date: 10/9/2024

Description: **Recommendation to Approve Water Purchase and Sales Agreement(s) and Capital Cost Recovery Charge Agreement(s) for the WaterLink communities of Oswego, Yorkville, and Montgomery**

Agenda Section: Administration Committee

Originating Department: Administration

I am pleased to present the WaterLink Customer Agreements for DWC Board consideration. The WaterLink communities have been working toward a new water source for over 10 years after becoming aware of impending water scarcity in the aquifer which provides their current supply. After extended study, the WaterLink partners (Oswego, Montgomery, and Yorkville), identified Lake Michigan source water delivered by the DuPage Water Commission as the preferred future source. This project will be one of the largest water projects in the Midwest, and will extend the DWC service area into Kendall counties with DWC water transmission infrastructure extending west of the Fox River upon completion.

The WaterLink communities have received IDNR allocations and have worked with DWC to fund Phase I and Phase II engineering over the last two years. During this period of time, the WaterLink communities have also been preparing financing instruments to fund the construction of the new infrastructure necessary to be constructed by DWC to convey water to the WaterLink communities. All project costs, including legal, engineering, property acquisition, construction, and commissioning will be funded by the WaterLink communities through a WaterLink Connection Facilities Agreement (R-66-24) and companion Project Escrow agreement (R-67-24), also included on this agenda.

The contract documents presented for approval have been crafted to provide continuity with previously approved Subsequent Customer Agreements to the greatest extent possible. DWC Legal Counsel and staff have worked closely with the WaterLink communities, their staff, and their legal counsel over many months to advance these documents for consideration. I wish to acknowledge and thank them for the significant effort that was provided to complete this task.

A summary of the primary elements of the Agreements is provided following:

Water Purchase and Sales Agreements (R-60-24, R-62-24, R-64-24):

The Water Purchase and Sale Agreement(s) have been constructed to provide a term that matches that of the other Contract Customers, ending February 24, 2064; and include language, terms, and conditions consistent with DWC Contract Customers. The project is scheduled for construction to commence in 2025 and to be commissioned in 2028. WaterLink communities will begin to access the new water source at that time, or as soon as permitted based upon achieving compliance with the IDNR water loss regulations.

Capital Cost Recovery Charge Agreements (R-61-24, R-63-24, R-65-24):

All new (subsequent) DWC customers are required to provide a Capital Cost Recovery Charge (aka “buy-in fee”) to ensure parity with the original Charter Customers which paid for the original DWC system upon formation. The Capital Cost Recovery Charged is determined by computing each customer’s pro-rata share by utilizing their IDNR allocation to calculate their demand as a percentage of the whole, and multiplying that percentage by the value of all DWC fixed assets as of the most recently audited fiscal year (FYE 2024). Based upon these computations, the Capital Cost Recovery Charges to be collected are as follows:

Oswego:	\$11,047,790
Montgomery:	\$ 9,998,815
Yorkville:	\$ 8,013,886

Companion Agreements:

In addition to the 1) Water Purchase and Sale Contract(s) and 2) Capital Cost Recovery Charge Agreement(s) for each of three WaterLink Communities, there are also two additional agreements for which there are four parties/signatories: the Village of Oswego, the Village of Montgomery, the United City of Yorkville, and the DuPage Water Commission. These items are included on the DWC October 17, 2024 DWC Agenda and are listed below:

- Resolution R-66-24: WaterLink Connection Facilities Intergovernmental Agreement
- Resolution R-67-24: WaterLink Project Escrow Agreement

Recommended Motion:

It is recommended that the DWC Board approve the Water Purchase and Sales Agreement(s) and the Capital Cost Recovery Charge Agreement(s) for the WaterLink communities of Oswego, Montgomery, and Yorkville.

DUPAGE WATER COMMISSION

RESOLUTION NO. R-62-24

A RESOLUTION APPROVING A WATER PURCHASE AND SALE CONTRACT WITH THE UNITED CITY OF YORKVILLE

WHEREAS, the Commission was formed and exists pursuant to the Water Commission Act of 1985, 70 ILCS 3720/0.01 et seq., and Division 135 of Article 11 of the Illinois Municipal Code, 65 ILCS 5/11-135-1 et seq., for the purpose of securing an adequate source and supply of water for its customers; and

WHEREAS, the Village of Montgomery (“Montgomery”), the Village of Oswego (“Oswego”) and the United City of Yorkville (“Yorkville”) (collectively the “Municipalities”) desire to supply Lake Michigan water to their residents by connecting to the Commission’s waterworks system (the “Project”); and

WHEREAS, the Commission and Yorkville have negotiated an Intergovernmental Agreement Concerning Capital Cost Recovery Charge and a Water Purchase and Sale Contract for the Project; and

WHEREAS, concurrently with the enactment of this Resolution, the Commission and the Municipalities are entering into an Intergovernmental Agreement Concerning Development of Connection Facilities to Implement Water Service for the Project; and

WHEREAS, concurrently with the enactment of this Resolution, the Commission and the Municipalities are entering into a WaterLink Project Escrow Intergovernmental Agreement with the Municipalities for the Project; and

WHEREAS, the Commission deems it to be in the best interests of the Commission and the public to complete the Project and enter into the Water Purchase and Sale Contract with Yorkville.

NOW, THEREFORE, BE IT RESOLVED by the Board of Commissioners of the DuPage Water Commission as follows:

SECTION ONE: The Board of Commissioners of the DuPage Water Commission hereby approves the Water Purchase and Sale Contract with the United City of Yorkville attached hereto as Exhibit 1 and

authorizes the Chairman to execute the Water Purchase and Sale Contract on behalf of the DuPage Water Commission and to take whatever steps necessary to effectuate the terms of said agreement.

SECTION TWO: This Resolution shall be in full force and effect after passage and approval as required by law.

	Aye	Nay	Absent	Abstain
Bouckaert, D.				
Cuzzone, N.				
Fennell, J.				
VACANT	_____			
Novotny, D.				
Pruyn, J.				
Romano, K.				
Rush, K.				
Russo, D.				
Saverino, F.				
Suess, P.				
Van Vooren, D.				
Zay, J.				

ADOPTED THIS _____ DAY OF _____, 2024.

James F. Zay, Chairman

ATTEST:

Danna Mundall, Clerk

Board/Resolutions/2024/R-62-24.docx

EXHIBIT 1

DUPAGE WATER COMMISSION

WATER PURCHASE AND SALE CONTRACT

Between

The DuPage Water Commission

and

The United City of Yorkville

FOR THE UNITED CITY OF YORKVILLE

October 17, 2024

**DUPAGE WATER COMMISSION
WATER PURCHASE AND SALE CONTRACT
WITH THE UNITED CITY OF YORKVILLE**

Table of Contents

	Page
SECTION 1. PREAMBLES	5
SECTION 2. DEFINITIONS	5
SECTION 3. WATER SUPPLY	16
A. Agreement to Sell and Purchase	16
B. Beginning of Obligations to Deliver and Receive Lake Water	16
C. Limits on Supply	17
D. Emergency or Maintenance Turn-Off	17
E. Curtailment; Emergency Use of Other Sources	18
F. Water Quality	19
SECTION 4. DELIVERY; STORAGE	19
A. Yorkville Unit System Connection Facilities	19
B. Storage	20
C. Metering of Shallow Wells	21
D. Surges and Back-Flows	21
E. Maintenance of System; Water Quality; Prevention of Waste	22
SECTION 5. MEASURING EQUIPMENT	22
A. Metering Station and Instrumentation	22
B. Records	24
C. Calibration	24
D. Check Meters	25
E. Meter Malfunctions	25
F. Removal of Metering Station and SCADA System Facilities	26
SECTION 6. UNIT OF MEASUREMENT	27
SECTION 7. PRICES AND TERMS OF PAYMENT	27
A. Operation and Maintenance Costs Payment	27
B. Fixed Costs Payment	27
C. Connection Facilities Cost Payment	29
D. Capital Cost Recovery Charge Payment	30
E. Underconsumption Costs Payment	31

	Page
F. Default Shares	31
G. Bills and Due Date	32
H. Disputed Payments.....	32
I. Interest on Overdue Payments	33
J. Security Deposit.....	34
K. Prepayments.....	35
L. Enforcement of Provisions Hereof by Other Customers	37
M. Beginning of Obligation to Pay	37
 SECTION 8. SPECIAL CONDITIONS AND COVENANTS	 38
A. Construction of the Commission Connection Facilities; No Delay Damages; Supply of Lake Water	 38
B. Lake Water Only; Costs.....	39
C. Title to Lake Water	40
D. Emergency Supply	40
E. Covenants to Be Set Out in Bond Ordinance.....	40
F. Payments Hereunder are an Operational Expense of the Yorkville Unit System	 40
 SECTION 9. ADDITIONAL YORKVILLE COVENANTS	 41
A. Maintenance of Corporate Existence	41
B. Maintenance and Operation of Yorkville Unit System.....	41
C. Rate Covenant.....	42
D. Future Subordination of Obligations	43
E. General Covenant to Operate Properly	43
F. Accounting and Audit	43
G. Maintain Ownership of Yorkville Unit System	44
H. Insurance.....	44
I. Continue to Serve.....	45
J. Maintain Water Allocation	45
K. Release and Indemnification.....	45
L. Combining or Separating System Accounts	46
M. Rate of Withdrawal	46
N. Emergency Interconnections.....	46
 SECTION 10. SCHEDULE FOR COMPLETION OF VARIOUS FACILITIES	 49
A. Plans and Specifications for Yorkville Unit System Connection Facilities	 49
B. IEPA and Other Approvals for Yorkville Unit System Connection Facilities	50

	Page
C. Commencement of Construction of Yorkville Unit System	
Connection Facilities	50
D. Intentionally Omitted.....	50
E. Intentionally Omitted.....	50
F. Intentionally Omitted.....	50
G. Transfer of Property Rights	51
H. Commencement of Construction of Commission Connection Facilities	51
I. Delivery of Water for Start-Up Purposes	51
J. Illustrative Schedule of Events	52
SECTION 11. ASSIGNABILITY.....	53
SECTION 12. FORCE MAJEURE.....	53
SECTION 13. COMMISSION DEFAULTS	55
SECTION 14. YORKVILLE OBLIGATION UNCONDITIONAL.....	55
SECTION 15. COOPERATION IN CONSTRUCTION; EASEMENTS.....	56
SECTION 16. COOPERATION IN ISSUANCE OF BONDS.....	57
SECTION 17. REGULATORY BODIES	57
SECTION 18. OTHER WATER SUPPLIERS.	58
SECTION 19. NOTICES; EVIDENCE OF ACTIONS; WAIVER.....	58
A. Notices.....	58
B. Evidence of Actions	59
C. Waiver	59
D. Partial Invalidity	59
SECTION 20. EFFECTIVE DATE; TERMINATION; PAYMENT OF INTERIM COSTS; TERM.....	60
A. Effective Date.....	60
B. Commission Right to Terminate	60
C. Payment of Interim Costs	61
D. Term	62
SECTION 21. GOVERNING LAW AND VENUE.....	62
SECTION 22. MUNICIPAL BOUNDARIES.....	62

	Page
SECTION 23. MODIFICATIONS OR AMENDMENTS	63
SECTION 24. EXHIBITS INCORPORATED.....	63
SECTION 25. EXECUTION IN COUNTERPARTS	63

**DUPAGE WATER COMMISSION
WATER PURCHASE AND SALE CONTRACT WITH THE UNITED CITY
OF YORKVILLE
FOR THE UNITED CITY OF YORKVILLE UNIT SYSTEM**

This Water Purchase and Sale Contract (“Contract”), dated as of October 17, 2024, by and between the **DUPAGE WATER COMMISSION**, DuPage, Cook, and Will Counties, State of Illinois (the “Commission”), a county water commission and public corporation under Division 135 of Article 11 of the Illinois Municipal Code, 65 ILCS 5/11-135-1 *et seq.*, and the Water Commission Act of 1985, 70 ILCS 3720/1 *et seq.* (collectively, the “Acts”), and the **UNITED CITY OF YORKVILLE**, Kendall County, Illinois, a municipal corporation duly organized and existing under the laws of the State of Illinois (“Yorkville”);

WITNESSETH:

WHEREAS, the Commission has been organized under the Acts to supply water within its territorial limits; and

WHEREAS, the Commission owns and maintains a waterworks system as a supplier of Lake Michigan water to member customers that contract for such service; and

WHEREAS, Yorkville currently owns and operates a municipal drinking water system served by wells that extract source water from the Ironton-Galesville aquifer; and

WHEREAS, Yorkville is within the territorial limits of the Commission; and

WHEREAS, Yorkville, together with the Village of Oswego and the Village of Montgomery (collectively the “WaterLink Communities”), conducted extensive study

and concluded that the most sustainable alternative water source to serve the WaterLink Communities through the municipal waterworks systems currently serving the WaterLink Communities, as well as any extensions or improvements of those systems is Lake Michigan water from the Commission; and

WHEREAS, Yorkville (along with the WaterLink Communities) has applied for and received from the State of Illinois Department of Natural Resources, Office of Water Resources, a Lake Michigan water allocation permit for the Yorkville Unit System; and

WHEREAS, Yorkville is in the process of designing and constructing the conversion of its waterworks system that will be owned and operated by Yorkville and extended or improved from time to time to meet the potable water requirements of all residents and businesses to be served with water from Yorkville, which waterworks system is preliminarily depicted in Exhibit A attached to this Contract; and

WHEREAS, the Commission and the WaterLink Communities have entered into Escrow Agreements and have been taking steps to finance, study, engineer, design, and construct the facilities necessary for the WaterLink Communities to receive Lake Michigan water, and the Commission has been taking steps to study, finance, engineer, design, and construct the Commission Connection Facilities (as defined herein) to deliver Lake Michigan water to the WaterLink Communities; and

WHEREAS, contemporaneously with this Agreement, the WaterLink Communities and the Commission are entering into a WaterLink Project Escrow Intergovernmental Agreement, an Intergovernmental Agreement with the United City

of Yorkville Concerning Capital Cost Recovery Charge, and an Intergovernmental Agreement Concerning Development of Connection Facilities to Implement Water Service; and

WHEREAS, the WaterLink Communities have started Optimal Corrosion Control Treatment (OCCT) Studies of their water systems to be filed with the Illinois Environmental Protection Agency. The Commission and Yorkville acknowledge that the OCCT Study, including recommendations for infrastructure improvements that may be needed as a result of recommendations for optimized corrosion control treatment, will not be completed and reviewed by IEPA until approximately October 2025; and

WHEREAS, Yorkville and the Commission recognize that construction may begin pending the results of the OCCT Study; and

WHEREAS, Yorkville desires that its waterworks system preliminarily depicted in Exhibit A attached to this Contract as well as any extensions or improvements of that system (the "Yorkville Unit System") be served with water from the Commission beginning sometime in 2028 as mutually agreed to by the parties; and

WHEREAS, the Commission has entered various water supply contracts with the City of Chicago to purchase Lake Michigan water sufficient to meet the water supply needs of the Commission and its customers (the "Water Supply Contract") and most recently in 2024 and extends until 2041; and

WHEREAS, at some point during the term of this Contract, the Commission may build alone or with others a water treatment, distribution, and transmission system to

obtain Lake Michigan water directly from Lake Michigan that will serve the Commission; and

WHEREAS, the Commission has issued and sold and may further propose to issue and sell Bonds (as defined in Section 2 below) from time to time during the term of this Contract in sufficient amounts for the payment of the costs of its project of acquiring, designing, constructing, and maintaining its Waterworks System (as defined in Section 2 below); and

WHEREAS, such Bonds have been and may be issued in the future from time to time by the Commission pursuant to Bond Ordinances (as defined in Section 2 below) adopted by the Commission; and

WHEREAS, pursuant to the Acts, Article VII, Section 10 of the Illinois Constitution of 1970, the Intergovernmental Cooperation Act, 5 ILCS 220/1 *et seq.*, and the Public Utilities Act, 220 ILCS 5/1 *et seq.* as amended, the Commission and Yorkville are authorized to enter into this Contract; and

WHEREAS, by the execution of this Contract, Yorkville is surrendering none of its rights to the ownership and operation of the Yorkville Unit System, except as expressly provided for, and only to the limited extent so provided for, in this Contract, and Commission is surrendering none of its rights to the ownership and operation of its Waterworks System, but each asserts its continued right to operate such systems; and

WHEREAS, Yorkville recognizes that the Commission may use this Contract as the basis, in part, for obtaining loans from time to time to be evidenced by the issuance

of its Bonds; and for payment of the principal of and the premium, if any, and interest on such Bonds; and as the means for the payment of its maintenance and operating expenses; and for such purposes as may be authorized by applicable statutes or required in any Bond Ordinance adopted by the Commission authorizing issuance of Bonds; and

WHEREAS, Yorkville recognizes that the Commission may in the future enter into contracts with other customers that are members of or may join the Commission.

NOW, THEREFORE, in consideration of the foregoing recitals and of the mutual covenants and agreements herein contained, the Commission and Yorkville hereby agree as follows:

SECTION 1. PREAMBLES.

The preambles hereto are hereby incorporated herein by this reference and are made fully a part of this Contract.

SECTION 2. DEFINITIONS.

The following words and phrases shall have the following meanings when used in this Contract.

- A. "Aggregate Costs" means Operation and Maintenance Costs, Fixed Costs, and Underconsumption Costs, collectively, as defined herein.
- B. "Alternate Delivery" means the delivery of Lake Water purchased by Yorkville from the Commission to the Yorkville Unit System through facilities owned by a Contract Customer (commonly referred to as "Wheeling").
- C. "Asset-In-Kind Amount" means the differential amount, if any, that Yorkville pays

for a portion of the increase in size of the primary 48" western pipeline (commencing at Book Road and 75th Street and extending west of the Fox River to a termination point at Orchard Road, also known as "TW 6/25" in the DWC naming convention) from the baseline pipe size to 54". The Commission and Yorkville will mutually agree in a separate document to be executed prior to the closing of the WIFIA Loan on the value of the contribution.

D. "Average Contract Customer Rate Per 1,000 Gallons" means Total Contract Customer Revenue divided by Total Contract Customer Use.

E. "Bond Ordinances" means all of the Commission's ordinances and resolutions under which the Commission has or will authorize the issuance of, or issue, Bonds.

F. "Bonds" means Revenue Bonds and Other Bonds.

G. "Capital Cost Recovery Charge" means the amount necessary, pursuant to Section 0.02 of the Water Commission Act of 1985 (as added by Public Act 093-0226) and Commission Resolution No. R-79-04, entitled "A Resolution Expressing the Policy of the DuPage Water Commission Regarding the New Subsequent Customer Pricing Methodology," to recover Yorkville's proportionate share of Original Capital Costs less Rebates, where Yorkville's proportionate share of Original Capital Costs less Rebates is that proportion of Original Capital Costs less Rebates which Yorkville's Full Water Requirements for 2022 and 2023 as reported by Yorkville to the IEPA bears to the sum of the Full Water Requirements or Minimum Take or Pay Requirements (as defined in the Contract Customer Contract), as applicable, of all of the Commission's Contract Customers for such two years which the parties agree shall be \$8,013,886.00

based on the method of calculating such amount illustrated in Exhibit E attached to this Contract.

H. "Charter Customer Facilities" means all of the feeder mains, metering stations, and pressure adjusting stations constructed as of May 1, 1992, solely for the purpose of initially connecting the Charter Customers to the Waterworks System.

I. Intentionally Omitted.

J. "Charter Customers" means the units of local government (not including the Commission) that are parties to the Charter Customer Contract, excluding, however, any such unit of local government whose rights and obligations under such Contract have been terminated, including without limitation the United City of Yorkville.

K. "Commission" means the DuPage Water Commission, DuPage, Cook, and Will Counties, State of Illinois.

L. "Commission Connection Facilities" means the portions of the Waterworks System constructed by the Commission to initially connect the WaterLink Communities including the Yorkville Unit System to the existing Waterworks System, which facilities are depicted in the preliminary plans attached as Exhibit B-2 to this Contract, as such facilities may be relocated, replaced, extended, or improved and may be used in the service of other customers from time to time. The Commission Connection Facilities include, among other items, metering station(s), including pipelines and equipment appurtenant thereto, and SCADA System facilities attributable to the Yorkville Unit System, including equipment appurtenant thereto.

M. "Connection Facilities" means the Yorkville Unit System Connection Facilities

and the Commission Connection Facilities.

N. "Connection Facilities Cost" means the full actual cost incurred by the Commission in connection with (i) the design, bidding, contracting, managing, and actual construction, installation, removal, relocation, replacement, extension, or improvement of the Connection Facilities, including without limitation equipment required for the operation of the Connection Facilities and all administrative, financing, supervisory, inspection, engineering, surveying, and legal fees, costs, and expenses associated therewith; (ii) the acquisition and divestment of lands, easements, and rights of way over lands and waters necessary for the construction, installation, removal, relocation, replacement, extension, or improvement of the Connection Facilities, and all administrative, title, surveying, and legal fees, costs, and expenses associated therewith; and (iii) the review and processing of plans and agreements for the construction, installation, removal, relocation, replacement, extension, or improvement of the Connection Facilities and in connection with the negotiation, preparation, consideration, and review of this Contract, including without limitation all legal, engineering, consulting, and administrative fees, costs, and expenses associated therewith; except as any of the above are included in Operation and Maintenance Costs.

O. "Contract" means this Water Purchase and Sale Contract.

P. "Contract Customer Contract" means the Water Purchase and Sale Contract between the Commission and the Contract Customers dated as of January 18, 2024.

Q. "Contract Customers" collectively means the Contract Customers, Yorkville, and

any other entity with whom the Commission has entered into, or may in the future enter into, a contract or agreement for the sale by the Commission of Lake Water to that entity, except only contracts and agreements providing for the delivery of Lake Water during times of emergency only.

R. "Days" means calendar days.

S. "Determination Date" means the last day of December immediately preceding the Interest Period for which the Earned Interest Rate pursuant to this Contract is being calculated, but the effective date of any change in the Earned Interest Rate shall, for purposes hereof, be the first day of May following such Determination Date.

T. "Earned Interest Rate" means, with respect to each Interest Period under this Contract, the highest monthly average yield to maturity interest rate earned by the Commission (total funds) as reported monthly on the Commission's Schedule of Investments for the immediate preceding fiscal year (May 1 – April 30) as determined by the Commission, which determination shall be conclusive and binding upon Yorkville absent manifest error, but the effective date of any change in the Earned Interest Rate shall, for purposes hereof, be the first day of May following such Determination Date.

U. "Fiscal Year" means the fiscal year of the Commission.

V. "Fixed Costs" means an amount sufficient at all times to pay the principal of and the premium, if any, and interest on any Revenue Bonds, to provide reserves required therefor, to provide an adequate depreciation fund for the Waterworks System, to comply with the covenants of all Revenue Bond Ordinances, and to pay reasonable

capital costs necessary to carry out the corporate purposes and powers of the Commission; except as any of the above are included in Operation and Maintenance Costs.

W. "Full Water Requirements" means, (i) as it applies to calculating Yorkville's Capital Cost Recovery Charge, the amount of water necessary to meet the potable water requirements of all then current customers served by the Yorkville Unit System at the time Yorkville's Capital Cost Recovery Charge is being calculated, (ii) as it applies to the Yorkville Unit System for all other purposes of this Contract, the amount of water necessary from time to time to meet the potable water requirements of all then current customers served by the Yorkville Unit System, and (iii) as it applies to other Contract Customers of the Commission, such Contract Customers' full water requirements as defined in their respective contracts with the Commission.

X. "Interest Period" means (i) initially, the period commencing on the first date on which Yorkville first becomes obligated to make payments under Subsection 7.D of this Contract and ending on the next succeeding first day of May and (ii) thereafter, each period commencing on the last day of the next preceding Interest Period and ending on the next succeeding first day of May; provided, however, that any Interest Period that otherwise extends beyond May 1, 2058, shall end on February 24, 2064.

Y. "Lake Water" means potable, filtered water drawn from Lake Michigan.

Z. "Operation and Maintenance Costs" means amounts payable by the Commission under the Water Supply Contract, except Underconsumption Costs, and all expenses incurred in the administration, operation, and maintenance of the Waterworks System

and the accumulation of reserves related to payment of said costs. Operation and Maintenance Costs in any month shall be at least equal to the amount required to be deposited by the Commission in that month into the operation and maintenance funds or accounts created under all Revenue Bond Ordinances.

AA. "Original Capital Costs" means all costs paid by the Commission for property owned by the Commission, as of April 30, 2024, without reduction for depreciation, including actual costs of construction, engineering, and capitalized interest on assets in service and under construction but excluding the cost of constructing the Charter Customer Facilities and financing costs other than interest capitalized in accordance with Generally Accepted Accounting Principles.

BB. "Original Revenue Bonds" means the Series 1987 Revenue Bonds, originally issued in the amount of \$200,000,000 pursuant to Ordinance No. 0-1-87 adopted January 15, 1987, and the Series 1993 Water Refunding Revenue Bonds, originally issued in the amount of \$182,755,000 pursuant to Ordinance No. 0-8-93 adopted April 8, 1993, and any other Revenue Bonds that may in the future be issued to refund or refinance all or any portion of the indebtedness represented by said Series 1987, 1993, 2003, and 2013 Revenue Bonds. As of the date of this Contract, all of the Original Revenue Bonds are fully paid and retired.

CC. "Yorkville" means the United City of Yorkville, located in Kendall County, State of Illinois.

DD. "Yorkville's Base Rate" means a water rate stated as dollars or cents per 1,000 gallons that is calculated by (i) the sum of all Operation and Maintenance Cost payments, all Fixed Costs payments, all Connection Facilities Cost payments, and all

Capital Cost Recovery Charge payments under the Contract Customer Contract estimated to be made by Yorkville pursuant to this Contract in the Fiscal Year for which Yorkville's Base Rate pursuant to this Contract is being calculated and (ii) dividing the resulting amount by the total amount of Lake Water, stated in 1,000 gallon units, estimated to be delivered to Yorkville in said Fiscal Year.

EE. "Yorkville Unit System" means the waterworks system described in Exhibit A attached to this Contract as well as any extensions or improvements of that system acquired by Yorkville and used for the purpose of providing and transmitting water to its customers.

FF. "Yorkville Unit System Connection Facilities" means those portions of the Yorkville Unit System, lying downstream from the Point of Delivery, to be constructed pursuant to this Contract by Yorkville at its expense to initially connect the Yorkville Unit System to the Waterworks System, which facilities are depicted in the preliminary plans attached as Exhibit B-1 to this Contract, as such facilities may be relocated, replaced, extended, or improved from time to time. The Yorkville Unit System Connection Facilities include, among other items, the pressure adjusting station(s) described in Subsection 4.A of this Contract and pipeline and equipment appurtenant thereto.

GG. "Other Bond Ordinances" means all of the Commission's ordinances and resolutions under which the Commission has or may authorize the issuance of, or issue, Other Bonds.

HH. "Other Bonds" means all of the Commission's debt obligations that are not

Revenue Bonds, whether in the form of bonds, notes, or other evidence of indebtedness, in whatever original principal amount, together with any such additional non-revenue obligations authorized by statute to be issued by the Commission from time to time and refunding obligations issued to refund other such obligations.

II. "Point(s) of Delivery" means the point(s) at which the Lake Water delivered to Yorkville pursuant to this Contract leaves the Commission's Waterworks System and enters the Yorkville Unit System. A Point of Delivery shall be a point in the water main connecting the Commission's metering station(s) to Yorkville's pressure adjusting station(s) located downstream from the inside face of the outside wall or foundation of the Commission's metering station(s) a distance of 10 feet or where such water main enters the outside face of the outside wall or foundation of Yorkville's pressure adjusting station(s), whichever is closer to the Commission's metering station(s).

JJ. "Prime Rate" means the base corporate rate of interest then most recently announced by the largest commercial bank, measured in terms of total assets, located and doing banking business in the State of Illinois, which rate may or may not be said bank's lowest rate of interest charged by said bank for extensions of credit to debtors. The effective date of any change in the Prime Rate shall, for purposes hereof, be the effective date stated in the public announcement of said bank.

KK. "Rebates" means rebates formally declared as such by Commission Resolution as of the month prior to the month in which Yorkville first becomes obligated to make payments under Subsection 7.D of this Contract. As of the date of this Contract, the

Commission has formally declared \$106,326,287.00 in Rebates pursuant to Resolution Nos. R-19-94, R-21-95, R-15-96, R-24-97, R-18-98 and R-28-07.

LL. "Revenue Bond Ordinances" means all of the Commission's resolutions under which the Commission has or will authorize the issuance of, or issue, Revenue Bonds.

MM. "Revenue Bonds" means all of the Commission's debt obligations, including the Original Revenue Bonds, that are payable from the revenues of the Waterworks System, whether in the form of bonds, notes, or other evidence of indebtedness, in whatever original principal amount, together with any such additional revenue obligations authorized by statute to be issued by the Commission from time to time and refunding revenue obligations issued to refund other such obligations.

NN. "SCADA System" means the Supervisory Control and Data Acquisition System of the Commission that provides an integrated control, communication, and security system for the Waterworks System, including data processing, management, transfer, and exchange; central operation; system control and monitoring; and operator-machine interfacing.

OO. "Trustee" means a trustee provided in a Bond Ordinance.

PP. "Underconsumer" means, for any given year, a Contract Customer of the Commission that takes less Lake Water in such year than such Contract Customer's Water Allocation times 365 times the Underconsumption Ratio for such year.

QQ. "Underconsumption" means the amount by which the amount of Lake Water actually taken by a Contract Customer of the Commission is less than the Underconsumption Ratio times such Contract Customer's Water Allocation times 365.

RR. "Underconsumption Costs" means any amount that the Commission is obligated

to pay under the Water Supply Contract solely by reason of failure to accept delivery of the minimum quantity of Lake Water that the Commission is obligated to purchase under the Water Supply Contract.

SS. "Underconsumption Ratio" means, for any given year, (i) the minimum amount of Lake Water required to be taken by the Commission under the Water Supply Contract divided by (ii) the sum of the Water Allocations of all Contract Customers of the Commission times 365.

TT. "Water Allocation" means, as it applies to other Contract Customers of the Commission, such Contract Customers' water allocation as defined in their respective contracts with the Commission, and, as it applies to Yorkville, the sum of Yorkville's allocations and allowable excesses from time to time of Lake Water for the Yorkville Unit System pursuant to the Level of Lake Michigan Act, as amended from time to time (See State of Illinois Department of Transportation, Division of Water Resources Decision on 1989 Allocation Review, Order No. LMO 89-2 and subsequent orders of the State of Illinois Department of Transportation, Division of Water Resources, or the successor to its responsibilities, the State of Illinois Department of Natural Resources, Office of Water Resources); and such other amounts of Lake Water as Yorkville may lawfully take for the Yorkville Unit System. At any time when the Full Water Requirements of the Yorkville Unit System shall exceed the Water Allocation for the Yorkville Unit System, then "Water Allocation" shall mean the Full Water Requirements of the Yorkville Unit System for all purposes of this Contract.

UU. "Water Supply Contract" means the water supply contract, dated March 19, 1984,

between the Commission and the City of Chicago, Illinois, as amended, supplemented, or extended from time to time, or any alternative water supply agreement, and most recently in 2024 and extends until 2041.

VV. "Waterworks System" means all the Commission's facilities, including land; easements; rights-of-way over lands and waters; pumping facilities, storage facilities, metering stations, and other facilities; mains; and pipelines acquired and used for the purposes of providing and transmitting Lake Water from the Lake Michigan water supply system to the Commission's customers. The Yorkville Unit System Connection Facilities are not part of the Waterworks System.

SECTION 3. WATER SUPPLY.

A. Agreement to Sell and Purchase. Subject to the provisions of this Contract, the Commission shall sell to Yorkville and Yorkville shall purchase from the Commission an amount of Lake Water necessary from time to time to serve the Yorkville Unit System's Full Water Requirements. The Commission's obligation to Yorkville to deliver Lake Water hereunder shall be limited, however, to a maximum annual amount equal to Yorkville's then current Water Allocation times 365 and to a maximum rate of Lake Water to the Yorkville Unit System in any one hour equal to 1.7 times Yorkville's then current Water Allocation divided by 24.

B. Beginning of Obligations to Deliver and Receive Lake Water. Unless this Contract is sooner terminated by the Commission pursuant to Subsection 20.B of this Contract, the Commission shall be obligated to deliver Lake Water to the Yorkville Unit System and Yorkville shall be obligated to receive at the Yorkville Unit System Lake Water delivered by the Commission immediately after completion of

construction of the Connection Facilities and the water storage capacity required pursuant to Subsection 4.B of this Contract; provided, however, that Yorkville shall have the right to receive Lake Water pursuant to this Contract prior to the completion of construction of the required storage capacity if such storage capacity has been substantially completed to the point where it is capable of serving its intended function or would be capable of serving its intended function except for the fact that painting or other finishing and restoration work are not complete.

C. Limits on Supply. The Commission shall use its best efforts to furnish Lake Water to Yorkville as hereinabove provided, but Yorkville acknowledges and agrees that the Commission's obligation hereunder is limited by:

- (i) The amount of Lake Water from time to time available to the Commission; and
- (ii) Provisions in contracts between the Commission and its Contract Customers and other customers related to curtailment and other limits on the supply of Lake Water; and
- (iii) The capacity of the Waterworks System; and
- (iv) Ordinary transmission loss, including standard metering error, between the Commission's source of supply and the Point of Delivery to the Yorkville Unit System; and
- (v) The other provisions of this Contract, including but not limited to Section 20.

D. Emergency or Maintenance Turn-Off. The Commission undertakes to use reasonable care and diligence to provide a constant supply of Lake Water as herein provided for but reserves the right at any time to turn off the flow of Lake Water in its mains for emergency and maintenance purposes. The Commission shall give notice not less than 48 hours in advance of any turn-off for maintenance purposes and it shall

give such notice as is reasonable under the particular circumstances of any turn-off for emergency purposes.

E. Curtailment; Emergency Use of Other Sources. If it becomes necessary for the Commission to limit its delivery of Lake Water to its customers for any reason, Yorkville shall be entitled, to the extent possible, to receive during such period of curtailment a pro rata share of available Lake Water as determined by the ratio of (i) the Yorkville Unit System's total Lake Water use during the prior Fiscal Year for other than start-up purposes pursuant to Subsection 10.I of this Contract to (ii) the sum of Lake Water use during the prior Fiscal Year of all of the Commission's customers entitled to Lake Water during such period of curtailment. Prior to the Commission's delivery of Lake Water to the Yorkville Unit System for a full Fiscal Year for other than start-up purposes pursuant to Subsection 10.I of this Contract, Yorkville shall be entitled, to the extent possible, to receive during such period of curtailment a pro rata share of available Lake Water as determined by the ratio of the Yorkville Unit System's Full Water Requirements during the prior Fiscal Year to the sum of (i) Lake Water use during the prior Fiscal Year of all of the Commission's other customers entitled to Lake Water during such period of curtailment and (ii) the Yorkville Unit System's Full Water Requirements during the prior Fiscal Year. Yorkville, in cases of emergency or when the Commission for whatever reason is unable to meet the Yorkville Unit System's Full Water Requirements, may, subject to the terms, conditions, and limitations set forth in Subsection 9.N of this Contract, serve its customers from any source; provided, however, that Yorkville shall continue to pay all

amounts due to the Commission hereunder during such period as if the Yorkville Unit System were receiving its Full Water Requirements from the Commission.

F. Water Quality. The Commission shall supply Yorkville with Lake Water of a quality commensurate to that furnished to the Commission's other Contract Customers, and meeting the requirements of any federal, State of Illinois, or local agency as shall have jurisdiction from time to time for the operation of public water supplies such as the Waterworks System. The Commission bears no responsibility for the contamination of Lake Water or deterioration of water quality occurring beyond the Points of Delivery to the Yorkville Unit System.

SECTION 4. DELIVERY; STORAGE.

A. Yorkville Unit System Connection Facilities. Yorkville shall receive its supply of Lake Water at the Yorkville Unit System Points of Delivery at pressures that will vary from time to time. Yorkville, at its own expense and pursuant to the schedule established in Section 10 of this Contract, shall site, design, construct, operate, maintain, and when necessary, replace the Yorkville Unit System Connection Facilities, including a pressure adjusting station immediately downstream from the Points of Delivery. Initial design and construction plans and specifications for the Yorkville Unit System Connection Facilities, and any future modifications thereof, shall be submitted in advance of construction or modification to the Commission for review and approval, which approval shall not be unreasonably withheld. In the event the Yorkville Unit System or the Yorkville Unit System Connection Facilities are to be relocated, replaced, extended, or improved at the request of the Commission, its

successor, other than those circumstances where the Commission is compelled to relocate the Yorkville Unit System or the Yorkville Unit System Connection Facilities for a non-Commission conflicting public infrastructure project or by State or Federal mandate, Yorkville will be entitled to reasonable and fair market value recovery for all costs without reduction for depreciation including actual costs of construction, engineering, and capitalized interest on assets in service and under construction and financing costs other than interest capitalized in accordance with Generally Accepted Accounting Principles.

B. Storage. Yorkville shall provide sufficient storage capacity within the Yorkville Unit System to store not less than two times the annual average daily water demand of the Yorkville Unit System; provided, however, that said requirement shall be reduced by (i) the amount of operable shallow well capacity (stated in gallons per hour) maintained by Yorkville in the Yorkville Unit System up to a maximum of 10 percent (10%) of said requirement plus (ii) an amount equal to the storage capacity maintained by the Commission in its Waterworks System multiplied by a fraction, the numerator of which is the annual average daily water demand of the Yorkville Unit System and the denominator of which is the total annual average daily water demands of all Contract Customers. The calculation of said water storage capacity requirement for the Yorkville Unit System is provided in Exhibit C attached to this Contract. In accordance with said requirement, Yorkville, at its own expense and pursuant to the schedule established in Section 10 of this Contract, shall construct for the Yorkville Unit System at least the amount of water storage capacity shown on Exhibit C to this Contract as the "Minimum Additional Required Storage." Such water storage capacity

shall be in addition to the amount of water storage capacity shown on Exhibit C to this Contract as the "Existing Storage" in the Yorkville Unit System. Yorkville shall properly maintain all such water storage capacity, including operable shallow well capacity, in good and serviceable condition. If at any time Yorkville's water storage capacity in the Yorkville Unit System, including its allowances for operable shallow well capacity and Commission storage capacity as provided above, falls below 1.9 times the annual average daily water demand of the Yorkville Unit System, then Yorkville, within 24 months after such level of deficiency is reached, shall construct additional water storage capacity within the Yorkville Unit System of sufficient quantity to increase the total storage capacity of the Yorkville Unit System, including its allowances for operable shallow well capacity and Commission storage capacity as provided above, to not less than two times the annual average daily water demand of the Yorkville Unit System.

C. Metering of Shallow Wells. Yorkville shall furnish, install, and maintain a meter on each of its operable shallow wells. All such meters shall be of standard make and shall be subject to inspection and examination by any employee or agent of the Commission at all reasonable times. Yorkville shall calibrate all such meters at least once in each Fiscal Year. Yorkville shall notify the Commission of the time, date, and place of each calibration at least five days in advance thereof, and a representative of the Commission shall have the right to observe any adjustments made to such meters in case any adjustments shall be necessary. The Commission shall have the right to place any or all of such meters under seal at any time.

D. Surges and Back-Flows. Yorkville's operation of its pressure adjusting

station shall not cause surges or back-flows into the Waterworks System, nor shall the operation of the Yorkville's pressure adjusting station cause the Waterworks System pressure to drop below 20 pounds per square inch. The Commission shall not be responsible for any damage to the Yorkville Unit System or the Yorkville Unit System Connection Facilities caused by the design, operation, or maintenance of the Connection Facilities.

E. Maintenance of System; Water Quality; Prevention of Waste. Yorkville shall operate the Yorkville Unit System and the Yorkville Unit System Connection Facilities in such a manner as at no time to place the Commission and the Waterworks System in jeopardy of failing to meet the regulations of any agency or governmental authority having jurisdiction over the Commission's operation of its Waterworks System. The Commission and Yorkville shall notify each other immediately of all emergency and other conditions which may directly or indirectly affect the Waterworks System, the Yorkville Unit System, the Connection Facilities, or the quantity or quality of the Lake Water received pursuant to this Contract.

SECTION 5. MEASURING EQUIPMENT.

A. Metering Station and Instrumentation. The Commission shall, pursuant to the timetable established in Section 10 of this Contract, furnish, and install at the Points of Delivery a metering station containing the necessary equipment and devices of a type meeting the standards of the American Water Works Association for measuring properly the quantity of Lake Water delivered under this Contract, including all structures as the Commission shall deem necessary to house such equipment and

devices. Such furnishing and installing of a metering station shall be done in substantial conformance with the preliminary plans therefor attached as Exhibit B-2 to this Contract, as such preliminary plans may be revised by mutual agreement of the Commission and Yorkville. The Commission shall own, operate, maintain, and replace such metering station and all equipment and structures related thereto.

The metering station shall be located at a site or sites selected and acquired by Yorkville, and title transferred to the Commission, free and clear of all liens, claims, encumbrances, and restrictions unless otherwise approved by the Commission in writing. Yorkville shall be responsible for maintaining the grounds and landscaping, including but not limited to shrubbery and other plantings, located on each site provided. Such sites shall be subject to reasonable review and approval of the Commission, without charge to the Commission and pursuant to the timetable established in Section 10 of this Contract, shall grant to the Commission all necessary and insured easements for such site(s) and access thereto to the reasonable satisfaction of the Commission in a form similar to that attached as Exhibit D to this Contract and satisfactory to the Commission's attorneys. Yorkville also shall grant to the Commission all necessary and insured easements for the appropriate location and installation of antennas and appurtenant facilities for the Commission's SCADA System attributable to the Yorkville Unit System on property owned by Yorkville or on property lying within the corporate limits of Yorkville, free and clear of all liens, claims, encumbrances, and restrictions unless otherwise approved by the Commission in writing. Such SCADA System antennas or facilities shall be installed on such

easements in a manner that will reduce so far as reasonably possible any interference with the telemetry of the Yorkville Unit System.

Yorkville shall have access to the metering station for examination and inspection at reasonable times, but the reading for billing purposes, calibration, and adjustment of the equipment therein shall be done only by the employees or agents of the Commission.

B. Records. For the purpose of this Contract, the official record of readings of each meter at the metering station shall be the journal or other record book of the Commission in its office in which the records of the employees or agents of the Commission who take the readings are or may be transcribed. Upon written request of Yorkville, the Commission will give Yorkville a copy of such journal or record book, or permit Yorkville to have access thereto in the office of the Commission during regular business hours.

C. Calibration. At least once in each Fiscal Year, the Commission shall calibrate its meters dedicated to measuring the Lake Water delivered to the Yorkville Unit System, in the presence of a representative of Yorkville, and the Commission and Yorkville shall jointly observe any adjustments that are made to the meters in case any adjustments shall be necessary. If any check meters have been installed, then such check meters shall be calibrated at least once in each Fiscal Year by Yorkville in the presence of a representative of the Commission, and the Commission and Yorkville shall jointly observe any adjustments that are made to the meters in case any adjustments shall be necessary.

D. Check Meters. Yorkville, at its option and its own expense, may install and operate a check meter to check each meter installed by the Commission, but the measurement of Lake Water for purposes of this Contract shall be solely by the Commission's meters, except in the cases hereinafter specifically provided to the contrary. All check meters shall be of standard make and shall be subject to inspection and examination by any employee or agent of the Commission at all reasonable times. The calibration and adjustment of check meters shall be made only by Yorkville, except during any period when a check meter may be used under the provisions hereunder for measuring the amount of Lake Water delivered to Yorkville, in which case the calibration and adjustment of such check meter shall be made by the Commission with like effects as if such check meter had been furnished and installed by the Commission.

E. Meter Malfunctions. If the Commission or Yorkville at any time observes a variation between a meter and a check meter or any evidence of meter malfunction, such party shall promptly notify the other party, and the Commission and Yorkville shall then cooperate to procure an immediate calibration test and such adjustment, replacement, or other work necessary to return such meter to accuracy. The party who discovers such variation or malfunction shall give the other party written notice not less than 48 hours prior to the time of any test of any meter (which tests shall be conducted during normal working hours) so that the other party may conveniently have a representative present. If such representative is not present after the required notification at the time set in such notice, calibration and adjustment may proceed in

the absence of said representative notwithstanding any other provision of this Subsection 5.E. If the percentage of inaccuracy of any meter is found to be in excess of two percent, registration thereof shall be corrected by agreement of the Commission and Yorkville based upon the best data available, for a period extending back to the time when such inaccuracy began if such time is ascertainable, or for a period extending back one-half of the time elapsed since the last date of calibration (but in no event further back than a period of six months) if such time is not ascertainable.

If for any reason any meter is out of service or out of repair so that the amount of Lake Water delivered cannot be ascertained or computed from the reading thereof, then the Lake Water delivered during the period such meter is out of service or out of repair shall be deemed to be the registration of the check meter if one has been installed and is registering accurately, or, in the event that no check meter has been installed or the check meter is registering inaccurately, shall be estimated:

(i) By correcting the error if the percentage of the error is ascertainable by calibration tests or mathematical calculations; or

(ii) If the error is not ascertainable by calibration tests or mathematical calculation, by estimating the quantity of delivery by considering deliveries during preceding periods under similar conditions when the meter or meters were registering accurately, adjusted for the addition of new customers to the Yorkville Unit System.

F. Removal of Metering Station and SCADA System Facilities. Within ninety (90) days after the termination of this Contract (absent a failure to renew), the Commission, at its own expense and in its discretion, may remove the metering station, including equipment, and the SCADA System antennas and appurtenant facilities from the property of Yorkville and release the perpetual easement therein. If the

Commission fails to remove such station, equipment, and facilities, as aforesaid, Yorkville may take title to such station, equipment, and facilities.

SECTION 6. UNIT OF MEASUREMENT.

The unit of measurement for Lake Water delivered hereunder shall be gallons of water, U.S. Standard Liquid Measure, and all measuring devices shall be so calibrated unless the Commission and Yorkville otherwise agree. Should it become necessary or desirable to use other units of measurement, the basis of conversion shall be that 7.48 gallons is equivalent to one cubic foot.

SECTION 7. PRICES AND TERMS OF PAYMENT.

A. Operation and Maintenance Costs Payment. Yorkville shall pay monthly to the Commission, at the time specified in Subsections 7.G and 7.M below, a share of the Commission's Operation and Maintenance Costs for each month, which shall be an amount equal to the then current price per 1,000 gallons for Operation and Maintenance Costs times the quantity of Lake Water divided by 1,000 delivered by the Waterworks System to the Yorkville Unit System for such month. At any time after the commencement of Lake Water delivery, no Lake Water is being supplied through the Waterworks System to any Contract Customer, Yorkville's share of monthly Operation and Maintenance Costs for the Yorkville Unit System shall be that proportion of those costs which the Yorkville Unit System's Water Allocation bears to the total Water Allocations of all of the Commission's customers required to make Operation and Maintenance Costs payments during the same period.

B. Fixed Costs Payment. Subject to the single limitation on its obligation to

pay Fixed Costs set forth in this Subsection 7.B, Yorkville shall pay monthly to the Commission, at the time specified in Subsections 7.G and 7.M below, one-twelfth of the Yorkville Unit System's share of Fixed Costs for each Fiscal Year. However, as of the date of this Contract, the Fixed Costs are \$0 per month. For the purposes of this Contract, the Yorkville Unit System's share of Fixed Costs for each Fiscal Year shall be that proportion of Fixed Costs which the Yorkville Unit System's Full Water Requirements for the two preceding calendar years prior to such Fiscal Year bears to the sum of the Full Water Requirements or Minimum Take or Pay Requirements, as applicable, of all of the Commission's Contract Customers for such two preceding calendar years who are not relieved from Fixed Costs payments pursuant to the terms of their contracts. Prior to the Commission's delivery of Lake Water to the Yorkville Unit System for two calendar years for other than start-up purposes pursuant to Subsection 10.1 of this Contract, the Yorkville Unit System's share of Fixed Costs shall be that portion of Fixed Costs which the Yorkville Unit System's Water Allocation bears to the total Water Allocations or the Full Water Requirements or Minimum Take or Pay Requirements, whichever is then applicable, of all of the Commission's Contract Customers who are not relieved from Fixed Costs payments pursuant to the terms of their contracts. Subject to the following single limitation, Yorkville's obligation to make all payments of Fixed Costs as required hereunder is unconditional and irrevocable, payable without setoff or counterclaim, and irrespective of whether Lake Water is ever furnished, made available, or delivered to the Yorkville Unit System, or whether the Waterworks System is completed, operable, or operating, and notwithstanding suspension, interruption, interference, reduction, or curtailment of the

supply of Lake Water. Yorkville's obligation to pay Fixed Costs hereunder is subject to the single limitation that, if for any period of time, and only during such period of time, the Commission is in fact supplying the Full Water Requirements or Minimum Take or Pay Requirements, as applicable, to Contract Customers of the Commission, other than Yorkville, whose Full Water Requirements and Minimum Take or Pay Requirements are more than 85 percent of the sum of the Full Water Requirements or Minimum Take or Pay Requirements, as applicable, of all Contract Customers of the Commission, and during such time the Commission is unable to supply any Lake Water to the Yorkville Unit System, then Yorkville shall have no obligation to pay Fixed Costs for the Yorkville Unit System. However, as of the date of this Contract, the Capital Recovery Cost Credit is \$0 because Fixed Costs are currently \$0.

C. Connection Facilities Cost Payment. Yorkville shall pay to the Commission its share of the Connection Facilities Cost in accordance with the WaterLink Communities Intergovernmental Cost Share Agreement, wherein Yorkville commits and agrees to pay 40.22% of the total Connection Facilities Cost. The Commission is not a party to the WaterLink Communities' Intergovernmental Cost-Share Agreement and has no responsibility or liability as to any true-up or adjusted accounting between the WaterLink Communities. Contemporaneously and pursuant to this Contract, Yorkville and the Commission shall enter into an WaterLink Project Escrow Intergovernmental Agreement with the United City of Yorkville (the "Escrow IGA") substantially in the form attached hereto as Exhibit G. In the event a line of credit issued by the Commission to Yorkville and any of the WaterLink Communities for Connection Facilities Costs the total line of credit amount provided to the

WaterLink Communities shall not exceed Twenty-one Million Dollars (\$21,000,000) (the "Commitment Amount"). Yorkville's obligation to make its share of the payment for the Connection Facilities Cost as required in and under the Escrow IGA is unconditional and irrevocable, and may be payable without setoff or counterclaim, and irrespective of whether Lake Water is ever furnished, made available, or delivered to Yorkville, or whether the Waterworks System is completed, operable, or operating, and notwithstanding suspension, interruption, interference, reduction, or curtailment of the supply of Lake Water.

D. Capital Cost Recovery Charge Payment. Yorkville shall pay monthly to the Commission, at the time specified in Subsections 7.G and 7.M below, an amount calculated by amortizing the Capital Cost Recovery Charge (less any Asset-in-Kind Amount), in equal monthly installments of principal and interest, at a rate per annum equal to the Earned Interest Rate determined for each Interest Period plus one percent, over the life of the Contract Customer Contract remaining as of the month in which Yorkville first becomes obligated to make such payment; provided, however, that such monthly installment may be adjusted by the Commission, on May 1 of each year thereafter, to ensure amortization of the then-current amount of the Capital Cost Recovery Charge (less any Asset-in-Kind Amount) remaining unpaid, as of such May 1, over the life of the Contract Customer Contract then remaining, and to reflect any change in the Earned Interest Rate, as of such May 1. The method of calculating the Capital Cost Recovery Charge is illustrated in Exhibit E attached to this Contract. Yorkville's obligation to make all Capital Cost Recovery Charge payments as required

hereunder is unconditional and irrevocable, payable without setoff or counterclaim, and irrespective of whether Lake Water is ever furnished, made available, or delivered to Yorkville, or whether the Waterworks System is completed, operable, or operating, and notwithstanding suspension, interruption, interference, reduction, or curtailment of the supply of Lake Water.

E. Underconsumption Costs Payment. If Yorkville is an Underconsumer at the Yorkville Unit System, then Yorkville shall pay, at the time specified in Subsections 7.G and 7.M below, its share of Underconsumption Costs as determined and assessed by the Commission after notification of such costs under the Water Supply Contract. In such event, Yorkville's share of Underconsumption Costs for the Yorkville Unit System for a year shall be equal to the ratio of its Underconsumption to the aggregate Underconsumption of all Underconsumers for such year.

F. Default Shares. If any of the Commission's Contract Customers shall default in any payment to the Commission, or any part of any payment, including default shares, Yorkville agrees to pay to the Commission a share of the amount so in default, which share shall be in the same proportion as the Yorkville Unit System's share of Aggregate Costs for the month prior to the month of the default bears to the sum of the shares of Aggregate Costs in that month of all of the Commission's Contract Customers not in default and obligated to make payments with respect to the amount so in default.

Subject to Subsection 7.M below, Yorkville's share of the amount so in default shall be due and payable 21 days after the Commission's written demand therefor. The

demand shall include the Commission's calculations of the amount due by Yorkville hereunder. If and when the defaulting customer makes a payment to the Commission of a defaulted amount or interest thereon for which Yorkville made a payment to the Commission under this Subsection 7.F, then the Commission will pay to Yorkville its proportionate share of such amount, including such interest.

G. Bills and Due Date. Except with respect to the payment of the Possible Shortfall required pursuant to Subsection 7.C above and the payment of default shares pursuant to Subsection 7.F above, the Commission shall notify Yorkville of the total amount due under this Contract for each month on or before the 10th day of the following month. Yorkville's costs for each month shall be due and payable and must be received at the offices of the Commission, on or before the 10th day of the month following the month of the Commission's notification or within 28 days after the date of notification, whichever is later.

H. Disputed Payments. If Yorkville desires to dispute any payment, or part thereof, due or reasonably claimed by the Commission to be due under this Contract, Yorkville shall nevertheless pay the full amount of any such payment when due and include with such payment written notification to the Commission that charges are disputed, the grounds for dispute, and the amount in dispute. No adjustment or relief on account of any disputed charges shall be made unless disputed charges are the subject of such notice within the time herein specified, or within a reasonable period from the time Yorkville knew or should have known of the facts giving rise to the dispute.

Upon receipt of a notification of dispute, representatives of the Commission shall meet promptly with representatives of Yorkville to resolve such dispute. No adjustment or relief on account of any disputed charges shall be made unless disputed charges are the subject of such notice within twenty-one (21) days of receipt by Yorkville of the bill, or within a reasonable period from the time Yorkville knew or should have known of the facts giving rise to the dispute.

If the Commission and Yorkville determine that all or a portion of the disputed payment should be refunded to Yorkville, then such sum shall be refunded with interest thereon at the rate established in Subsection 7.1 below from the date such disputed payment was made.

1. Interest on Overdue Payments. If Yorkville shall fail to make any payment required under this Contract, the Escrow IGA, or the Capital Cost Recovery Charge IGA to the United City of Yorkville on or before its due date, Yorkville shall be in default, and interest on the amount of such payment shall accrue to the extent permitted by law, and be compounded on a monthly basis, during the period of non-payment at the higher of:

- (i) the weighted average effective interest rate on all series of Bonds of the Commission any of which are then outstanding plus two percent; or
- (ii) the Prime Rate plus five percent.

Such interest shall accrue from the date such payment becomes due until paid in full with interest as herein specified. If such payment is not made by Yorkville within 30 days after the date such payment becomes due, then the Commission, at its option

and in its discretion, may reduce or discontinue delivery of Lake Water to the Yorkville Unit System until the amount due the Commission is paid in full with interest as herein specified. The Commission shall give notice to Yorkville not less than 20 days prior to the event of its intention to reduce or discontinue delivery of Lake Water in accordance with this Subsection 7.1 and shall provide Yorkville an opportunity for a hearing before the Commission prior to any reduction or discontinuance. If the Commission reduces or discontinues the delivery of Lake Water under such circumstances, Yorkville shall nevertheless continue to be liable to pay all charges provided for herein as if the Yorkville Unit System were receiving its Full Water Requirements from the Commission. The rights specified in this Subsection 7.1 shall be in addition to all other rights and remedies available to the Commission under this Contract, at law, or in equity for breach of any of the provisions of this Contract.

J. Security Deposit. If Yorkville is at any time in default on any payment due under this Contract, the Escrow IGA, or the Capital Cost Recovery Charge IGA, and the default is not cured within 30 days after the due date of the defaulted payment, then the Commission, at its option and in its discretion, may require Yorkville, as a further obligation under this Contract, to deposit in a separate account in the Commission's name a sum of money as security for the payment of Yorkville's obligations hereunder of a reasonable amount determined by the Commission. Yorkville's compliance with the Commission's demand for such a security deposit shall be a condition precedent to the curing of such Yorkville default and the restoration of the Lake Water service to the Yorkville Unit System if such Lake Water service has been reduced or discontinued

by reason of such default. The security deposit or any part thereof may be applied, at the Commission's option and in its discretion, to any subsequent default by Yorkville in any payments due under this Contract, the Escrow IGA or the Capital Cost Recovery Charge IGA. If so applied, Yorkville shall provide funds within 10 days to restore the security deposit to the amount required by the Commission. At the earliest of the end of the term of this Contract, or a term of two years after the curing of the most recent default by Yorkville, or such earlier time that the Commission at its option and in its discretion may determine, any security deposit shall be returned to Yorkville if Yorkville has performed all its obligations under this Contract, the Escrow IGA or the Capital Cost Recovery Charge IGA. Yorkville shall not be entitled to receive any interest on any security deposit.

K. Prepayments. Subject to the limitations of this paragraph, Yorkville may (i) at any time, and from time to time, before Yorkville first becomes obligated to make payments of Operation and Maintenance Costs pursuant to Subsection 7.M below, and (ii) no more frequently than once in any given year thereafter, at any time during the month of December, prepay, in whole or in part, the Connection Facilities Cost, the Capital Cost Recovery Charge Amount due, or other amount previously agreed to, pursuant to this Contract, without premium or penalty, upon at least one business day's irrevocable notice to the Commission, specifying the date and amount of prepayment. If such notice is given, Yorkville shall make such prepayment and the payment amount specified in such notice shall be due and payable on the date specified therein. The proceeds of any such prepayment shall be applied by the Commission first, to the

payment of accrued and unpaid interest, if any, on the Connection Facilities Cost accruing after the date specified in Subsection 7.M below; second, to the payment of the unpaid principal balance of the Connection Facilities Cost; third, to the payment of accrued and unpaid interest, if any, on the Capital Cost Recovery Charge Amount accruing after the date specified in Subsection 7.M below; and fourth, to the payment of the unpaid principal balance of the Capital Cost Recovery Charge Amount; provided, however, that Yorkville shall not be entitled to make any such prepayment pursuant to this paragraph if Yorkville's Base Rate during the Fiscal Year next following the date of such payment would be, as estimated by the Commission, less than the Average Contract Customer Rate Per 1,000 Gallons. For purposes of calculating Yorkville's Base Rate, any such prepayment shall be deemed to have been paid effective as of the 30th day of April next following the date of such payment or the 30th day of April next following the month in which Yorkville first becomes obligated to make such Connection Facilities Cost payments and Capital Cost Recovery Charge Amount payments, whichever is later. Yorkville shall not be entitled to, nor receive any credit for, interest on any such prepayment.

Notwithstanding anything to the contrary contained herein, in the event the Yorkville Unit System has not been constructed, installed, and completed, to a point where it is capable of serving its intended function at the time Yorkville first becomes obligated to make payments of Operation and Maintenance Costs pursuant to Subsection 7.M below, then the Commission may, in its sole and absolute discretion, declare the principal amount of the Connection Facilities Cost remaining unpaid, in whole or in

part, the principal amount of the Capital Cost Recovery Charge remaining unpaid, in whole or in part, or both of such remaining unpaid costs, in whole or in part, due and payable within 30 days following the date of such declaration, together with accrued and unpaid interest as herein specified on such declared due amounts to the date paid, unless the Commission shall have exercised its right to terminate this Contract pursuant to Subsection 20.C of this Contract. The rights specified in this paragraph shall be in addition to all other rights and remedies available to the Commission under this Contract, at law, or in equity for breach of any of the provisions of this Contract.

L. Enforcement of Provisions Hereof by Other Customers. Yorkville acknowledges that its obligation to make payments pursuant to the terms of this Section 7 is of benefit to the Commission's Contract Customers, Bondholders, and any Trustee. Accordingly, Yorkville agrees that, in addition to the Commission, Bondholders, a Trustee or other parties allowed by law are entitled to enforce the provisions of this Contract. Further, any three or more of the Commission's Contract Customers acting together may enforce the provisions of this Section 7, but only if the Commission has not acted to enforce such provisions within 90 days after any failure by Yorkville to make a payment hereunder.

M. Beginning of Obligation to Pay. Notwithstanding any other provision of this Contract, the obligation to make any and all payments under this Contract, except only payments of Operation and Maintenance Costs pursuant to Subsection 7.A above and payment of any Possible Shortfall required pursuant to Subsection 7.C above, shall begin on the Commission's first regular billing cycle after the earlier to occur of (i) the

first delivery of Lake Water to the Yorkville Unit System or any portion thereof or (ii) 12 months following completion of construction of the Commission Connection Facilities, other than the SCADA System facilities, to the point where they are capable of serving their intended function or would be capable of serving their intended function except for the fact that the Yorkville Unit System Connection Facilities are not complete. The obligation to make payments of Operation and Maintenance Costs pursuant to Subsection 7.A above shall begin on the Commission's first regular billing cycle after the earlier to occur of (i) the first delivery of Lake Water to the Yorkville Unit System or any portion thereof or (ii) completion of construction of the Commission Connection Facilities, other than the SCADA System Facilities, to the point where they are capable of serving their intended function or would be capable of serving their intended function except for the fact that the Yorkville Unit System Connection Facilities are not complete. At any time prior to the first delivery of Lake Water to the Yorkville Unit System when Yorkville is obligated to make payments pursuant to this Subsection 7.M, such payments shall be based on the Full Water Requirements of the Yorkville Unit System.

SECTION 8. SPECIAL CONDITIONS AND COVENANTS.

A. Construction of the Commission Connection Facilities; No Delay Damages; Supply of Lake Water. The Commission will make a diligent effort to have the Commission Connection Facilities completed to the Points of Delivery so as to furnish Lake Water to the Yorkville Unit System by the date specified in Subsection 10.H of this Contract, but the Commission does not in any way guaranty delivery by such date.

Yorkville acknowledges and agrees that the Commission shall not be liable to Yorkville for any damages occasioned by or in any way related to delay in the delivery of Lake Water to the Yorkville Unit System, and all payments from Yorkville provided for under this Contract shall remain due and payable in accordance with the terms of this Contract notwithstanding any such delay.

After Lake Water is first tendered for delivery to the Yorkville Unit System at the Points of Delivery for other than start-up purposes pursuant to Subsection 10.1 of this Contract, the Commission, subject to the other terms and conditions of this Contract, shall use its best efforts to continually hold itself ready, willing, and able to supply Lake Water to the Yorkville Unit System at such Points of Delivery. The Commission also shall use its best efforts, consistent with its prior obligations and legal obligations to its customers and consistent with the fair and equitable treatment of all of its Contract Customers, to supply the Yorkville Unit System with such additional amounts of Lake Water as from time to time may be allocated to the Yorkville Unit System over and above the Yorkville Unit System's present Water Allocation; provided, however, that the Commission does not in any way guaranty a supply of such additional amounts.

B. Lake Water Only; Costs. Except with the prior approval of Yorkville, the Commission shall not deliver any water to the Yorkville Unit System other than Lake Water. Except for Lake Water supplied for start-up purposes pursuant to Subsection 10.1 of this Contract, costs for Lake Water charged to Yorkville by the Commission pursuant to this Contract shall include only the costs set forth in Section 7 of this Contract.

C. Title to Lake Water. Title to all Lake Water supplied hereunder shall remain in the Commission to the Points of Delivery and thereupon shall pass to Yorkville.

D. Emergency Supply. Subject to the terms, conditions, and limitations set forth in Subsection 9.N of this Contract, Yorkville may contract for a temporary supply of water in case of an emergency from any unit of local government or any other entity. Yorkville shall notify the Commission and shall promptly provide the Commission with copies of all such contracts.

E. Covenants to Be Set Out in Bond Ordinance. Yorkville acknowledges the existence, and its understanding of the provisions, of certain Bond Ordinances pursuant to which the Commission has previously issued its Bonds. Yorkville further acknowledges and agrees that said Bond Ordinances grant to Bondholders certain rights to enforce certain duties of the Commission and its customers, including those with respect to the making of rates and charges and the collection of revenues, and that such Bondholder rights may be included in any subsequent Bond Ordinances.

F. Payments Hereunder are an Operational Expense of the Yorkville Unit System. Yorkville agrees that, to the fullest extent permitted by law or contract, all payments to be made by Yorkville pursuant to this Contract shall constitute operating expenses of the Yorkville Unit System as to any and all revenue bonds of Yorkville which are supported in whole or in part by a pledge of the revenues of the Yorkville Unit System, with the effect that Yorkville's obligation to make payments from its water revenues under this Contract has priority over its obligation to make payments

of the principal and of the premium, if any, and interest on any such bonds which are or will be supported in whole or in part by a pledge of any Yorkville Unit System revenues. Yorkville shall make all budgetary, emergency, and other provisions and appropriations necessary to provide for and authorize the prompt payment to the Commission of all rates and charges under this Contract. The obligations of Yorkville under this Contract are further payable from all other accounts of the Yorkville Unit System in which there are lawful available funds. In any revenue bond or indenture hereafter issued by Yorkville, the priority of lien established pursuant to this Contract shall be expressly provided and set forth in said bond ordinances or resolutions. Notwithstanding the foregoing, however, Yorkville's obligations under the IEPA Loans referenced in Subsection 9.D to be secured in whole or in part by a pledge of Yorkville Unit System revenues to the IEPA shall have priority of lien over Yorkville's obligation to make payment from its water revenues under this Contract.

SECTION 9. ADDITIONAL YORKVILLE COVENANTS.

A. Maintenance of Corporate Existence. Yorkville agrees that during the term of this Contract it will maintain its municipal corporate existence, it will continue to be a municipal corporation in good standing in the State of Illinois, it will not dissolve or otherwise dispose of all or substantially all of the assets of the Yorkville Unit System.

B. Maintenance and Operation of Yorkville Unit System. Yorkville shall own and maintain the Yorkville Unit System and the Yorkville Unit System Connection Facilities, and all improvements and extensions of the Yorkville Unit System and the

Yorkville Unit System Connection Facilities, in good repair and working order, will operate the Yorkville Unit System and the Yorkville Unit System Connection Facilities efficiently, and will punctually perform all duties with respect to the Yorkville Unit System and the Yorkville Unit System Connection Facilities as may be required by this Contract, and by the Constitution and laws of the State of Illinois and all other applicable laws. In the event of any deterioration, injury, damage, or other loss to the Yorkville Unit System or the Yorkville Unit System Connection Facilities affecting Yorkville's ability to deliver water to any of Yorkville's customers, Yorkville shall promptly restore the Yorkville Unit System or the Yorkville Unit System Connection Facilities and their capacity to so deliver water.

C. Rate Covenant. Yorkville shall take all necessary actions to establish, maintain, revise as necessary, and collect rates and charges for customers of the Yorkville Unit System as shall be required from time to time to produce revenues at least sufficient:

(i) To pay all amounts due under this Contract, the Escrow IGA, the Capital Cost Recovery Charge IGA and the IEPA Loans referenced herein, and to pay all other costs of operation and maintenance of the Yorkville Unit System and the Yorkville Unit System Connection Facilities; and

(ii) To provide an adequate depreciation fund for the Yorkville Unit System and the Yorkville Unit System Connection Facilities; and

(iii) To make all deposits in all funds and accounts required by the terms of resolutions or ordinances authorizing any obligation of Yorkville payable from the revenues of the Yorkville Unit System; and

(iv) To pay the principal of and the premium, if any, and interest on all

obligations of Yorkville payable from the revenues of the Yorkville Unit System including, but not limited to, its obligations under the Escrow IGA, the Capital Cost Recovery Charge IGA, and to repay the IEPA Loans referenced in Subsection 9.D.

D. Future Subordination of Obligations. Any ordinance, resolution, motion, or other action of Yorkville which authorizes the issuance after the date of this Contract of any obligation of Yorkville to be paid from the revenues of the Yorkville Unit System will expressly provide that revenues of said System may be used to pay principal of, and the premium, if any, and the interest on such obligations only to the extent that those revenues exceed the amounts required to pay the operation and maintenance expenses of said System including, expressly, all amounts payable from time to time under this Contract, except for any present or future ordinance, resolution, motion or other action of Yorkville which authorizes, or has authorized, it to borrow funds from and enter a loan agreement with the Illinois Environmental Protection Agency (the "IEPA Loans") which may provide for the collection, segregation, distribution and/or pledge of revenues of the Yorkville Unit System which shall be the only obligation with preference of priority over Yorkville's obligation to the Commission hereunder.

E. General Covenant to Operate Properly. From time to time, Yorkville shall take all steps reasonably necessary so that the Yorkville Unit System and the Yorkville Unit System Connection Facilities may at all times be operated in accordance with industry standards.

F. Accounting and Audit. Yorkville shall make and keep proper books and accounts (separate and apart from all other records and accounts of Yorkville) in which

complete entries shall be made of all transactions relating to the Yorkville Unit System, and, within 180 days after the close of each of its fiscal years occurring during the term of this Contract, Yorkville shall cause the books and accounts of the Yorkville Unit System to be audited annually by independent certified public accountants, showing the receipts and disbursements on account of the Yorkville Unit System.

G. Maintain Ownership of Yorkville Unit System. Yorkville shall construct to completion and thereafter continue to own and possess the Yorkville Unit System and, within the exercise of reasonable business judgment and in a manner so as not to cause a default hereunder, shall dispose of property which is part of said System only to the extent that the Commission consents in writing, which consent shall not be unreasonably withheld. This subsection G does not prohibit Yorkville from selling specific equipment that it considers surplus and that is no longer needed or utilized to operate the Yorkville Unit System.

H. Insurance. Yorkville shall carry insurance or maintain self-insurance with respect to the Yorkville Unit System and the Yorkville Unit System Connection Facilities of the kinds and in the amounts that are customarily carried or maintained by parties operating similar properties, including, without limiting the generality of the foregoing, fire and other casualty and liability insurance or protection. All moneys received for loss under the insurance policies or on deposit as self-insurance reserves shall be used in making good the loss or damage in respect of which they were paid, whether by repairing the property damaged or replacing the property destroyed, and provision for making good such loss or damage or replacing the property destroyed

shall be made within a reasonable time from date of loss. The proceeds derived from any and all policies or available from self-insurance reserves for public liability losses shall be used in paying or reimbursing any accounts from which payments for settlements, judgments, or expenses were advanced.

I. Continue to Serve. Yorkville shall use its best efforts to continue serving all customers of the Yorkville Unit System within its territorial limits that are intended to be served by the Yorkville Unit System as of the date of this Contract.

J. Maintain Water Allocation. Yorkville shall use its best efforts to obtain or retain, from time to time, a Water Allocation for the Yorkville Unit System at least equal to, but not in excess of two times, the Yorkville Unit System's Full Water Requirements from time to time.

K. Release and Indemnification. To the fullest extent permitted by law, Yorkville hereby releases the Commission from, agrees that the Commission shall not be liable for, and agrees to indemnify and hold the Commission harmless from: (1) any liabilities for any loss or damage to property or any injury to, or death of, any person that may be occasioned by or related to any cause whatsoever pertaining to the construction, installation, removal, relocation, replacement, extension, improvement, maintenance, or operation of the Yorkville Unit System or the Connection Facilities or (2) any liabilities, losses, or damages, or claims therefor, arising out of the failure, or claimed failure, of Yorkville to comply with its covenants or obligations contained in this Contract, including, in each such case, any attorneys' fees. Yorkville agrees to indemnify and hold the Commission harmless to the fullest extent permitted by law from any losses, costs, charges, expenses (including attorneys' fees), judgments, and

liabilities incurred by the Commission in connection with any action, suit, or proceeding instituted or threatened by any third party in connection with this Contract. If any such claim is asserted, the Commission shall give prompt notice to Yorkville and Yorkville, if requested by the Commission, shall assume the defense thereof, it being understood, however, that Yorkville shall not settle or consent to the settlement of any such claim without the written consent of the Commission.

L. Combining or Separating System Accounts. Yorkville shall not combine its waterworks system with its sewerage system or separate its combined waterworks and sewerage system into separate systems unless:

(i) Yorkville shall have provided the Commission with written evidence, satisfactory to the Commission, that the proposed combination or separation will not materially or adversely affect Yorkville's ability to comply with all of the terms, conditions, and covenants of this Contract; and

(ii) The Commission shall have approved such combination or separation in writing.

M. Rate of Withdrawal. Yorkville will take Lake Water at the most uniform and continuous rate of withdrawal practical.

N. Emergency Interconnections. No emergency interconnection between the Yorkville Unit System and a water distribution system owned and operated by another Contract Customer ("Emergency Interconnection") shall be constructed, operated, or maintained except in accordance with the following terms, conditions, and limitations:

(i) The other Contract Customer and Yorkville shall submit to the Commission, for its review and approval, at least 60 days prior to the construction of the Emergency Interconnection or, if the Emergency Interconnection was constructed prior to the execution of this Contract, within 60 days following the execution of this Contract, a report detailing

the exact location of the Emergency Interconnection, the manner in which the Emergency Interconnection has been and will be operated and maintained, and the terms of any written or oral agreement for the operation and maintenance of the Emergency Interconnection. Such report shall include as-built drawings of the Emergency Interconnection and exact duplicates of any written agreement for the operation and maintenance of the Emergency Interconnection. The Emergency Interconnection shall not be operated unless and until the Commission shall have approved such report and the Commission shall have received and approved the written agreements required pursuant to clauses (ix) and (xii) of this Subsection 9.N. No approval of such report shall be withheld unless the Emergency Interconnection, or any agreement for the operation and maintenance of the Emergency Interconnection, violate the Contract Customer Contract, this Contract, the Water Supply Contract, or applicable laws or regulations, or pose a threat to the Commission or its Waterworks System.

(ii) The Emergency Interconnection shall be utilized only under emergency conditions unless otherwise approved, in writing, by the Commission. An emergency condition shall be defined to mean the inability to provide average day flow demands to regular, non-emergency supply customers during a limited period of time due to conditions beyond the control of the party requesting Lake Water. An emergency condition shall not mean any limitation imposed by the Commission on the supply of Lake Water to the other Contract Customer or Yorkville specifically related to the other Contract Customer or Yorkville pursuant to Section 3 of this Contract or any similar provision of any other water purchase and sale contract, as the case may be, and the Emergency Interconnection shall not be utilized to circumvent the provisions of any agreement approved by the Commission for the Alternate Delivery of Lake Water.

(iii) The Emergency Interconnection shall be maintained in such a manner as at no time to place or threaten to place the Commission or its Waterworks System in jeopardy of failing to meet the terms of the Contract Customer Contract, this Contract, the Water Supply Contract, or the regulations of any agency or governmental authority having jurisdiction over the of a public water supply.

(iv) The party experiencing the emergency condition shall give telephonic notice to the Commission and to the other party of the emergency condition, the expected duration of the emergency condition, and the amount of Lake Water needed, prior to the operation of the Emergency Interconnection. The Emergency Interconnection shall not

be operated unless and until the party experiencing the emergency condition shall have given said notice to the Commission.

(v) The party receiving Lake Water through the Emergency Interconnection shall provide daily telephonic notice to the Commission and the party delivering Lake Water for so long as the emergency deliveries continue, and shall provide telephonic notice to the Commission before final shut-off of the emergency flow of Lake Water through the Emergency Interconnection for each such emergency condition.

(vi) The other Contract Customer and Yorkville shall keep a joint record of the amount of Lake Water delivered through the Emergency Interconnection, a copy of which shall be provided to the Commission within five days following termination of the use of the Emergency Interconnection for each such emergency condition and, in any case, every five days where the Emergency Interconnection is continuous for more five days.

(vii) The amount of Lake Water delivered to the other Contract Customer's water distribution system or to the Yorkville Unit System through the Emergency Interconnection, as the case may be, shall be paid to the Commission directly by the party receiving Lake Water through the Emergency Interconnection at the rates applicable pursuant to, and in accordance with, that party's water purchase and sale contract with the Commission. In case of service curtailment, the other Contract Customer's flow of water through the Emergency Interconnection shall be considered as a portion of the other Contract Customer's allocation from the Commission. In case of service curtailment, Yorkville's flow of water through the Emergency Interconnection shall be considered as a portion of Yorkville's allocation from the Commission.

(viii) The Commission shall have the right to inspect the Emergency Interconnection, and its operation and maintenance. The Commission shall have the right to install seals or such other devices as the Commission, in its sole and absolute discretion, determines are necessary to determine the operation of the Emergency Interconnection, and all equipment required to be installed to allow the installation of the seals or such other devices shall be installed at Yorkville's sole cost and expense.

(ix) The Commission shall bear no responsibility for, and the other Contract Customer and Yorkville shall, in writing, release the Commission from, and agree, to the fullest extent permitted by law, that the Commission shall not be liable for, and agree to indemnify and hold the Commission harmless from, any claims, damages, liabilities, and

litigation that may be occasioned by, connected with, or in any way related to the construction, operation, and maintenance of the Emergency Interconnection. The other Contract Customer and Yorkville shall agree, in writing, to pay all fees, costs, and expenses, including legal and administrative fees, costs, and expenses, incurred by the Commission in defending itself with regard to any and all of the matters mentioned in this Subsection 9.N.

(x) The operation and maintenance of the Emergency Interconnection shall comply in all other respects with the Water Commission Act of 1985, the Contract Customer Contract, this Contract and the Water Supply Contract and the requirements of the Commission thereunder.

(xi) Notwithstanding anything to the contrary contained in any written or oral agreement for the operation and maintenance of the Emergency Interconnection, the Emergency Interconnection shall be operated and maintained only in accordance with this Subsection 9.N and such additional or other terms, conditions, and limitations as the Commission shall impose pursuant to any policy established by the Commission with respect to emergency interconnections. No such agreement shall be amended, modified, or otherwise changed except upon the prior written approval of the Commission.

(xii) The Commission reserves the right to order all use of the Emergency Interconnection to be discontinued, and the other Contract Customer and Yorkville shall agree, in writing, to discontinue such use, at any time the terms, conditions, and limitations of this Subsection 9.N and any such additional or other terms, conditions and limitations imposed by the Commission pursuant to any policy established by the Commission with respect to emergency interconnections are not satisfied.

No emergency interconnection between the Yorkville Unit System and a water distribution system owned and operated by any other person, firm, or organization shall be constructed, operated, or maintained except upon the prior written approval of Commission.

SECTION 10. SCHEDULE FOR COMPLETION OF VARIOUS FACILITIES.

A. Plans and Specifications for Yorkville Unit System Connection Facilities.

Yorkville shall prepare and submit to the Commission for its review and approval,

complete detailed plans, specifications, and construction contract documents for the Yorkville Unit System Connection Facilities not later than 20 weeks after the effective date of this Contract. The Commission shall provide its comments and revisions to Yorkville within 4 weeks after receipt of such documents. Yorkville shall incorporate all required changes to such documents within 4 weeks after receipt of the Commission's comments and revisions.

B. IEPA and Other Approvals for Yorkville Unit System Connection Facilities. Yorkville shall, within one week after receipt of the Commission's comments and revisions pursuant to Subsection 10.A above, submit such finally revised documents for approval and permitting to the Illinois Environmental Protection Agency (the "IEPA") and every other federal, state, or local governmental body having jurisdiction over any element of the Yorkville Unit System Connection Facilities, and shall diligently pursue each such approval and permit until it is secured.

C. Commencement of Construction of Yorkville Unit System Connection Facilities. Yorkville shall cause construction of the Yorkville Unit System Connection Facilities to be commenced within 52 weeks after the effective date of this Contract or 11 weeks after receipt of the last approval from any governmental body required as a condition precedent to construction of the Yorkville Unit System Connection Facilities, whichever is later. Yorkville shall cause construction to be completed within 104 weeks after commencement.

D. Intentionally Omitted.

E. Intentionally Omitted.

F. Intentionally Omitted.

G. Transfer of Property Rights. Yorkville shall grant to the Commission all necessary easements for the Commission metering station and other facilities to be constructed pursuant to Subsection 5.A of this Contract within 26 weeks after the effective date of this Contract. Yorkville shall, immediately upon execution of this Contract, commence all actions necessary to acquire all property rights not already owned by it necessary to fulfill the requirements of Subsection 5.A of this Contract and this Subsection 10.G.

H. Commencement of Construction of Commission Connection Facilities. The Commission shall cause design of the Commission Connection Facilities to be commenced within 8 weeks after receipt from Yorkville of the preliminary plans and specifications for the Yorkville Unit System Connection Facilities satisfactory to the Commission or upon acquisition of all rights of way and other property by Yorkville acquired for the installation of the Commission Connection Facilities, whichever is later. The Commission shall cause construction to be completed within 104 weeks after receipt of the last approval from any governmental body required as a condition precedent to construction of the Commission Connection Facilities or May 1, 2028, whichever is later. Yorkville acknowledges and agrees, however, that the Commission may, in the exercise of its sole and absolute discretion, accelerate commencement of the design and construction of the Commission Connection Facilities, or completion of construction thereof, without in any way affecting the obligations of Yorkville under this Contract, including without limitation Yorkville's payment obligations.

I. Delivery of Water for Start-Up Purposes. The Commission shall use its best efforts, consistent with its prior obligations and legal obligations to its customers

and consistent with the fair and equitable treatment of all of its Contract Customers, to supply Yorkville with Lake Water for pressure testing, disinfecting, and flushing the Yorkville Unit System, the Yorkville Unit System Connection Facilities, and the required water storage facilities prior to completion of construction if (i) construction of the Yorkville Unit System, the Yorkville Unit System Connection Facilities, and the required water storage facilities is proceeding in the regular course to completion; (ii) the construction of the Commission Connection Facilities has been completed, other than the SCADA System facilities, to the point where the Commission Connection facilities are capable of serving their intended function or would be capable of serving their intended function except for the fact that the Yorkville Unit System or the Yorkville Unit System Connection Facilities are not complete; (iii) such Lake Water is utilized by Yorkville solely for purposes of pressure testing, disinfecting, and flushing the Yorkville Unit System, the Yorkville Unit System Connection Facilities, or the required water storage facilities; and (iv) Yorkville pays to the Commission, at the time specified in Subsection 7.H of this Contract, an amount equal to the then current price per 1,000 gallons for Operation and Maintenance Costs times the amount of water, stated in thousands of gallons, actually received from the Commission for such purposes until such time as Yorkville first becomes obligated to make payments of Operation and Maintenance Costs pursuant to Subsections 7.A and 7.M of this Contract.

J. Illustrative Schedule of Events. An “Illustrative Schedule of Events” depicting, on the basis of assumptions concerning the length of time necessary to secure various governmental approvals, the sequence of work pursuant to this Section

10 is attached to this Contract as Exhibit F. In the event of any conflict or inconsistency between the provisions of Exhibit F and the provisions of this Section 10, the provisions of this Section 10 shall control.

SECTION 11. ASSIGNABILITY.

Yorkville shall not assign or transfer this Contract or any rights or interests herein without the advance written consent of the Commission.

The right to receive all payments that are required to be made by Yorkville to the Commission in accordance with the provisions of this Contract may be assigned by the Commission to any Trustee as provided in any Bond Ordinances/Resolutions to secure the payment of the principal of and the premium, if any, and interest on the Bonds as those amounts come due, subject to the application of those payments as may be provided in any Bond Ordinances/Resolutions. Yorkville, upon notice of assignment to any such Trustee, shall make all payments directly to such Trustee. Further, the rights of the Commission to enforce the provisions of this Contract may be assigned to any such Trustee and, in such event, such Trustee shall have the right to enforce this Contract at law or in equity with or without the further consent or participation of the Commission. The Commission also may retain the right to enforce this Contract.

SECTION 12. FORCE MAJEURE.

If, by reason of a force majeure event, either party to this Contract shall be rendered unable wholly or in part to carry out its obligation under this Contract, then if such party shall give notice and full particulars of such force majeure event in writing to the

other party within seven (7) days after occurrence of the event or cause relied on, the obligation of the party giving such notice, so far as it is affected by such force majeure event, shall be suspended during the continuance of the inability then claimed, but for no longer period, and any such party shall endeavor to remove or overcome such inability with all reasonable dispatch. The term "force majeure event" as employed herein shall mean acts of God; strikes, lockouts, or other industrial disturbances; acts of a public enemy; orders of any kind of the Government of the United States, of the State of Illinois, or of any civil or military authority; insurrections; riots; epidemics; pandemics; landslides; lightning; earthquakes; fires; hurricanes; storms; floods; washouts; droughts; arrests; restraints of government and people; civil disturbances; explosions, breakage, or accidents to machinery, pipelines, canals, or tunnels; partial or entire failure of water supply; and inability on the part of the Commission to deliver Lake Water hereunder, or of Yorkville to receive Lake Water hereunder, on account of any other causes not reasonably within the control or ability to cure of the party claiming such inability. The settlement of strikes and lockouts shall be entirely within the discretion of the party having the difficulty and the above requirement that any force majeure event shall be remedied with all reasonable dispatch shall not require the settlement of strikes and lockouts by acceding to the demands of the opposing party or parties when such settlement is unfavorable to it in the judgment of the party having the difficulty. No force majeure event which renders either of the parties unable to perform under this Contract shall relieve Yorkville of its obligation to make payments to the Commission as required under Section 7 of this Contract and such payments

shall continue as if the Yorkville Unit System were receiving its Full Water Requirements from the Commission.

SECTION 13. COMMISSION DEFAULTS.

Failure by the Commission to deliver Lake Water to Yorkville as required by this Contract or failure of the Commission to perform any other obligation under this Contract, and the continuation of that failure to perform for 30 days after written notice from Yorkville to the Commission of such failure, shall be a default of the Commission under this Contract, unless any such failure is excused pursuant to Section 12 of this Contract. If the Commission defaults under this Contract, then Yorkville may bring any action against the Commission allowed by law. No Commission default shall relieve Yorkville of its obligation to make payments to the Commission as required under Section 7 of this Contract and such payments shall continue as if the Yorkville Unit System were receiving its Full Water Requirements from the Commission.

SECTION 14. YORKVILLE OBLIGATION UNCONDITIONAL.

Yorkville shall have no right to terminate, cancel, or rescind this Contract; no right to withhold from the Commission or any Trustee who is an assignee of the Commission pursuant to Section 11 of this Contract payments due or to become due under this Contract; no right to recover from the Commission or any such Trustee amounts previously paid under this Contract unless paid in error or contrary to the provisions of this Contract or law; no right of reduction or set-off against the amounts due or to become due under this Contract to the Commission or any such Trustee; and no lien on any amounts in any fund established by the Commission or such Trustee for any

reason or on account of the existence or occurrence of any event, condition, or contingency, whether foreseen or unforeseen or foreseeable or unforeseeable by Yorkville or the Commission or any other person, including by way of illustration and not limitation by reason of the fact that the Waterworks System in whole or in part is not completed, operable, or operating; or the output of the Waterworks System in whole or in part is suspended, interrupted, interfered with, reduced, or curtailed; or any party to the Water Supply Contract does not perform in whole or in part thereunder; or the Water Allocation of any of the Commission's Contract Customers is modified or terminated or any such Contract Customer does not perform in whole or in part any agreement or instrument, it being the intent hereof that Yorkville shall be absolutely and unconditionally obligated to make all payments under this Contract. The Commission may issue Bonds in specific reliance on the limitations set forth in this Section 14 with respect to the rights of Yorkville.

SECTION 15. COOPERATION IN CONSTRUCTION; EASEMENTS.

Yorkville shall cooperate with the Commission in the construction and acquisition of the Waterworks System. Yorkville is responsible for acquiring all necessary real property and easements within the City to build the Connection Facilities and shall transfer that insured real property and insured easements to the Commission upon acquisition. Additionally, Yorkville, within 30 days after Commission's request therefor, shall grant without charge to the Commission all required construction easements and all insured easements necessary for portions of the Waterworks System to be located on Yorkville's property, free and clear of all liens, claims, encumbrances,

and restrictions unless otherwise approved by the Commission in writing, provided the Commission agrees to restore the easement property in a reasonable manner after construction. Yorkville shall grant the Commission all access to its property necessary to construct and install the Commission Connection Facilities and all other equipment and appurtenant devices to the Point of Delivery.

SECTION 16. COOPERATION IN ISSUANCE OF BONDS.

Yorkville shall cooperate with the Commission in the issuance of Bonds. In connection therewith, Yorkville shall comply with all reasonable requests of the Commission and shall upon request do as follows:

- A. Make available general and financial information about itself in accordance with GAAP; and
- B. Consent to publication and distribution of its financial information; and
- C. Certify that general and financial information about it is accurate, does not contain an untrue statement of a material fact, and does not omit to state a material fact necessary in order to make the statements in that information, in light of the circumstances under which they were made, not misleading; and
- D. Make available certified copies of official proceedings; and
- E. Provide reasonable certifications to be used in a transcript of closing documents; and
- F. Provide and pay for reasonably requested opinions of counsel of its choice as to the validity of its actions taken with respect to, and the binding effect of, this Contract, title to the Yorkville Unit System, pending or threatened litigation which could materially affect its performance hereunder, and other reasonably related opinions.

SECTION 17. REGULATORY BODIES.

The Commission and Yorkville through this Contract seeks to exercise and maintain

all sovereign rights granted to it under and through the Constitution and laws of the State of Illinois. This Contract shall be subject to all valid rules, regulations, and laws applicable hereto passed or promulgated by the United States of America, the State of Illinois, any governmental body or agency having lawful jurisdiction, and any authorized representative or agent of any of them; provided, however, that this clause shall not be construed as waiving the right of either party to challenge the validity of such rule, regulation, or law on any basis, including the impairment of this Contract.

SECTION 18. OTHER WATER SUPPLIERS.

Notwithstanding any of the provisions of this Contract, the Commission is not prohibited by this Contract from entering into cooperative arrangements with other suppliers or users of Lake Water to provide Lake Water to each other to meet each other's water needs, provided that these arrangements do not interfere, except in emergencies, with the delivery of Lake Water to the Yorkville Unit System.

SECTION 19. NOTICES; EVIDENCE OF ACTIONS; WAIVER.

A. Notices. All notices or communications provided for herein shall be in writing and shall be delivered either in person or by United States mail, by certified mail with return receipt requested, postage prepaid, and addressed as follows:

To the Commission:
DuPage Water Commission
600 East Butterfield Road
Elmhurst, IL 60126
Attention: General Manager

To Yorkville:

United City of Yorkville
800 Game Farm Road
Yorkville IL 60560
Attention: City Administrator

Copy to:

Kathleen Field Orr
City Attorney
Kathleen Field Orr & Associates
2024 Hickory Road, Suite 305
Yorkville, IL 60560

until and unless other addresses or addressees are specified by notice given in accordance herewith.

B. Evidence of Actions. Any action hereunder to be taken by the Commission or Yorkville may be evidenced by copy of official proceedings (including pertinent minutes, motions, resolutions, or ordinances, as applicable) duly certified by the Clerk of the Commission or the City Clerk of Yorkville.

All notices, demands, requests, consents, approvals, and other instruments required or permitted to be made or given by Yorkville pursuant to this Contract shall be in writing, signed by a duly authorized officer, agent, or attorney of Yorkville.

C. Waiver. No course of dealing or failure of the Commission or Yorkville to enforce strictly any term, right, or condition of this Contract shall be construed as a waiver of such term, right, or condition. No express waiver of any term, right, or condition of this Contract shall operate as a waiver of any other term, right, or condition.

D. Partial Invalidity. If a term or provision of this Contract or the application thereof to any person or circumstances shall, to any extent, be invalid or unenforceable,

the remainder of this Contract, or the application of such term or provision to persons or circumstances other than those as to which it is held invalid or unenforceable, shall not be affected thereby, and each such term and provision of this Contract shall be valid and be enforced to the fullest extent permitted by law.

SECTION 20. EFFECTIVE DATE; TERMINATION; PAYMENT OF INTERIM COSTS; TERM.

A. Effective Date. Except for the provisions of Section 10 of this Contract relating to the commencement of certain work following execution of this Contract and except for the provisions of Section 20.C of this Contract relating to the payment of certain costs, as to which provisions this Contract shall be effective immediately after authorization and execution by both parties hereto, this Contract shall be effective upon authorization and execution by both parties hereto and issuance by the State of Illinois Department of Natural Resources, Office of Water Resources, of a Water Allocation permit to Yorkville for each discrete and non-contiguous service area served by the Yorkville Unit System.

B. Commission Right to Terminate. If the Yorkville Unit System has not been constructed, installed, and completed to a point where it is capable of serving its intended function at the time Yorkville first becomes obligated to make payments of Operation and Maintenance Costs pursuant to Subsection 7.M of this Contract, the Commission may, in its sole and absolute discretion, terminate this Contract, in which event the Commission shall give notice to Yorkville not less than 20 days in advance of its intention to terminate this Contract and shall provide Yorkville an opportunity for a hearing before the Commission prior to the effective date of such termination

and, upon the concurrence of a majority of the Commissioners of the Commission following the conclusion of such hearing, this Contract shall be of no further force or effect except for the provisions of Subsection 20.D below, as to which provisions this Contract shall remain in full force and effect.

C. Payment of Interim Costs. Whether or not the Yorkville Unit System is ever completed, operable, or operating, Yorkville shall pay to the Commission all attorneys', engineering, and administrative fees, costs, and expenses incurred by the Commission for any work related to, or participation in, any regulatory proceeding which shall be required or requested of the Commission by the Illinois Department of Natural Resources, Office of Water Resources, or by Yorkville as a result of, or occasioned by, this Contract and, further, shall pay to the Commission all attorneys', engineering, and administrative fees, costs, and expenses incurred by the Commission in connection with the negotiation, preparation, consideration, and review of this Contract and in implementing the terms of this Contract, including without limitation the costs of the design and construction of the Commission Connection Facilities. If the Yorkville Unit System has not been completed as and when required by Subsection 20.B above and the Commission elects, in its sole and absolute discretion, to terminate this Contract pursuant to Subsection 20.B above, then Yorkville's payment hereunder shall be due and payable immediately after receipt by it of an invoice from the Commission detailing such costs, after deducting therefrom the amount or amounts of any prepayments made pursuant to Subsection 7.K of this Contract. If the amount or amounts of any such prepayments exceed Yorkville's payment obligation hereunder,

the Commission shall refund the difference to Yorkville. If either (i) the Yorkville Unit System is completed as and when required by Subsection 20.B above or (ii) if not completed, the Commission does not elect to terminate this Contract, then such costs shall be treated as part of the Connection Facilities Cost provided in Subsection 7.C of this Contract.

D. Term. Unless this Contract is sooner terminated by the Commission pursuant to Subsection 20.B above, this Contract shall continue in force and effect until February 24, 2064.

SECTION 21. GOVERNING LAW AND VENUE.

This Contract shall be construed exclusively under the applicable laws, but not the conflicts of laws rules, of the State of Illinois. The parties agree that venue for any litigation arising out of this Contract shall only be proper in the Eighteenth Judicial Circuit Court, DuPage County, Illinois and waive any right, whether statutory or otherwise, to venue in any other jurisdiction.

SECTION 22. MUNICIPAL BOUNDARIES.

Not later than 365 days after the execution of this Contract, Yorkville shall provide the Commission with: (i) a current list of all parcels within Yorkville's corporate limits, identified by Property Index Number and common address, (ii) a correct, complete legal description of the entire boundary of the municipality, and (iii) an aerial photograph depicting the entire boundary of the Yorkville municipal limits. Yorkville shall update the information in this Section 22 within 60 days of any changes in its municipal boundaries.

SECTION 23. MODIFICATIONS OR AMENDMENTS.

This Contract shall not be modified or amended in any way except in writing approved by both parties hereto. No such modification or amendment shall materially impair or adversely affect the ability or obligation of Yorkville to make payments to the Commission to meet the Commission's obligations under the Water Supply Contract, the Contract Customer Contract, and the Bond Ordinances/Resolutions.

SECTION 24. EXHIBITS INCORPORATED.

Exhibits A, B-1, B-2, C, D, E, F, and G to this Contract are hereby fully incorporated into this Contract as substantive provisions of this Contract.

SECTION 25. EXECUTION IN COUNTERPARTS.

This Contract shall be executed in two counterparts, each of which shall be deemed to be an original, and each of which shall constitute but one and the same instrument.

[SIGNATURE PAGE FOLLOWS]

IN WITNESS WHEREOF, the parties hereto have caused their respective corporate names to be subscribed hereto and their respective corporate seals to be affixed hereto and attested by their duly authorized officers, all on the date set opposite their respective corporate names.

Date: 10/3/24

VILLAGE OF OSWEGO

By: 
Ryan Kauffman - President

ATTEST:

Tina Touchette - Village Clerk

Date: _____

DUPAGE WATER COMMISSION

By: _____
James F. Zay - Chairman

ATTEST:

Danna M. Mundall - Clerk

EXHIBIT A
YORKVILLE UNIT SYSTEM

Village of Yorkville
Water Purchase and Sale Contract

EXHIBIT A - YORKVILLE UNIT SYSTEM

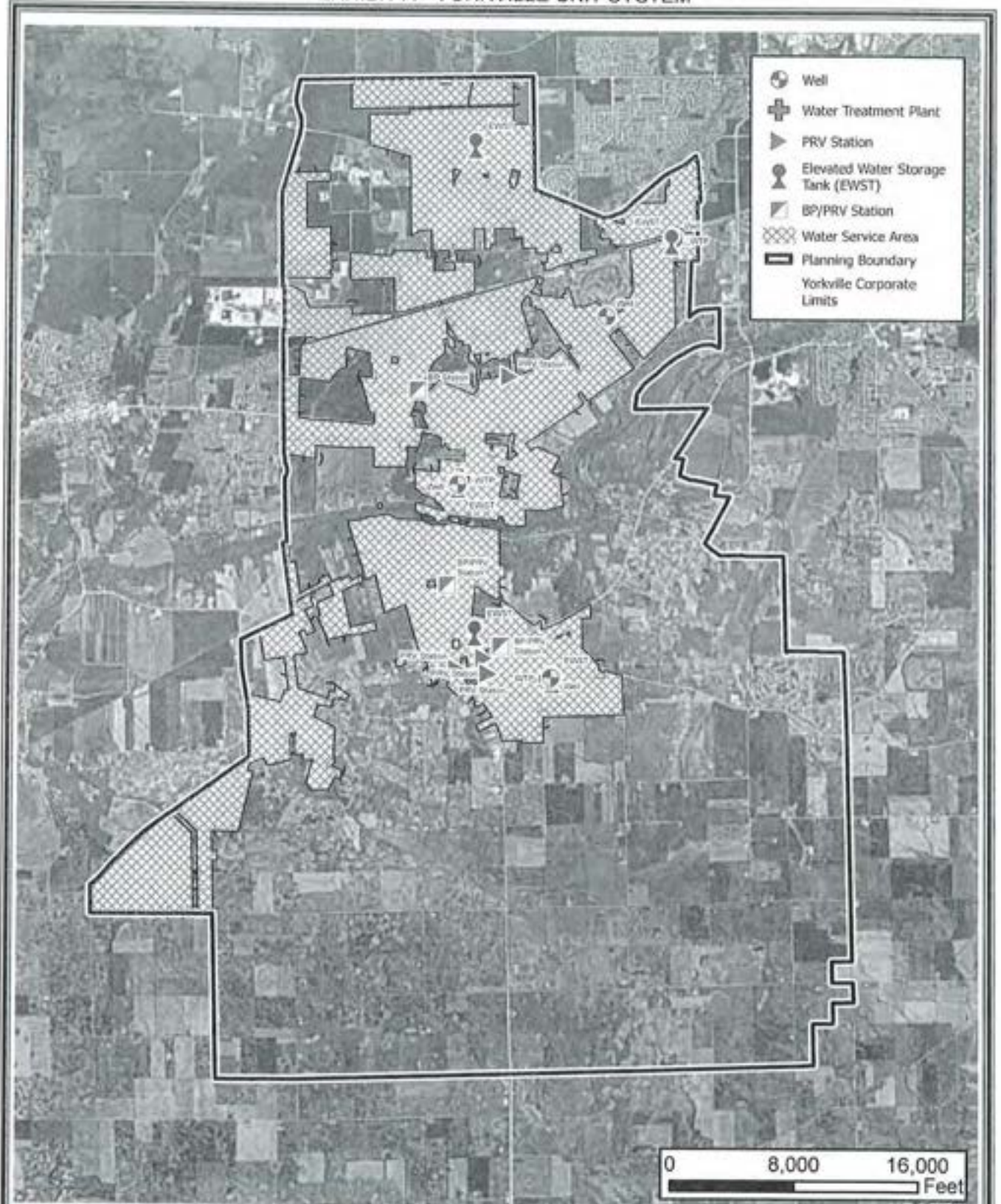

- Well
- ⊕ Water Treatment Plant
- ▶ PRV Station
- ⊕ Elevated Water Storage Tank (EWST)
- ▣ BP/PRV Station
- ▨ Water Service Area
- ▭ Planning Boundary
- ▭ Yorkville Corporate Limits

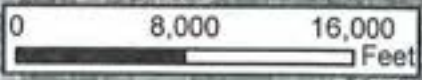

Engineering Enterprises, Inc.
 52 Wheeler Road
 Sugar Grove, Illinois 60554
 (630) 466-6700
 www.eeweb.com



United City of Yorkville
 651 Prairie Pointe Dr.
 Yorkville, IL 60560
 630-553-4350

DATE	SEPTEMBER 2014
PROJECT NO.	Y02014
REV.	001
DATE	SEP 2014
BY	PLANNING DEPARTMENT
FOR	PLANNING DEPARTMENT

**UNITED CITY OF YORKVILLE
 WATER SERVICE AREA**



EXHIBIT B-1
YORKVILLE UNIT SYSTEM CONNECTION FACILITIES

United City of Yorkville
Water Purchase and Sale Contract

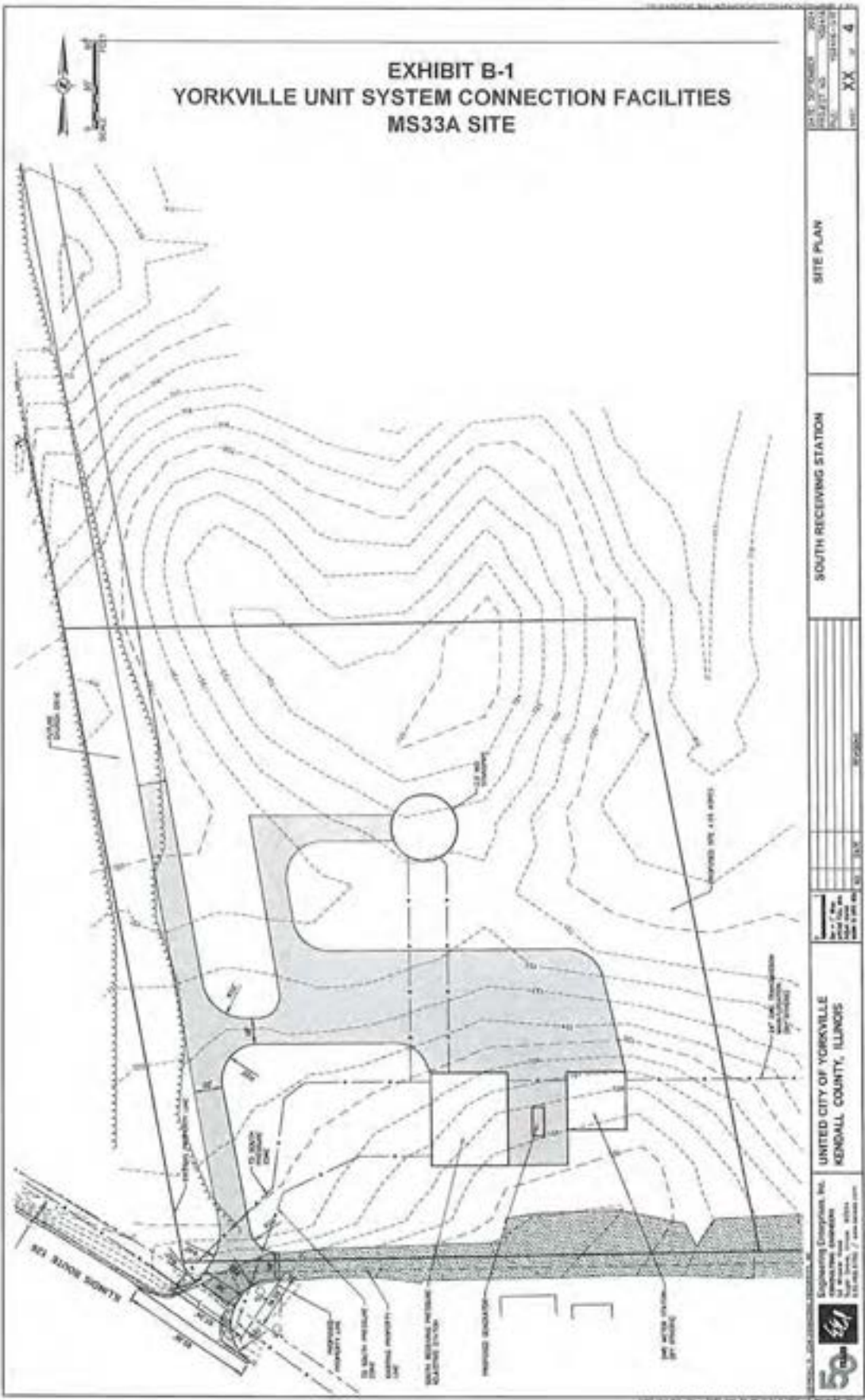

EXHIBIT B-1

WATER DELIVERY DATA

DU PAGE WATER COMMISSION

Date: September 18, 2024 (data provided by Yorkville consultant working with DWC Consultant)

CUSTOMER NAME United City of Yorkville

DELIVERY POINT (DWC NODE No.) MS 33A

TYPE OF CUSTOMER PAS FACILITY REQUIRED Rate Control Type D

LOCATION AT Illinois Route 71 and Wing Rd., Yorkville IL

DWC DESIGN MINIMUM HYDRAULIC GRADE* (USGS DATUM) 824

CUSTOMER'S SYSTEM OVERFLOW ELEV. AND/OR REQUIRED HEAD** 920

CUSTOMER'S STORAGE FACILITY 1.5 MG Elevated

HYDRAULIC DATA

	Flow Rate @ Customer's Facility MGD	DWC Hydraulic Grade 10 ft. Downstream of DWC Meter Station USGS Datum
2032 Avg. Day	<u>1.00 MGD</u>	<u>876</u>
<u>2032</u> Max. Day	<u>1.70 MGD</u>	<u>885</u>
2050 Avg. Day	<u>2.42 MGD</u>	<u>824</u>
<u>2050</u> Max. Day	<u>4.11 MGD</u>	<u>875</u>
<u>2050</u> Peak***	<u>7.26 MGD</u>	

* DWC design minimum hydraulic grade will fluctuate approx. \pm 10 feet depending upon Commission's elevated storage water elevation.

** It is customer's responsibility to verify the system overflow elevation or required head.

*** 3 x 2050 average day flow or 1500 GPM minimum.

EXHIBIT B-1

WATER DELIVERY DATA

DU PAGE WATER COMMISSION

Date: September 18, 2024 (data provided by Yorkville consultant working with DWC Consultant)

CUSTOMER NAME United City of Yorkville

DELIVERY POINT (DWC NODE No.) MS 33B

TYPE OF CUSTOMER PAS FACILITY REQUIRED Rate Control Type C

LOCATION AT 3099 Lehman Crossing, Yorkville IL

DWC DESIGN MINIMUM HYDRAULIC GRADE* (USGS DATUM) 836

CUSTOMER'S SYSTEM OVERFLOW ELEV. AND/OR REQUIRED HEAD** 810

CUSTOMER'S STORAGE FACILITY 1.5 MG Elevated

HYDRAULIC DATA

	Flow Rate @ Customer's Facility MGD	DWC Hydraulic Grade 10 ft. Downstream of DWC Meter Station USGS Datum
2032 Avg. Day	<u>1.50 MGD</u>	<u>878</u>
2032 Max. Day	<u>2.55 MGD</u>	<u>897</u>
2050 Avg. Day	<u>3.64 MGD</u>	<u>836</u>
2050 Max. Day	<u>6.19 MGD</u>	<u>882</u>
2050 Peak***	<u>10.92 MGD</u>	

* DWC design minimum hydraulic grade will fluctuate approx. \pm 10 feet depending upon Commission's elevated storage water elevation.

** It is customer's responsibility to verify the system overflow elevation or required head.

*** 3 x 2050 average day flow or 1500 GPM minimum.

EXHIBIT B-1

PRELIMINARY PLANS FOR THE YORKVILLE
UNIT SYSTEM CONNECTION FACILITIES

MINIMUM REQUIREMENTS FOR PRESSURE ADJUSTING (PA) STATIONS
AND SCHEMATICS

1. Rate Controllers shall be adjusted and the water distribution shall otherwise be operated to take a normally uniform flow rate from the DWC system. The maximum hourly rate should in no case be greater than 1.7 times the average annual hourly rate based on the current Lake Michigan water allocation for the PA station. The adequacy of customer system storage and proper operation of storage facilities to assure uniform take-off is the customer's responsibility.
2. Designs shall provide for the appropriate fluctuation of customer storage facility levels to assure uniform take-off. Elevated storage tanks shall be fluctuated appropriately during sub freezing conditions.
3. Emergency bypass lines, flow rate controllers and system isolation check valves shall be required in all designs.
4. Altitude valves or other appropriate means for preventing elevated and ground storage tank overflows are recommended if such provisions do not already exist in the customer's system.
5. Surge relief facilities for protection of both the customer and DWC facilities shall be required.
6. the type and design of the PA station will be dependent upon:
 - a. The difference between, (i) the minimum DWC system pressure (hydraulic grade) 10 feet downstream of the DWC Metering Station (MS) and, (ii) the customer's elevated tank overflow or system pressure.
 - b. Whether ground storage will be used to receive water at the PA station.

In general, the recommended design types for the various receiving facility designs and the differential between the minimum DWC system grade (at the point of delivery) and the customer system elevated tank overflows or system pressure are as follows:

<u>Design Type</u>	<u>Head (DWC – Customer)</u>
Pressure Reducing (Type A & B)	> / = 28 feet
Rate Control (Type C)	< 28 feet & > / = 0 feet
Pressure Increasing (Type D)	< 0 feet

EXHIBIT B-1

PRELIMINARY PLANS FOR THE YORKVILLE
UNIT SYSTEM CONNECTION FACILITIES

7. Where pumping stations are required (Type D), each station shall be equipped with three (3) pumping units of equal size. Each unit shall have rated capacity of approximately equal to the average day, year 2020 flow, at the station. Two (2) pumping units shall have a combined capacity to provide maximum day, year 2020 flow (1.7 times average day year 2020 flow). The third unit is for standby. A fourth space is shown on the pumping station (Type D) schematic for an additional pumping unit at the customer's option.
8. The facility requirements indicated are for illustrative purposes showing general guidelines and various design functions to be provided. Each station shall be designed and proper equipment shall be selected to meet local and specific conditions.
9. Emergency conditions may permit three (3) times average day flow at the PA based on the year 2020 Lake Michigan Water Allocation or 1500 GPM, whichever is greater.
10. The Commission will only provide a chlorine residual meeting State and Federal Standards at the point of delivery. Additional chlorination facilities, if required, shall be provided by the customer at the customer's expense.

EXHIBIT B-1 YORKVILLE UNIT SYSTEM CONNECTION FACILITIES

PRESSURE REDUCING STATION - TYPE A

- 1) HOURLY FLOWS SHALL BE UNIFORM THROUGHOUT EACH DAY* AND RATE NOT EXCEED 1.7 X AVERAGE DAY FLOW AT THE STATION BASED ON CURRENT YEAR LAKE MICHIGAN WATER ALLOCATION.
- 2) PRESSURE REDUCING STATION IS REQUIRED IF THE COMMISSION'S SYSTEM DESIGN PRESSURE** EXCEEDS THE DESIRED CUSTOMER'S SYSTEM PRESSURE BY TWELVE (12) P.S.I. (28 FT.) OR MORE.
- 3) PRESSURE REDUCING STATION TYPE A - CONNECTIONS TO GROUND RESERVOIR AND SYSTEM.
 - A. PRESSURE REDUCING AND CHECK VALVE, AND RATE CONTROLLER (MAXIMUM FLOW LIMIT CONTROL) ARE REQUIRED.
 - B. PRESSURE RELIEF FOR BOTH DWC AND CUSTOMER'S SYSTEM IS REQUIRED.
 - C. EMERGENCY BYPASS IS REQUIRED.
 - D. ALTITUDE VALVE WITH PRESSURE SUSTAINING FUNCTION AND BYPASS (CUSTOMER'S RESPONSIBILITY) ARE RECOMMENDED FOR GROUND RESERVOIR CONNECTION. PROPER DAILY USE OF THE RESERVOIR IS REQUIRED.
 - E. CHLORINATION SYSTEM IS OPTIONAL (CUSTOMER'S RESPONSIBILITY).
- 4) EMERGENCY CONDITIONS MAY PERMIT 3X AVERAGE DAY FLOW AT THE STATION BASED ON 2020 LAKE MICHIGAN WATER ALLOCATION OR 1500 GPM WHICHEVER IS LARGER.
- 5) STANDBY PRESSURE REDUCING AND CHECK VALVE ARE REQUIRED.
- 6) THE FACILITY REQUIREMENTS INDICATED ARE FOR ILLUSTRATIVE PURPOSE SHOWING GENERAL GUIDELINES AND VARIOUS DESIGN FUNCTIONS TO BE PROVIDED. EACH STATION SHALL BE DESIGNED, AND PROPER EQUIPMENT SHALL BE SELECTED TO MEET LOCAL CONDITIONS AND SITE SPECIFICS.

*ACCOMPLISHED BY SETTING RATE CONTROLLER IN ACCORDANCE WITH THE CUSTOMER DEMAND.

**DESIGN PRESSURE WILL FLUCTUATE APPROXIMATELY \pm 10 FEET DEPENDING UPON COMMISSION'S ELEVATED STORAGE WATER ELEVATION.

SCHEMATIC OF PRESSURE REDUCING STATION TYPE A

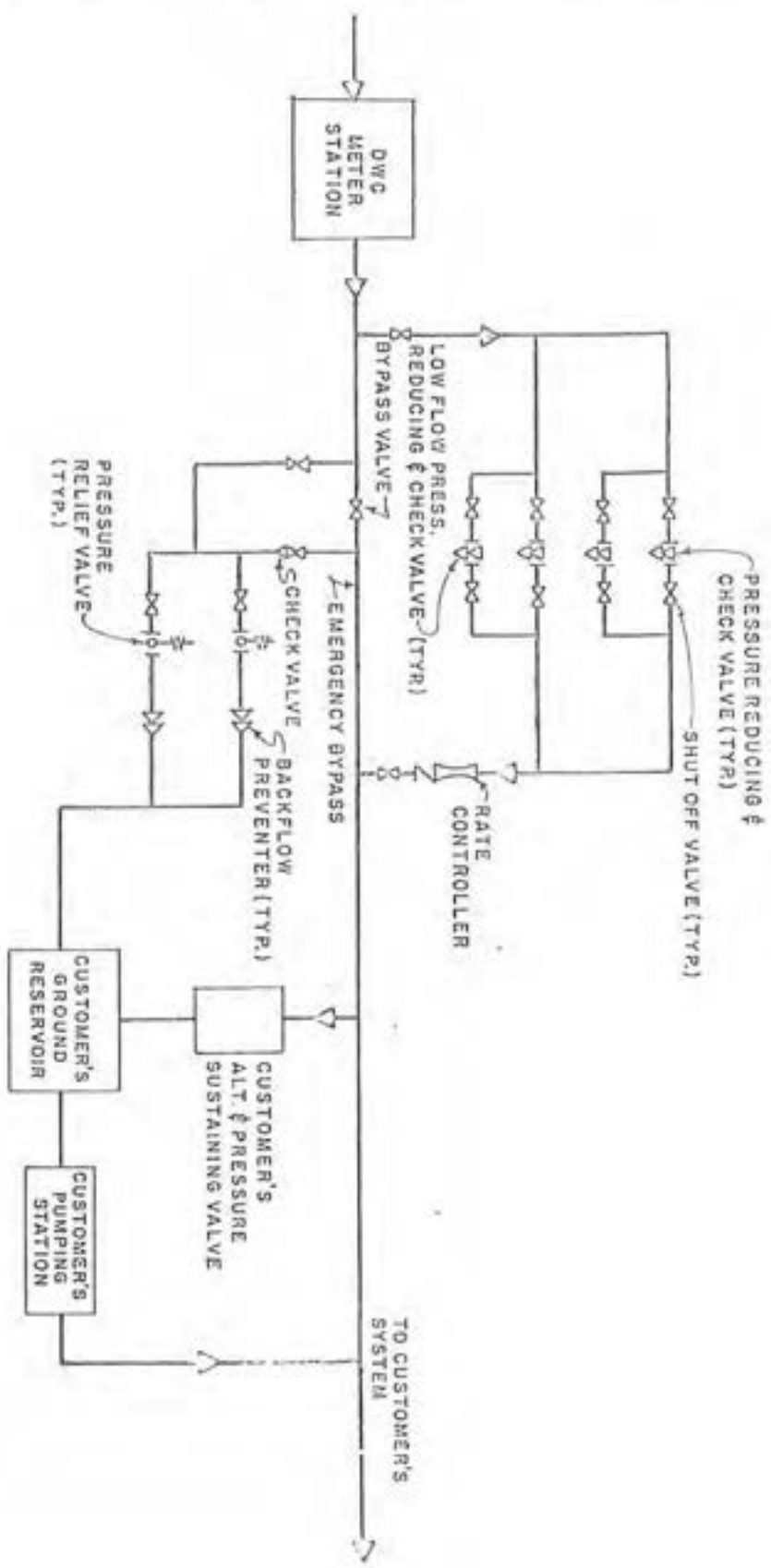

EXHIBIT B-1 YORKVILLE UNIT SYSTEM CONNECTION FACILITIES

DU PAGE WATER COMMISSION
DATE:

ALVORD, BURDICK & HOWSON
ENGINEERS CHICAGO

EXHIBIT B-1 YORKVILLE UNIT SYSTEM CONNECTION FACILITIES

PRESSURE REDUCING STATION - TYPE B

- 1) HOURLY FLOWS SHALL BE UNIFORM THROUGHOUT EACH DAY* AND RATE NOT EXCEED 1.7 X AVERAGE DAY FLOW AT THE STATION BASED ON CURRENT YEAR LAKE MICHIGAN WATER ALLOCATION.
- 2) PRESSURE REDUCING STATION IS REQUIRED IF THE COMMISSION'S SYSTEM DESIGN PRESSURE** EXCEEDS THE DESIRED CUSTOMER'S SYSTEM PRESSURE BY TWELVE (12) P.S.I. (28 FT.) OR MORE.
- 3) PRESSURE REDUCING STATION TYPE B - CONNECTIONS TO ELEVATED TANK AND SYSTEM.
 - A. PRESSURE REDUCING AND CHECK VALVE, AND RATE CONTROLLER (MAXIMUM FLOW LIMIT CONTROL) ARE REQUIRED.
 - B. PRESSURE RELIEF FOR BOTH DWC AND CUSTOMER'S SYSTEM IS REQUIRED.
 - C. EMERGENCY BYPASS IS REQUIRED.
 - D. ALTITUDE VALVE WITH BYPASS (CUSTOMER'S RESPONSIBILITY) IS RECOMMENDED FOR ELEVATED TANK CONNECTION. PROPER DAILY USE OF THE TANK IS REQUIRED.
 - E. CHLORINATION SYSTEM IS OPTIONAL (CUSTOMER'S RESPONSIBILITY).
- 4) EMERGENCY CONDITIONS MAY PERMIT 3X AVERAGE DAY FLOW AT THE STATION BASED ON 2020 LAKE MICHIGAN WATER ALLOCATION OR 1500 GPM WHICHEVER IS LARGER.
- 5) STANDBY PRESSURE REDUCING AND CHECK VALVE ARE REQUIRED.
- 6) THE FACILITY REQUIREMENTS INDICATED ARE FOR ILLUSTRATIVE PURPOSE SHOWING GENERAL GUIDELINES AND VARIOUS DESIGN FUNCTIONS TO BE PROVIDED. EACH STATION SHALL BE DESIGNED, AND PROPER EQUIPMENT SHALL BE SELECTED TO MEET LOCAL CONDITIONS AND SITE SPECIFICS.

*ACCOMPLISHED BY SETTING RATE CONTROLLER IN ACCORDANCE WITH THE CUSTOMER DEMAND.

**DESIGN PRESSURE WILL FLUCTUATE APPROXIMATELY + 10 FEET DEPENDING UPON COMMISSION'S ELEVATED STORAGE WATER ELEVATION.

SCHEMATIC OF PRESSURE REDUCING STATION: TYPE B

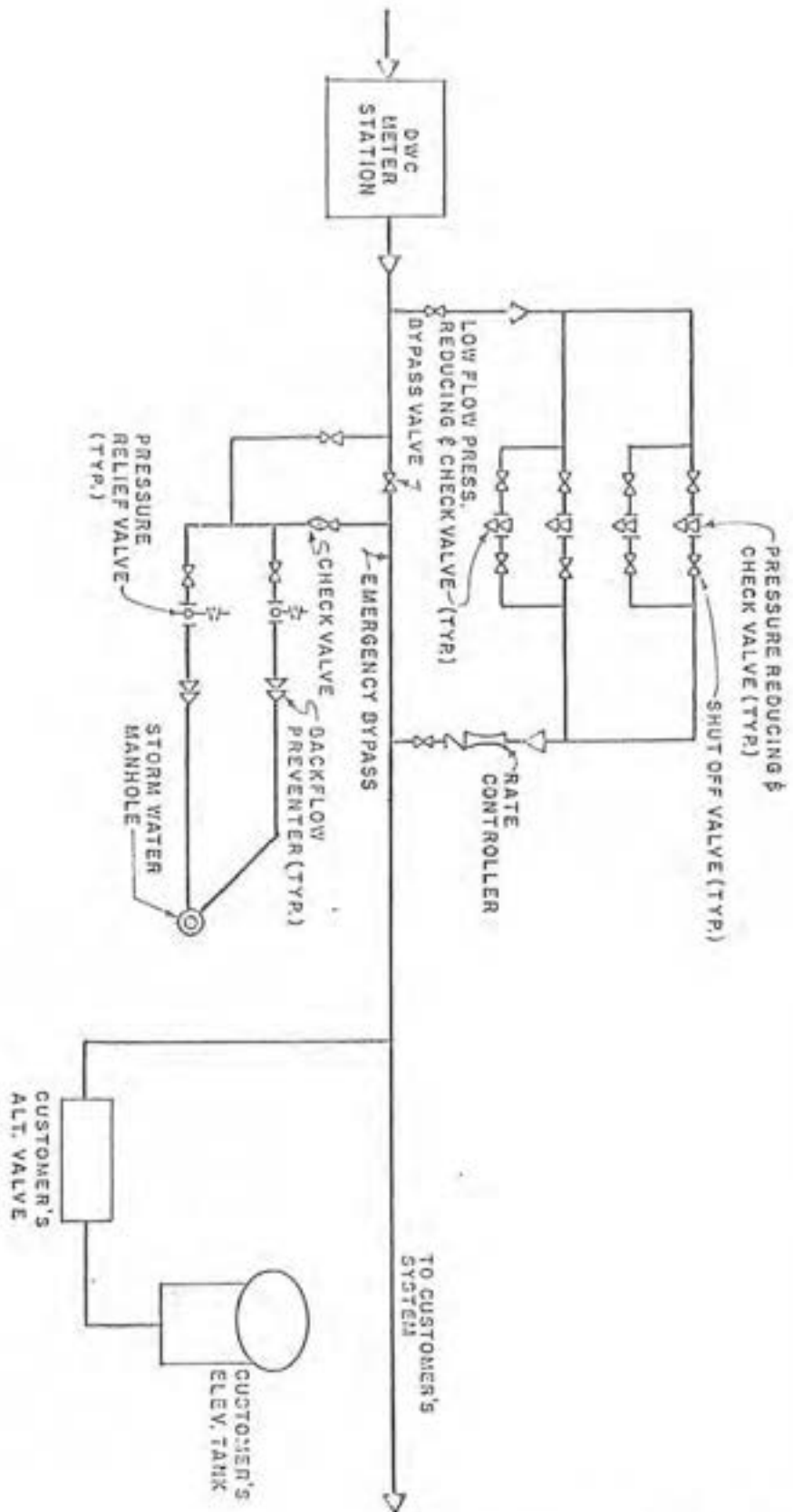

DUPAGE WATER COMMISSION
DATE:

ALVORD, BURDICK & HOVSON
ENGINEERS
CHICAGO

EXHIBIT B-1 YORKVILLE UNIT SYSTEM CONNECTION FACILITIES

PRESSURE REDUCING STATION - TYPE C

- 1) HOURLY FLOWS SHALL BE UNIFORM THROUGHOUT EACH DAY* AND RATE NOT EXCEED 1.7 X AVERAGE DAY FLOW AT THE STATION BASED ON CURRENT YEAR LAKE MICHIGAN WATER ALLOCATION.
- 2) PRESSURE REDUCING STATION IS REQUIRED IF THE COMMISSION'S SYSTEM DESIGN PRESSURE** EXCEEDS THE DESIRED CUSTOMER'S SYSTEM PRESSURE BY TWELVE (12) P.S.I. (28 FT.) OR MORE.
- 3) PRESSURE REDUCING STATION TYPE C - DIRECT CONNECTIONS TO DISTRIBUTION SYSTEM.
 - A. ALL DIRECT CONNECTIONS FROM DUPAGE WATER COMMISSION FEEDER MAIN TO DISTRIBUTION SYSTEM SHALL REQUIRED DWC APPROVAL.
 - B. MAXIMUM HOUR TAKE-OFF RATE SHALL BE REGULATED TO COMPLY WITH ITEM 1) REQUIREMENTS. ADEQUACY OF STORAGE CAPACITY IS CUSTOMER'S RESPONSIBILITY.
 - C. PRESSURE REDUCING AND CHECK VALVE, AND RATE CONTROLLER (MAXIMUM FLOW LIMIT CONTROL) ARE REQUIRED.
 - D. PRESSURE RELIEF FOR BOTH DWC AND CUSTOMER'S SYSTEM IS REQUIRED.
 - E. EMERGENCY BYPASS IS REQUIRED.
 - F. ALTITUDE VALVE WITH BYPASS (AND PRESSURE SUSTAINING FUNCTION FOR GROUND STORAGE) IS RECOMMENDED FOR STORAGE CONNECTION (CUSTOMER'S RESPONSIBILITY). PROPER DAILY USE OF THE STORAGE IS REQUIRED.
 - G. CHLORINATION SYSTEM IS OPTIONAL (CUSTOMER'S RESPONSIBILITY).
- 4) EMERGENCY CONDITIONS MAY PERMIT 3X AVERAGE DAY FLOW AT THE STATION BASED ON 2020 LAKE MICHIGAN WATER ALLOCATION OR 1500 GPM WHICHEVER IS LARGER.
- 5) STANDBY PRESSURE REDUCING AND CHECK VALVE ARE REQUIRED.
- 6) THE FACILITY REQUIREMENTS INDICATED ARE FOR ILLUSTRATIVE PURPOSE SHOWING GENERAL GUIDELINES AND VARIOUS DESIGN FUNCTIONS TO BE PROVIDED. EACH STATION SHALL BE DESIGNED, AND PROPER EQUIPMENT SHALL BE SELECTED TO MEET LOCAL CONDITIONS AND SITE SPECIFICS.

*ACCOMPLISHED BY SETTING RATE CONTROLLER IN ACCORDANCE WITH THE CUSTOMER DEMAND.

**DESIGN PRESSURE WILL FLUCTUATE APPROXIMATELY + 10 FEET DEPENDING UPON COMMISSION'S ELEVATED STORAGE WATER ELEVATION.

SCHEMATIC OF PRESSURE REDUCING STATION TYPE C

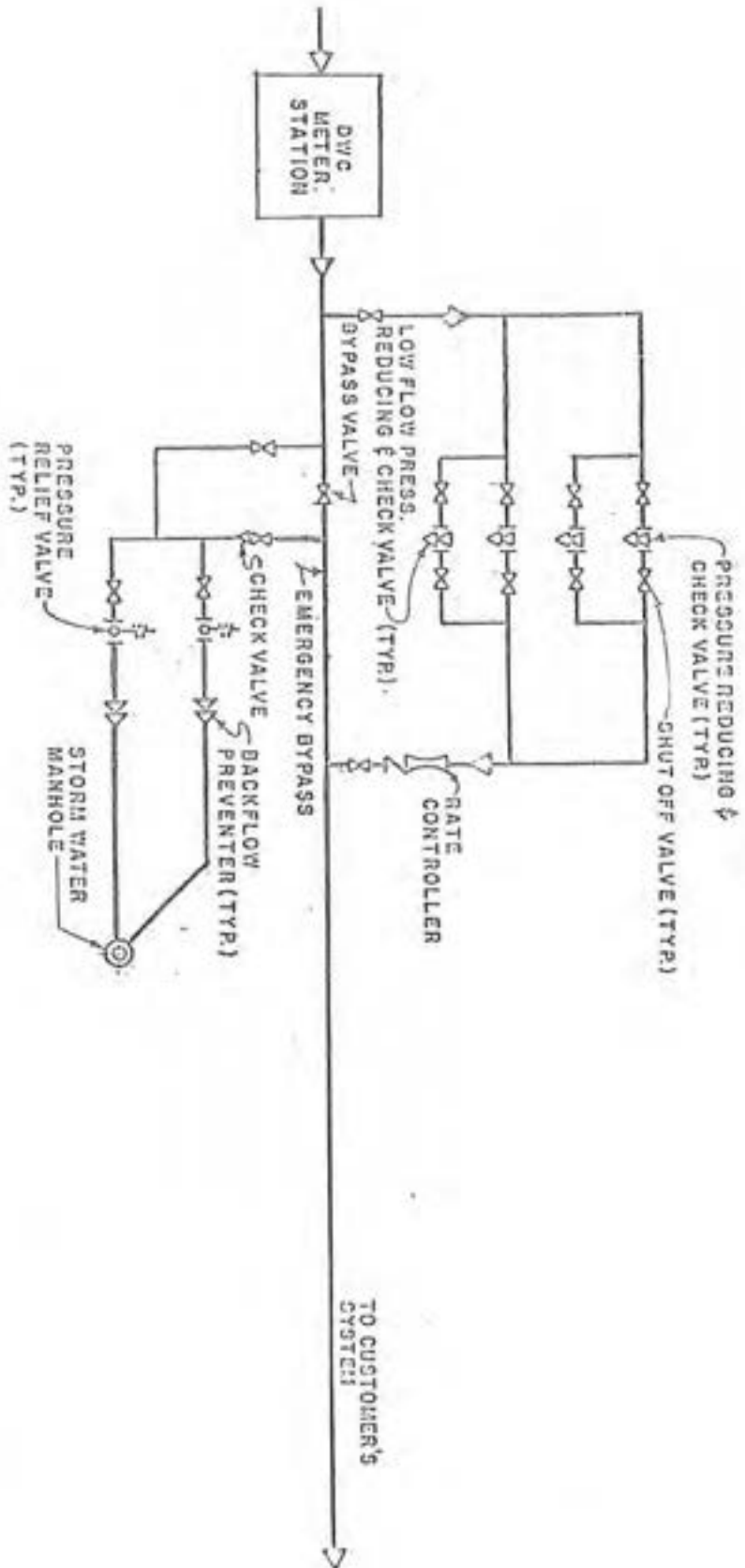

DUPAGE WATER COMMISSION
DATE:

ALVORD, BURDICK & HOWSON
ENGINEERS CHICAGO

EXHIBIT B-1 YORKVILLE UNIT SYSTEM CONNECTION FACILITIES

RATE CONTROL STATION - TYPE D

- 1) HOURLY FLOWS SHALL BE UNIFORM THROUGHOUT EACH DAY* AND RATE NOT EXCEED 1.7 X AVERAGE DAY FLOW AT THE STATION BASED ON CURRENT YEAR LAKE MICHIGAN WATER ALLOCATION.
- 2) RATE CONTROL STATION IS REQUIRED IF THE DIFFERENCE BETWEEN THE COMMISSION'S MINIMUM DESIGN PRESSURE** AND THE CUSTOMER'S DESIRED SYSTEM PRESSURE IS NOT MORE THAN TWELVE (12) P.S.I. (28 FT.).
- 3) RATE CONTROL STATION TYPE D - CONNECTIONS TO ELEVATED TANK AND SYSTEM.
 - A. PRESSURE SUSTAINING AND CHECK VALVE, AND RATE CONTROLLER (MAXIMUM FLOW LIMIT CONTROL) ARE REQUIRED.
 - B. PRESSURE RELIEF FOR BOTH DWC AND CUSTOMER'S SYSTEM IS REQUIRED.
 - C. EMERGENCY BYPASS IS REQUIRED.
 - D. ALTITUDE VALVE WITH BYPASS (CUSTOMER'S RESPONSIBILITY) IS RECOMMENDED FOR ELEVATED TANK CONNECTION. PROPER DAILY USE OF THE TANK IS REQUIRED.
 - E. CHLORINATION SYSTEM IS OPTIONAL (CUSTOMER'S RESPONSIBILITY).
- 4) EMERGENCY CONDITIONS MAY PERMIT 3X AVERAGE DAY FLOW AT THE STATION BASED ON 2020 LAKE MICHIGAN WATER ALLOCATION OR 1500 GPM WHICHEVER IS LARGER.
- 5) STANDBY PRESSURE SUSTAINING AND CHECK VALVE ARE REQUIRED.
- 6) THE FACILITY REQUIREMENTS INDICATED ARE FOR ILLUSTRATIVE PURPOSE SHOWING GENERAL GUIDELINES AND VARIOUS DESIGN FUNCTIONS TO BE PROVIDED. EACH STATION SHALL BE DESIGNED, AND PROPER EQUIPMENT SHALL BE SELECTED TO MEET LOCAL CONDITIONS AND SITE SPECIFICS.

*ACCOMPLISHED BY SETTING RATE CONTROLLER IN ACCORDANCE WITH THE CUSTOMER DEMAND.

**DESIGN PRESSURE WILL FLUCTUATE APPROXIMATELY \pm 10 FEET DEPENDING UPON COMMISSION'S ELEVATED STORAGE WATER ELEVATION.

SCHEMATIC OF PRESSURE INCREASING STATION TYPE D

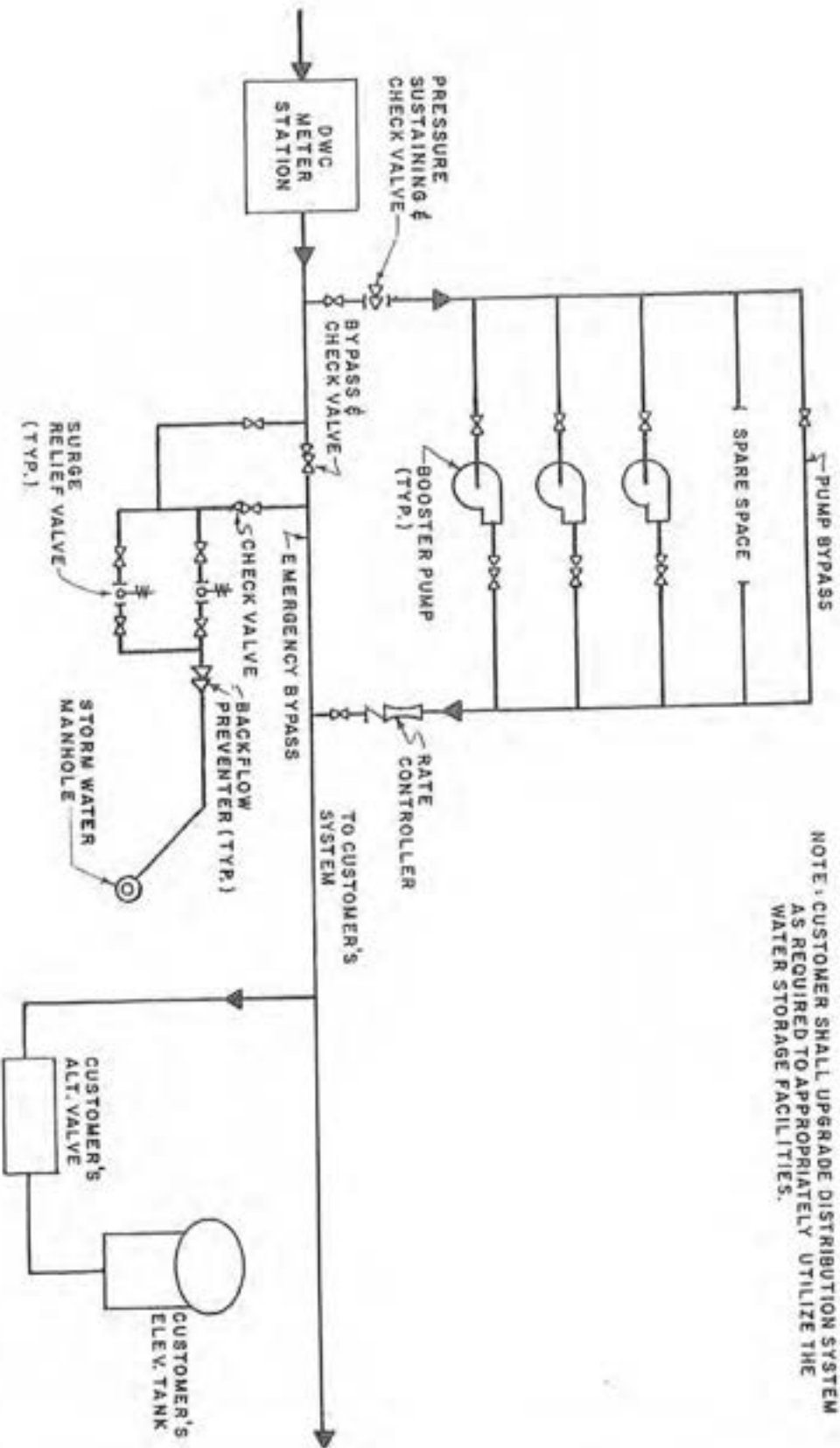

NOTE: CUSTOMER SHALL UPGRADE DISTRIBUTION SYSTEM AS REQUIRED TO APPROPRIATELY UTILIZE THE WATER STORAGE FACILITIES.

EXHIBIT B-1 YORKVILLE UNIT SYSTEM CONNECTION FACILITIES

DU PAGE WATER COMMISSION
DATE: 12-17-87

ALVORD, BURDICK & HOWSON
ENGINEERS CHICAGO

EXHIBIT B-2
COMMISSION CONNECTION FACILITIES

United City of Yorkville
Water Purchase and Sale Contract

EXHIBIT B-2 COMMISSION CONNECTION FACILITIES

TYPICAL 3-TRAM METER STATION LAYOUT

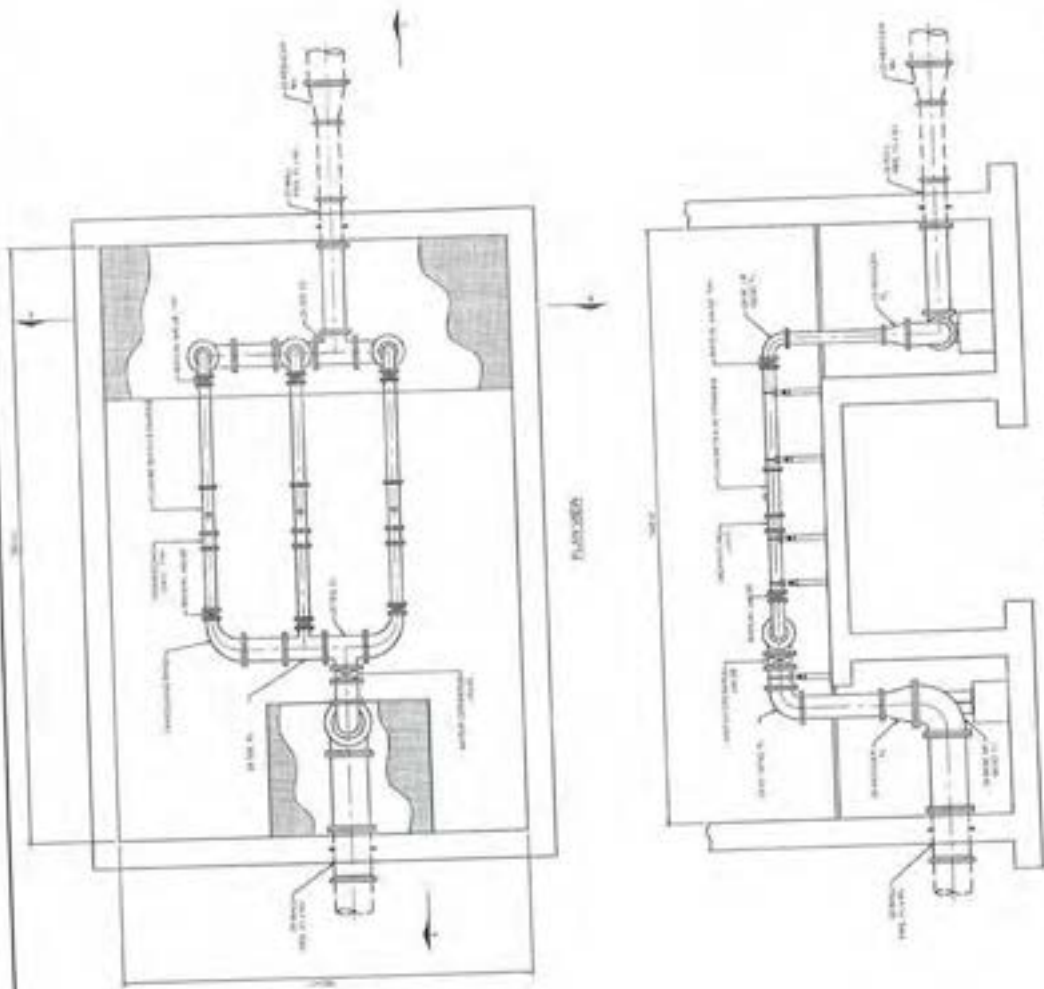

SECTION B-B

SECTION A-A

DATE: 11/10/10
DRAWN BY: J. W. B.

LEN
Robinson
Engineering

TITLE: 3-TRAM
METER STATION
COMMISSION CONNECTION FACILITIES

ENPAGE WATER COMMISSION
WATERLINE EXTENSION

WAS 21010K

NO.	REV.	DATE	BY	CHKD.	APP.

EXHIBIT C
YORKVILLE UNIT SYSTEM STORAGE REQUIREMENTS

United City of Yorkville
Water Purchase and Sale Contract

EXHIBIT C
CUSTOMER WATER STORAGE REQUIREMENTS

CUSTOMER	CUSTOMER EXISTING STORAGE (MG)	2030 ALLOCATION (MGD)	ALLOCATION AS A PERCENTAGE OF SYSTEM	STORAGE REQUIRED BY CONTRACT (MG)	30% SHALLOW WELL ALLOWANCE (MG)(1)	PORTION OF DWC STORAGE (MG)	STORAGE ABOVE OR (BELOW) REQUIREMENT (MG)
ADDISON	6.75	3.582	3.99%	7.16	0.72	2.50	2.80
ARGONNE	1.60	0.758	0.85%	1.52	0.15	0.53	0.76
BARTLETT	7.50	3.246	3.62%	6.49	0.65	2.25	3.92
BENSENVILLE	3.55	1.907	2.13%	3.81	0.00	1.33	1.07
BLOOMINGDALE	4.80	2.348	2.62%	4.70	0.47	1.64	2.21
CAROL STREAM	6.50	3.667	4.09%	7.33	0.73	2.56	2.46
IAWC ARROWHEAD	0.40	0.145	0.16%	0.29	0.03	0.10	0.24
IAWC COUNTRY CLUB	0.20	0.105	0.12%	0.21	0.02	0.07	0.08
IAWC DU PAGE/USLE	0.76	0.470	0.52%	0.94	0.09	0.33	0.24
IAWC LOMBARD	0.05	0.050	0.06%	0.10	0.01	0.03	(0.01)
IAWC VALLEY VIEW	0.88	0.520	0.58%	1.04	0.10	0.36	0.31
IAWC LIBERTY RIDGE WEST	0.40	0.300	0.33%	0.60	0.06	0.21	0.07
IAWC LIBERTY RIDGE EAST	0.05	0.030	0.03%	0.06	0.01	0.02	0.02
CLARENDON HILLS	1.25	0.818	0.91%	1.64	0.16	0.57	0.35
DARIEN /DPC-SERWF	4.00	3.269	3.65%	6.54	0.65	2.28	0.39
DOWNS GROVE	8.00	6.097	6.80%	12.19	1.22	4.25	1.28
DUPAGE COUNTY	2.63	1.483	1.65%	2.97	0.30	1.03	0.99
ELMHURST	15.00	4.083	4.55%	8.17	0.82	2.85	10.50
GLENDALE HEIGHTS	4.70	2.671	2.98%	5.34	0.53	1.86	1.75
GLEN ELLYN	3.25	2.562	2.86%	5.12	0.51	1.79	0.42
HINSDALE	4.50	2.468	2.75%	4.94	0.49	1.72	1.78
ITASCA	3.50	1.486	1.66%	2.97	0.30	1.04	1.86
USLE	5.50	2.686	3.00%	5.37	0.54	1.87	2.54
LOMBARD	5.60	4.174	4.66%	8.35	0.83	2.91	1.00
NAPERVILLE	43.90	17.454	19.47%	34.91	3.49	12.17	24.65
OAK BROOK	8.00	3.294	3.67%	6.59	0.66	2.30	4.37
OAKBROOK TERRACE	0.50	0.261	0.29%	0.52	0.05	0.18	0.21
ROSELLE	1.75	1.866	2.08%	3.73	0.37	1.30	(0.31)
VILLA PARK	3.80	1.784	1.99%	3.57	0.00	1.24	1.48
WESTMONT	4.50	2.552	2.85%	5.10	0.51	1.78	1.69
WHEATON	7.26	4.846	5.40%	9.09	0.97	3.38	1.92
WILLOWBROOK	4.00	1.031	1.15%	2.06	0.21	0.72	2.86
WINFIELD	1.60	0.916	1.02%	1.83	0.18	0.64	0.59
WOOD DALE	3.35	1.244	1.39%	2.49	0.25	0.87	1.98
WOODRIDGE	6.15	3.058	3.41%	6.12	0.61	2.13	2.78
YORKVILLE (2)	4.05	2.432	2.71%	4.86	0.49	1.70	1.37
CUSTOMER TOTAL STORAGE	180.23	89.663	100.00%	174.46	16.71	62.50	79.23
DWC SYSTEM STORAGE	62.50						
TOTAL CUSTOMER AND DWC STORAGE	242.73						

(1) Customer Shallow Well Allowance and Storage Requirements are audited annually for compliance.

(2) Yorkville is currently in preliminary design phase to add 4.0 MG of new storage in 2027 and decommissioning 0.5 MG storage in 2029.

EXHIBIT D
METER STATION AND ACCESS EASEMENTS

United City of Yorkville
Water Purchase and Sale Contract

EXHIBIT D
METER STATION AND ACCESS EASEMENTS
(FORM OF)

DUPAGE WATER COMMISSION
METERING STATION
EASEMENT AGREEMENT
[Meter Station Name]

[PERMANENT REAL ESTATE TAX INDEX NO. XX-XX-XXX-XXX]

Prepared by and Mail to:

Paul D. May, PE
General Manager
DuPage Water Commission
600 East Butterfield Road
Elmhurst, Illinois 60126-4642
630-834-0100

METERING STATION
EASEMENT AGREEMENT
[Meter Station Name]

THIS EASEMENT AGREEMENT, made and entered into this ____ day of _____, 202_, by and between the DUPAGE WATER COMMISSION, a county water commission created and existing under the laws of the State of Illinois (the "Commission") and the *[MUNICIPALITY]*, a unit of local government created and existing under the laws of the State of Illinois and a customer of the Commission (the "Customer").

WITNESSETH:

WHEREAS, the Commission and the Customer have entered into a certain Water Purchase and Sale Contract dated as of October 17, 2024 (the "Contract"); and

WHEREAS, the Contract provides that the Commission is to furnish, install, own, operate, maintain, and repair certain equipment and devices, together with certain structures and portions of its water distribution main, including underground feeder pipeline and related equipment, for properly conveying and measuring the quantity of Lake Michigan water delivered by the Commission to the Customer at the connection point provided for under the Contract (collectively referred to as the "Metering Station"); and

WHEREAS, the Contract provides that the Metering Station is to be located at a site selected and provided by the Customer, subject to review and approval by the Commission; and

WHEREAS, the Customer has selected the site legally described in Exhibit 1 attached hereto and by this reference incorporated herein and made a part hereof (the "Metering Station Easement Premises") for the location of the Metering Station as

generally depicted in Exhibit 2 attached hereto and by this reference incorporated herein and made a part hereof; and

WHEREAS, the Commission has reviewed the Metering Station Easement Premises and approved the same for the location of the Metering Station; and

WHEREAS, the Commission has submitted to the Customer for review the drawings and specifications for the Metering Station; and

WHEREAS, the Commission and the Customer desire to enter into this Easement Agreement in order to provide the Commission with a sufficient property interest in the Metering Station Easement Premises to fulfill the provisions and purpose of the Contract;

WHEREAS, the Commission has duly adopted its Ordinance No. **[O-XX-XX]**, being "An Ordinance Requesting the Intergovernmental Transfer of Easement Rights for the **[Municipality]** Metering Station MS-**[XXX]** Site and Authorizing the Execution of the **[Municipality]** Metering Station Easement Agreement," pursuant to the Local Government Property Transfer Act, 50 ILCS 605/0.01 et seq.; and

WHEREAS, the Customer has duly adopted its Resolution No. **[TBD]**, being "A Resolution Approving the Intergovernmental Transfer of Easement Rights to the DuPage Water Commission," pursuant to the Local Government Property Transfer Act, 50 ILCS 605/0.01 et seq.;

NOW, THEREFORE, in consideration of the foregoing and for other good and valuable consideration, the receipt and sufficiency of which is hereby acknowledged, and in the exercise of their powers and authority under the intergovernmental cooperation provisions of Article VII, Section 10 of the Illinois Constitution of 1970 and the Intergovernmental Cooperation Act, 5 ILCS 220/1 et seq., and other applicable authority, the Commission and the Customer hereby agree as follows:

1. The foregoing recitals are hereby incorporated herein as substantive provisions of this Easement Agreement.

2. The Customer hereby grants, conveys, warrants, and dedicates to the Commission, its successors and assigns, an exclusive perpetual easement to construct, furnish, install, own, operate, maintain, test, inspect, remove, repair, and replace the Metering Station at, in, under, and upon the Metering Station Easement Premises, together with all reasonable rights of ingress and egress along or across any adjoining lands of, or under the jurisdiction and control of, the Customer. The Customer hereby further grants, conveys, warrants, and dedicates to the Commission, its successors and assigns, a non-exclusive perpetual access easement along and across the real property legally described in Exhibit 1 attached hereto and by this reference incorporated herein and made a part hereof (the "Access Easement Premises"). The Customer hereby further grants, conveys, warrants, and dedicates to the Commission, its successors and assigns, a non-exclusive perpetual utility access easement along and across the real property legally described in Exhibit 1 attached hereto and by this reference incorporated herein and made a part hereof (the "Utility Access Easement Premises").

3. The Metering Station shall be not located, constructed, or maintained in any manner not in substantial conformity with Exhibit 2 without the express consent of the Customer, which consent shall not be unreasonably withheld.

4. The Customer hereby further grants to the Commission a temporary construction easement for the installation of the Metering Station upon, along, and across the real property legally described in Exhibit 3 attached hereto and by this reference incorporated herein and made a part hereof (the "Subject Property"). Said temporary construction easement shall be used by the Commission only during periods of actual

installation, replacement or repair activity and for any necessary restoration of the Metering Station Easement Premises.

5. The Commission shall exercise the easement rights hereby granted with due care, and shall not unreasonably interfere with, damage, or harm any Customer property located upon the Subject Property or Customer's adjacent property.

6. After construction of the Metering Station, the Metering Station Easement Premises shall be restored in accordance with the drawings and specifications for the Metering Station. All fences, roads, landscaping, and improvements shall be restored to former condition by the Commission if disturbed or altered in any manner by construction or maintenance activities of the Commission.

7. The Customer hereby reserves the right to use the Metering Station Easement Premises, the Access Easement Premises, the Utility Access Easement Premises, and its adjacent property in any manner that will not prevent or interfere in any way with the exercise by the Commission of the rights granted hereunder; provided, however, that the Customer shall not in any manner disturb, damage, destroy, injure, obstruct, or permit to be obstructed the Metering Station Easement Premises, the Access Easement Premises, or the Utility Access Easement Premises without the express prior written consent of the Commission, nor shall the Customer permanently or temporarily improve, damage, or obstruct the Metering Station Easement Premises, the Access Easement Premises, or the Utility Access Easement Premises in any manner that would impair the exercise by the Commission of the rights hereby granted.

8. To the fullest extent permitted by law, the Customer agrees to indemnify and defend the Commission with respect to any and all claims or damages to persons or property which may arise from the acts of the Customer, or its agents or employees, at

the Metering Station Easement Premises, the Access Easement Premises, the Utility Access Easement Premises, the Subject Property, and its adjacent property in conjunction with its rights pursuant to Paragraph 7 hereof, and, except as otherwise provided in the Contract, the Commission agrees to indemnify and defend the Customer with respect to any and all claims of damages to persons or property which may arise from the of the Commission, or its agents or employees, at the Metering Station Easement Premises, the Access Easement Premises, the Utility Access Easement Premises and the Subject Property in conjunction with its rights pursuant to Paragraphs 2, 4, 5 and 7 hereof. The Customer shall provide to the Commission, and the Commission shall provide to the Customer, a certificate of insurance or proof of self-insurance coverage as evidence of its continuing ability to meet the obligation established in this Paragraph, and both shall maintain such coverage at all times.

9. This Easement Agreement shall constitute and stand in the place of all Customer permits required of the Commission or its contractor to construct, furnish, install, own, operate, maintain, test, inspect, repair, remove, or replace the Metering Station at, in, under, and upon the Metering Station Easement Premises, and the Customer hereby agrees to execute any and all additional documents, approvals, waivers, or consents, if any, that may be reasonably necessary for the Commission to secure any permits required from any county, state, or federal agency for or in connection with constructing, furnishing, installing, owning, operating, maintaining, testing, inspecting, repairing, removing, or replacing the Metering Station.

10. In the event that the Contract is terminated without renewal with respect to the Customer, the Commission shall, within 90 days execute and deliver to the Customer an appropriate document evidencing the termination of this Easement Agreement and

releasing the easement rights hereby granted. The Commission may, within said 90 day period, in its own discretion, and at the Customer's expense, remove the Metering Station from the Metering Station Easement Premises. If the Commission fails to remove the **[Municipality]** Metering Station, as aforesaid, the Customer may take title to the Metering Station.

11. All rights, title, and privileges herein granted, including all benefits and burdens, shall run with the land and shall be binding upon and inure to the benefit of the parties hereto and their respective grantees, successors, assigns, and legal representatives.

12. All representations and warranties contained herein shall survive the execution of this Easement Agreement and the recordation hereof and shall not be merged.

IN WITNESS WHEREOF, the parties hereto have caused this instrument to be executed by their proper representatives duly authorized to execute the same.

DUPAGE WATER COMMISSION

ATTEST:

By: _____
Paul May, PE
General Manager

Danna Mundall
Clerk

[MUNICIPALITY]

By: _____
[NAME]
[Village/City President/Mayor]

ATTEST:

By: _____

Its: _____

EXHIBIT 1

LEGAL DESCRIPTIONS OF THE
METERING STATION EASEMENT PREMISES

PERMANENT METER STATION EASEMENT:

[INSERT LEGAL DESCRIPTION PROVIDED BY CUSTOMER]

PERMANENT ACCESS EASEMENT:

[INSERT LEGAL DESCRIPTION PROVIDED BY CUSTOMER]

EXHIBIT 1

LEGAL DESCRIPTIONS OF THE
METERING STATION EASEMENT PREMISES

PERMANENT UTILITY ACCESS EASEMENT:

[INSERT LEGAL DESCRIPTION PROVIDED BY CUSTOMER]

EXHIBIT 2

PLANS FOR METERING STATION

[PROVIDED BY THE COMMISSION]

EXHIBIT 2-A

MS ELEVATION DRAWINGS

[PROVIDED BY THE COMMISSION]

EXHIBIT 2-B

MS FLOOR PLANS

[PROVIDED BY THE COMMISSION]

EXHIBIT 2-C

MS SECTION DRAWINGS

[PROVIDED BY THE COMMISSION]

EXHIBIT 3

LEGAL DESCRIPTION OF THE TEMPORARY CONSTRUCTION
EASEMENT PREMISES

TEMPORARY CONSTRUCTION EASEMENT:

[INSERT LEGAL DESCRIPTION PROVIDED BY CUSTOMER]

STATE OF ILLINOIS)
) SS
COUNTY OF COOK)

I, _____, a Notary Public in and for said County, in the State aforesaid, do hereby certify that Paul D. May, personally known to me to be the General Manager of the DuPage Water Commission, and Danna M. Mundall, personally known to me to be the Clerk of the DuPage Water Commission, and personally known to me to be the same persons whose names are subscribed to the foregoing instrument, appeared before me this day in person and acknowledged that he/she signed, sealed, and delivered said instrument as his/her free and voluntary act, and as the free and voluntary act of said Commission, for the uses and purposes therein set forth.

Given under my hand and official seal this _____ day of _____, 202_.

Notary Public

My Commission Expires: _____

STATE OF ILLINOIS)
) SS
COUNTY OF [])

I, _____, a Notary Public in and for said County, in the State aforesaid, do hereby certify that **[Name]**, personally known to me to be the **[Title]** of the **[Municipality]**, and _____, personally known to me to be the _____ of the Village of Oswego, and personally known to be the same persons whose names are subscribed to the foregoing instrument, appeared before me this day in person and acknowledged that they signed, sealed, and delivered said instrument as their free and voluntary act, and as the free and voluntary act of said Village, for the uses and purposes therein set forth.

Given under my hand and official seal this _____ day of _____, 202_.

Notary Public

My Commission Expires: _____

EXHIBIT E
CAPITAL COST RECOVERY CHARGE

United City of Yorkville
Water Purchase and Sale Contract

EXHIBIT E

CAPITAL COST RECOVERY CHARGE

DuPage Water Commission
Calculation of Capital Cost Recovery Charge as of May 1, 2024
For Yorkville

<u>Fixed Assets (Audited as of 04-30-2024)</u>	
Land	\$ 11,728,902
Infrastructure	383,618,530
Buildings	110,194,197
Office Equipment	4,763,332
Machinery	27,061,530
Vehicles	1,055,314
CIP	<u>15,415,869</u>
Total	\$553,837,674
Less: Feeder Mains & Meter Stations	<u>94,321,158</u>
	459,516,516
Less: Total Rebates	<u>106,326,287</u>
Total	<u>\$353,190,229</u>

	MGD		<u>Total Capital Cost Recovery Charge</u>
Oswego (CY2022-CY2023 Avg)	2.505	3.128%	\$ 11,047,790
Montgomery (CY2022-CY2023 Avg)	2.267	2.831%	\$ 9,998,815
Yorkville (CY2022-CY2023 Avg)	1.817	2.269%	\$ 8,013,886
DuPage Water Commission (CY2022-CY2023 Avg)	73.483		
Total	<u>80.071</u>		\$ 29,060,491

EXHIBIT F
SCHEDULE OF EVENTS

United City of Yorkville
Water Purchase and Sale Contract

EXHIBIT F

YORKVILLE ILLUSTRATIVE SCHEDULE OF EVENTS

WEEKS>>	0	20	24	26
I. YORKVILLE DUTIES	(CONTRACT SIGNED)			Convey all required easements and interests to DWC (Section 10G)
A. Property Interests	Commence acquisition of necessary interests (Section 10G)			
B. Yorkville Connection Facilities		Submit plans and specs for DWC review (Section 10A)	DWC completes review (Section 10A)	
C. Water Storage Facilities (Not Applicable)				
II. DWC DUTIES				
A. Property Interests				
B. Commission Connection Facilities				Commence Design upon receipt of all required easements and interests (Section 10H)
III. OTHER EVENTS				
A. Delivery of Water				
B. Payment of Costs other than O&M				
C. Payment of O&M Costs				

EXHIBIT F

YORKVILLE ILLUSTRATIVE SCHEDULE OF EVENTS

WEEKS>>	41	52	156	185
I. YORKVILLE DUTIES				
A. Property Interests				
B. Yorkville Connection Facilities	Projected IEPA and Local Approvals	Commence construction of Customer Connection Facilities (Section 10C)	Complete construction of Customer Connection Facilities (Section 10C)	
C. Water Storage Facilities (Not Applicable)				
II. DWC DUTIES				
A. Property Interests				
B. Commission Connection Facilities				Complete Construction of Commission Connection Facilities (May 1, 2028)
III. OTHER EVENTS				
A. Delivery of Water				Commence Delivery of Lake Water
B. Payment of Costs other than O&M				Yorkville's First payment due at 1 st billing cycle after earlier of delivery of water or 12 months after Commission Connection Facilities substantially completed. (Section 7M)
C. Payment of O&M Costs				Yorkville's First payment due at 1 st billing cycle after substantial completion of Commission Connection Facilities (Section 7M)

EXHIBIT G
WATERLINK PROJECT ESCROW INTERGOVERNMENTAL AGREEMENT

United City of Yorkville
Water Purchase and Sale Contract

**WATERLINK PROJECT
ESCROW INTERGOVERNMENTAL AGREEMENT**

This WaterLink Project Escrow Intergovernmental Agreement (the “WaterLink Project Escrow Agreement” or this “Agreement”) is dated the 17th day of October 2024 between the Village of Montgomery (“Montgomery”), the Village of Oswego (“Oswego”), and the United City of Yorkville (“Yorkville”) (Oswego, Montgomery, and Yorkville are collectively referred to herein as the “WaterLink Communities”) and the DuPage Water Commission (the “Commission”), a county water commission and public corporation under Division 135 of Article 11 of the Illinois Municipal Code, 65 ILCS 5/11-135-1 *et seq.*, and the Water Commission Act of 1985, 70 ILCS 3720/0.01 *et seq.* (the “Acts”).

WITNESSETH:

WHEREAS, the Commission has been organized under the Acts to supply water within its territorial limits; and

WHEREAS, the WaterLink Communities currently own and operate municipal drinking water systems served by wells that extract source water from the Ironton-Galesville aquifer; and

WHEREAS, the WaterLink Communities are within the territorial limits of the Commission; and

WHEREAS, the WaterLink Communities intend to change from the Ironton-Galesville groundwater source to Lake Michigan source water, through water purchase and sale agreements with the Commission, and have applied for and been awarded Lake Michigan Water Allocation Permits from the State of Illinois Department of Natural Resources, Office of Water Resources for each discrete and non-contiguous service area served by each WaterLink Community’s Unit System (“Service Area”); and

WHEREAS, the WaterLink Communities have conducted extensive study and have concluded that the most sustainable alternative water source to serve the WaterLink Communities through the municipal waterworks systems currently serving the WaterLink Communities, as well as any extensions or improvements of those systems, is Lake Michigan water from the Commission; and

WHEREAS, the Commission owns and maintains a waterworks system as a supplier of Lake Michigan water to member customers that contract for such service ("Commission's Waterworks System"); and

WHEREAS, the parties seek to complete the improvements necessary to connect the Commission's Waterworks System to the WaterLink Communities' individual Unit Systems in 2028; and

WHEREAS, the Commission has entered into a Water Supply Contract with the City of Chicago to purchase Lake Michigan water sufficient to meet the water supply needs of the Commission and its customers; and

WHEREAS, the Commission's Water Supply Contract with the City of Chicago is set to expire in 2041, and the Commission is currently: (1) exploring an alternative solution to obtaining Lake Michigan water; and (2) in discussions and negotiations with the City of Chicago for a new Water Supply Contract; and

WHEREAS, to carry out their duties and responsibilities, and desire to create a method of providing an adequate supply of Lake Michigan water to the Service Area, the Commission and each of the WaterLink Communities, contemporaneously with this Agreement are entering into Water Purchase and Sale Contracts (the "Water Purchase Agreements") and this Agreement incorporates the defined terms of the Water Purchase Agreements unless otherwise specified herein; and

WHEREAS, to become a member of the Commission and comply with the Water Purchase Agreements, each WaterLink Community must pay its proportional share of the costs for the property owned by the Commission; and

WHEREAS, contemporaneously with this Agreement, the WaterLink Communities and the Commission are each entering into a Capital Cost Recovery Agreements that establish the terms and conditions for financing each WaterLink Community's proportional share of the costs for the property owned by the Commission; and

WHEREAS, contemporaneously with this Agreement, each WaterLink Community and the Commission are entering into an Intergovernmental Agreement Concerning the Development of Connection Facilities to Implement Water Service (the "Development Agreement"); and

WHEREAS, the WaterLink Communities intend that certain provisions within this Agreement be used only to the extent that one or all of the WaterLink Communities have failed to properly fund this Agreement after notice has been provided in accordance with this Agreement; and

WHEREAS, the Commission will incur in connection with (i) the design, bidding, contracting, managing, and actual construction, installation, removal, relocation, replacement, extension, or improvement of the Connection Facilities, including without limitation equipment required for the operation of the Connection Facilities and all administrative, financing, supervisory, inspection, engineering, surveying, and legal fees, costs, and expenses associated therewith; (ii) the acquisition and divestment of lands, easements, and rights of way over lands and waters necessary for the construction, installation, removal, relocation, replacement, extension, or improvement of the Connection Facilities, and all administrative, title, surveying, and legal fees, costs, and expenses associated therewith; and (iii) the review and processing of plans and agreements for the construction, installation, removal, relocation, replacement, extension, or improvement of the Connection Facilities and in connection with the negotiation, preparation, consideration, and review of this Contract, including without limitation all legal, engineering, consulting, and administrative fees, costs, and expenses associated therewith; except as any of the above are included in Operation and Maintenance Costs ("Connection Facilities Cost"); and

WHEREAS, the Commission and the WaterLink Communities have previously entered into First and Second Escrow Intergovernmental Agreements (the "Prior Escrow Agreements") for what is defined under those Prior Escrow Agreements as Phase 1 and Phase 2 Services; and

WHEREAS, prior to the execution of documents requiring the expenditure of Commission Expenses, the Commission requires the WaterLink Communities to establish an additional escrow fund with the Commission as stated herein to provide a funding source for the Commission Expenses beyond those incurred for the Phase 1 and Phase 2 Services; and

WHEREAS, pursuant to the Development Agreement, the WaterLink Communities will be responsible for the Connection Facilities Cost; and

WHEREAS, the WaterLink Communities have previously agreed to each Municipality's percentage share of the Connection Facilities Cost pursuant to an Intergovernmental Cost Share Agreement (the "Cost Share Agreement"). The WaterLink Communities agree that the costs paid into the escrow account under this WaterLink Project Escrow Agreement will mirror the Division of Financial Responsibilities/Allocation of Costs set forth in the Cost Share Agreement. Specifically, Montgomery commits and agrees to pay 24.42%, Yorkville commits and agrees to pay 40.22%, and Oswego commits and agrees to pay 35.36%. The Commission is not a party to the Cost Share Agreement and has no responsibility or liability as to any true-up or adjusted accounting between the WaterLink Communities; and

WHEREAS, pursuant to Article VII, Section 10 of the Illinois Constitution of 1970, and the Intergovernmental Cooperation Act, 5 ILCS 220/1 et seq., the Commission and the WaterLink Communities are authorized to enter into this WaterLink Project Escrow Agreement.

NOW, THEREFORE, in consideration of the foregoing recitals and of the mutual covenants and agreements herein contained, the WaterLink Communities and the Commission hereby agree as follows:

1. The foregoing recitals are by this reference incorporated herein and made a part hereof as if fully set forth herein. Further, to the extent any capitalized terms in this Agreement are set forth as a defined term in the Water Purchase Agreements, the capitalized terms in this Agreement shall have the same meaning in this Agreement as the definition in the Water Purchase Agreements.

2. The Commission will establish a segregated escrow account for the sole purpose of funding the Connection Facilities Cost (the "Waterlink Project Escrow Account"). The WaterLink Communities will each deposit into the Waterlink Project Escrow Account all payments necessary to fund the Connection Facilities Cost. Any remaining funds from the prior Escrow Agreements will remain in the related escrow account, and any funds not expended or necessary for Phase I and Phase II Services, when those phases are complete, may be transferred

to the WaterLink Project Escrow Account, unless otherwise directed by the WaterLink Communities.

3. The Commission will draw from the WaterLink Project Escrow Account to pay for or reimburse any Connection Facilities Cost incurred.

4. The WaterLink Project Escrow Account will be insured and interest-bearing, and the Commission will provide the WaterLink Communities with Quarterly Statements within twenty-one (21) days after the end of each quarter: (1) showing the starting and ending balances for that quarter in the WaterLink Project Escrow Account; and (2) detailing the costs of Connection Facilities Cost incurred for that quarter including any amounts received or paid from the WaterLink Project Escrow Account. The WaterLink Communities will have the right to conduct audits for three years after the termination of this WaterLink Project Escrow Agreement relative to the WaterLink Project Escrow Account.

5. The Commission will keep a record of all pay requests from the WaterLink Project Escrow Account for reimbursement of Connection Facilities Cost incurred (the "Pay Request") and sufficient documentation of the Connection Facilities Cost incurred in support of the Pay Request. The documentation will be retained for review by the WaterLink Communities upon request and included within the Quarterly Statements issued by the Commission.

If at any time during the term of this WaterLink Project Escrow Agreement, the balance in the WaterLink Project Escrow Account is less than Thirty Million Dollars (\$30,000,000.00) (the "Minimum Balance Amount"), the Commission will notify the WaterLink Communities. Within thirty (30) days of the Commission notifying the WaterLink Communities under this Paragraph 5, the WaterLink Communities will each pay the Commission its proportionate share (as set forth in the Cost Share Agreement) of the request to ensure that the Minimum Balance is met. Failure to make such payment when required under this Paragraph 5 shall be considered a default of this Agreement by the WaterLink Communities.

6. The Commission will, after the execution and delivery of this Agreement, make available as a line of credit to the WaterLink Communities an amount not to exceed \$21,000,000

(the "Commitment Amount") to pay a portion of the Connection Facilities Cost as defined in the Water Purchase Agreements. The actual amounts of money borrowed by each of the WaterLink Communities pursuant to the Commitment Amount will constitute the "Line of Credit."

7. The WaterLink Communities will repay the principal balance of the Line of Credit, plus accrued and unpaid interest at the Interest Rate set forth in Paragraph 8 of this Agreement from the Interest Commencement Date through the Line of Credit Payment Commencement Date (the "Capitalized Interest"), as those terms are hereinafter defined on the unpaid principal balance, and any Capitalized Interest, of the Line of Credit from and after the Line of Credit Payment Commencement Date, as that term is hereinafter defined, in 240 monthly installments, commencing on the 10th day of every month (the "Monthly Payment Date") commencing on the Line of Credit Payment Commencement Date as hereafter defined in Paragraph 9 and continuing in successive monthly installments on each Monthly Payment Date in each month thereafter, with the final payment of any unpaid interest and principal, if not sooner paid, on the 240th Monthly Payment Date. Each of the 240 monthly installments of principal on the Line of Credit will be determined as of the last day of the month preceding the Monthly Payment Date in any given year during the term of the Line of Credit (a "Principal Determination Date") and will be determined by dividing the unpaid principal balance, and any Capitalized Interest, of the Line of Credit as of the applicable Principal Determination Date by the number of monthly installments of principal remaining to be paid during the term of the Line of Credit. The accrued and unpaid interest will be capitalized on a monthly basis until the Line of Credit Payment Commencement Date. There will be no penalty for prepayment.

8. Interest on the unpaid principal balance, and any Capitalized Interest, of the Line of Credit will accrue at a rate (the "Interest Rate") that is equivalent to the highest yield to maturity interest rate earned by the Commission (based on all investments) as reported monthly on the Commission's Schedule of Investments for the immediately preceding fiscal year (May 1 – April 30) as determined by the Commission (the "Earned Interest Rate") plus one percent (1%). Interest will only accrue on money actually borrowed under Paragraph 6 of this Agreement and will begin to accrue when the Commission makes its first draw on the Line of Credit for the WaterLink Communities (the "Interest Commencement Date"). The Interest Rate for each year that the Line

of Credit remains outstanding will be calculated on the basis of a calendar year consisting of 360 days of twelve 30-day months and will be adjusted on May 1st of each year, and will be applied to the outstanding unpaid principal balance, and any Capitalized Interest, as determined on the most recent Principal Determination Date, will be paid commencing on the Monthly Payment Date, and continuing on the Monthly Payment Date each month thereafter until the principal balance of the Line of Credit and all interest thereon has been paid in full.

9. Payments of principal and interest, including Capitalized Interest, will begin no later than the 10th day of the first month after the first delivery of potable, filtered water drawn from Lake Michigan to any of the WaterLink Communities individual Unit Systems as that term is defined in the Water Purchase Agreement (the "Line of Credit Payment Commencement Date").

10. Payments of the principal and interest will be made in lawful money of the United States of America in federal or other immediately available funds.

11. If at any time, the Commission receives invoices incurred arising out of the Connection Facilities Cost for which there are insufficient funds in the Construction Escrow Agreement, the Commission will pay the actual costs incurred from the Connection Facilities Cost Line of Credit. The Commission payments for the Connection Facilities Cost will be paid out of the Commitment Amount and will be immediately considered part of the Line of Credit. The Commission may make payments from the Line of Credit no more than once per month, on the 10th day of the month, provided that the Commission will give the WaterLink Communities notice (which notice must be received by the WaterLink Communities prior to 10:00 a.m., local time, 7 days prior to the requested borrowing date), specifying the amount to be paid and the payment date. It is anticipated that only a single borrowing will be requested each month. Each borrowing pursuant to this Agreement will be in an aggregate principal amount less than the Available Commitment. For purposes of this Paragraph 11, the Available Commitment at a particular time is an amount equal to the difference between the Commitment Amount and the aggregate principal balance of the Line of Credit then outstanding.

12. Subject to the limitations of Paragraph 12, the WaterLink Communities may, without premium or penalty, upon at least one business day's irrevocable notice to the

Commission, specifying the date and amount of prepayment, make such prepayment; and the payment amount specified in such notice will be due and payable on the date specified therein. The proceeds of any such prepayment will be applied by the Commission first, to the payment of accrued and unpaid interest, if any, on the Line of Credit, and second, to the payment of the unpaid principal balance of the Line of Credit. The WaterLink Communities will not be entitled to, nor receive any credit for, interest on any such prepayment.

13. The proceeds of the Line of Credit will be devoted to and used with due diligence for the purpose of paying the Connection Facilities Cost identified in Exhibit A; provided, however, that where an unexpended balance remains in any one or more of the various cost components of the Connection Facilities Cost detailed in Exhibit A attached hereto, such balance may be transferred and expended, in whole or in part, to and for any other cost component of the Connection Facilities Cost detailed in Exhibit A attached hereto.

14. The Covenants set forth in Subsections 9A, 9B, 9C, and 9D of the Water Purchase Agreements are incorporated into this Agreement by reference.

15. This WaterLink Project Escrow Agreement will terminate, and any monies not paid or incurred for Connection Facilities Cost, including any interest therein will be returned to the WaterLink Communities, unless mutually agreed to by the WaterLink Communities and the Commission, upon the earlier of:

- a. upon written request by the WaterLink Communities, a written direction that is issued by the General Manager of the Commission that the funds are no longer needed for any Connection Facilities Cost, which direction shall not be unreasonably withheld; or
- b. upon the WaterLink Communities' written notification to the Commission that they are no longer pursuing the purchase of Lake Michigan water from the Commission, and the payment of all the Connection Facilities Cost.

No monies will be returned to the WaterLink Communities until a full accounting has been completed of the expenditures incurred under this WaterLink Project Escrow Agreement.

16. If any WaterLink Community or the Commission defaults in the full and timely performance of any of its obligations hereunder, the non-breaching entity or entities, after first providing written notice to the breaching entity of the event of default and providing the breaching entity ten (10) days to cure the same, will be entitled to invoke its legal rights and remedies as a result thereof, including, but not limited to, its equitable remedy of specific performance. THE FOREGOING NOTWITHSTANDING, NO ENTITY WILL BE LIABLE TO ANOTHER ENTITY OR ANY OF ITS AFFILIATES, AGENTS, EMPLOYEES, OR CONTRACTORS FOR SPECIAL, INDIRECT, EXEMPLARY, INCIDENTAL, PUNITIVE, OR CONSEQUENTIAL DAMAGES.

17. There are no third-party beneficiaries of this WaterLink Project Escrow Agreement and nothing in this WaterLink Project Escrow Agreement, express or implied, is intended to confer on any person other than the Parties hereto (and their respective successors, heirs, and permitted assigns), any rights, remedies, obligations, or liabilities.

18. Any notices under this WaterLink Project Escrow Agreement will be personally delivered, delivered by the deposit thereof in the U. S. Postal Service, postage prepaid, registered, or certified, return receipt requested, or by overnight courier service to the Party at the address listed below or at another address hereafter designated by notice, or by email transmission. Any such notice will be deemed to have been delivered and given upon personal delivery or delivery by a nationally recognized overnight courier service, or deposit with the United States Postal Service or upon receipt of written confirmation that facsimile or email transmission has been successfully completed:

If to the Commission:

Paul D. May, P.E., General Manager
DuPage Water Commission
600 E. Butterfield Road
Elmhurst, IL 60126
Email: may@dpwc.org

With a copy to:

Phillip A. Luetkehans
Luetkehans, Brady, Garner & Armstrong, LLC
105 E. Irving Park Road
Itasca, IL 60143
Email: pal@lbgalaw.com

If to the WaterLink Communities:

Village Administrator
Village of Oswego
100 Parkers Mill
Oswego, IL 60543
Email: info@oswegoil.org

With a copy to:

David J. Silverman
Village Attorney
Mahoney, Silverman, & Cross, LLC
126 South Main Street
Oswego, Illinois 60543

Village Administrator
Village of Montgomery
200 N River Street
Montgomery, IL 60538
Email: zoephel@montgomeryil.org

With a copy to:

Laura M. Julien
Village Attorney
Mickey Wilson, Weiler, Renzi, Lenert, & Julien, PC
140 Municipal Drive
Sugar Grove, IL 60554

City Administrator
United City of Yorkville
800 Game Farm Road
Yorkville, IL 60560
Email: bolson@yorkville.il.us

With a copy to:

Kathleen Field Orr & Associates
Kathleen Field Orr
2024 Hickory Road, Suite 205
Homewood, IL 60430

With a copy to:

Irene Schild Caminer
Caminer Law, LLC
2612 W. Sunnyside Ave.
Chicago, IL 60625
Email: irene@caminerlaw.com

19. Each WaterLink Community will hold the Commission harmless and defend the Commission from any claims or litigation that arise out of the engineering, construction, property acquisition, and easement acquisitions for the Connection Facilities being constructed for the WaterLink Communities due to one of all of the WaterLink Communities' failure to comply with the payment obligations arising under this WaterLink Project Escrow Agreement.

20. Miscellaneous.

- a. This WaterLink Project Escrow Agreement shall be deemed to supplement the Water Purchase Agreements in connection with the supply of Lake Michigan water to the Waterlink Communities' individual Unit Systems. If there is any other conflict or inconsistency between the terms of this Agreement and the terms of the Water Purchase Agreements, then the terms of this WaterLink Project Escrow Agreement shall control. The WaterLink Communities shall at all times comply with all terms and conditions of the Water Purchase Agreements except as otherwise provided in this Agreement.

- b. Except as provided herein, the WaterLink Communities and the Commission will not assign this WaterLink Project Escrow Agreement or any right or privilege any WaterLink Communities and the Commission may have under this WaterLink Project Escrow Agreement without the prior written consent of all Parties hereto, not to be unreasonably withheld conditioned or delayed.
- c. This WaterLink Project Escrow Agreement shall be governed by and construed exclusively under the applicable laws, but not the conflict of laws rules, of the State of Illinois. Venue for any litigation arising out of this Agreement shall only be proper in the Eighteenth Judicial Circuit Court, DuPage County, Illinois.
- d. The person(s) executing this WaterLink Project Escrow Agreement on behalf of the Parties hereto warrant that: (i) each WaterLink Community and the Commission are duly organized and existing; (ii) the individual signing is duly authorized to execute and deliver this WaterLink Project Escrow Agreement on behalf of said WaterLink Community or the Commission; (iii) by so executing this WaterLink Project Escrow Agreement, such WaterLink Community and the Commission are formally bound to the provisions and conditions contained in this WaterLink Project Escrow Agreement; and (iv) the entering into this WaterLink Project Escrow Agreement by a WaterLink Community and the Commission does not violate any provision of any other agreement to which said WaterLink Community and the Commission is bound.
- e. Each WaterLink Community and the Commission acknowledge that it may be necessary to execute documents other than those specifically referred to herein in order to complete the objectives and requirements that are set forth in this WaterLink Project Escrow Agreement. Each WaterLink Community and the Commission hereby agree to cooperate with each other by executing such other documents or taking such other actions as may be reasonably necessary to complete the objectives and requirements set forth herein in accordance with the intent of each WaterLink Community and the Commission as evidenced by this WaterLink Project Escrow Agreement.

- f. This WaterLink Project Escrow Agreement is the entire agreement between the WaterLink Communities and the Commission regarding its subject matter and may not be changed or amended except pursuant to a written instrument signed by each WaterLink Community and the Commission.
- g. This WaterLink Project Escrow Agreement may be executed in any number of identical counterparts, each of which will be considered an original, but which together will constitute one and the same agreement.

IN WITNESS WHEREOF, each WaterLink Community and the Commission hereto have caused their respective corporate names to be subscribed hereto and their respective corporate seals to be affixed hereto and attested by their duly authorized officers.

ATTEST:

DuPage Water Commission

BY: _____

ATTEST:

Village of Montgomery

BY: _____

ATTEST:

Village of Oswego

BY: _____

ATTEST:

United City of Yorkville

BY: _____

EXHIBIT A

CONNECTION FACILITIES COST

WATERLINK PROJECT ESCROW INTERGOVERNMENTAL AGREEMENT

EXHIBIT A

CONNECTION FACILITIES COST ESTIMATE (1)

CONSTRUCTION (including 25% contingency)	\$210,389,827
PROPERTY INTERESTS/LAND ACQUISITION	\$17,477,530
LEGAL & ADMINISTRATIVE	\$1,000,000
ENGINEERING	\$28,000,000
	<hr/>
	\$256,867,357
COST ESCALATION OVER PROJECT DURATION	\$26,699,000
	<hr/>
ESTIMATED PROJECT COST (2)	\$283,566,357

- (1) COST ESTIMATE IS BASED UPON FORECASTED PROJECT COSTS AS OF THE DATE IDENTIFIED BELOW AND IS PROVIDED FOR REFERENCE ONLY. ACTUAL PROJECT COSTS WILL BE BASED UPON AWARDED PROJECT CONTRACT(S) AND ACTUAL REALIZED UNIT PRICE AND LUMP SUM COSTS, INCLUDING PROPERTY ACQUISITION, ENGINEERING, LEGAL AND COMMISSIONING COSTS, ALL OF WHICH HAVE BEEN ESTIMATED HEREIN BUT WILL NOT BE FINALLY DETERMINED UNTIL THE COMPLETION OF THE PROJECT AND FINAL COMMISSIONING.
- (2) BASED UPON ESTIMATES INCLUDED IN THE PROJECT DEVELOPMENT REPORT DATED FEBRUARY 1, 2024



Resolution #: R-60-24, R-61-24, R-62-24, R-63-24, R-64-24, and R-65-24

Account: N/A

Approvals: *Author / Manager / Finance / Admin*

REQUEST FOR BOARD ACTION

Date: 10/9/2024

Description: **Recommendation to Approve Water Purchase and Sales Agreement(s) and Capital Cost Recovery Charge Agreement(s) for the WaterLink communities of Oswego, Yorkville, and Montgomery**

Agenda Section: Administration Committee

Originating Department: Administration

I am pleased to present the WaterLink Customer Agreements for DWC Board consideration. The WaterLink communities have been working toward a new water source for over 10 years after becoming aware of impending water scarcity in the aquifer which provides their current supply. After extended study, the WaterLink partners (Oswego, Montgomery, and Yorkville), identified Lake Michigan source water delivered by the DuPage Water Commission as the preferred future source. This project will be one of the largest water projects in the Midwest, and will extend the DWC service area into Kendall counties with DWC water transmission infrastructure extending west of the Fox River upon completion.

The WaterLink communities have received IDNR allocations and have worked with DWC to fund Phase I and Phase II engineering over the last two years. During this period of time, the WaterLink communities have also been preparing financing instruments to fund the construction of the new infrastructure necessary to be constructed by DWC to convey water to the WaterLink communities. All project costs, including legal, engineering, property acquisition, construction, and commissioning will be funded by the WaterLink communities through a WaterLink Connection Facilities Agreement (R-66-24) and companion Project Escrow agreement (R-67-24), also included on this agenda.

The contract documents presented for approval have been crafted to provide continuity with previously approved Subsequent Customer Agreements to the greatest extent possible. DWC Legal Counsel and staff have worked closely with the WaterLink communities, their staff, and their legal counsel over many months to advance these documents for consideration. I wish to acknowledge and thank them for the significant effort that was provided to complete this task.

A summary of the primary elements of the Agreements is provided following:

Water Purchase and Sales Agreements (R-60-24, R-62-24, R-64-24):

The Water Purchase and Sale Agreement(s) have been constructed to provide a term that matches that of the other Contract Customers, ending February 24, 2064; and include language, terms, and conditions consistent with DWC Contract Customers. The project is scheduled for construction to commence in 2025 and to be commissioned in 2028. WaterLink communities will begin to access the new water source at that time, or as soon as permitted based upon achieving compliance with the IDNR water loss regulations.

Capital Cost Recovery Charge Agreements (R-61-24, R-63-24, R-65-24):

All new (subsequent) DWC customers are required to provide a Capital Cost Recovery Charge (aka “buy-in fee”) to ensure parity with the original Charter Customers which paid for the original DWC system upon formation. The Capital Cost Recovery Charged is determined by computing each customer’s pro-rata share by utilizing their IDNR allocation to calculate their demand as a percentage of the whole, and multiplying that percentage by the value of all DWC fixed assets as of the most recently audited fiscal year (FYE 2024). Based upon these computations, the Capital Cost Recovery Charges to be collected are as follows:

Oswego:	\$11,047,790
Montgomery:	\$ 9,998,815
Yorkville:	\$ 8,013,886

Companion Agreements:

In addition to the 1) Water Purchase and Sale Contract(s) and 2) Capital Cost Recovery Charge Agreement(s) for each of three WaterLink Communities, there are also two additional agreements for which there are four parties/signatories: the Village of Oswego, the Village of Montgomery, the United City of Yorkville, and the DuPage Water Commission. These items are included on the DWC October 17, 2024 DWC Agenda and are listed below:

- Resolution R-66-24: WaterLink Connection Facilities Intergovernmental Agreement
- Resolution R-67-24: WaterLink Project Escrow Agreement

Recommended Motion:

It is recommended that the DWC Board approve the Water Purchase and Sales Agreement(s) and the Capital Cost Recovery Charge Agreement(s) for the WaterLink communities of Oswego, Montgomery, and Yorkville.

DUPAGE WATER COMMISSION

RESOLUTION NO. R-63-24

A RESOLUTION APPROVING AN INTERGOVERNMENTAL AGREEMENT WITH THE UNITED CITY OF YORKVILLE CONCERNING CAPITAL COST RECOVERY CHARGE

WHEREAS, the Commission was formed and exists pursuant to the Water Commission Act of 1985, 70 ILCS 3720/0.01 et seq., and Division 135 of Article 11 of the Illinois Municipal Code, 65 ILCS 5/11-135-1 et seq., for the purpose of securing an adequate source and supply of water for its customers; and

WHEREAS, the Village of Montgomery (“Montgomery”), the Village of Oswego (“Oswego”) and the United City of Yorkville (“Yorkville”) (Oswego, Montgomery and Yorkville are collectively referred to herein as the “Municipalities”) desire to supply Lake Michigan water to their residents by connecting to the Commission’s waterworks system (the “Project”); and

WHEREAS, the Commission and Yorkville have negotiated an Intergovernmental Agreement Concerning Capital Cost Recovery Charge and a Water Purchase and Sale Contract for the Project; and

WHEREAS, concurrently with the enactment of this Resolution, the Commission and the Municipalities are entering into an Intergovernmental Agreement Concerning Development of Connection Facilities to Implement Water Service for the Project;

WHEREAS, concurrently with the enactment of this Resolution, the Commission and the Municipalities are entering into a WaterLink Project Escrow Intergovernmental Agreement with the Municipalities for the Project; and

WHEREAS, the Commission deems it to be in the best interests of the Commission and the public to complete the Project and enter into the Intergovernmental Agreement with the United City of Yorkville Concerning Capital Cost Recovery Charge.

NOW, THEREFORE, BE IT RESOLVED by the Board of Commissioners of the DuPage Water Commission as follows:

SECTION ONE: The Board of Commissioners of the DuPage Water Commission hereby approves the Intergovernmental Agreement with the United City of Yorkville Concerning Capital Cost Recovery Charge attached hereto as Exhibit 1 and authorizes the Chairman to execute the agreement on behalf of the DuPage Water Commission and to take whatever steps necessary to effectuate the terms of said agreement.

SECTION TWO: This Resolution shall be in full force and effect after passage and approval as required by law.

	Aye	Nay	Absent	Abstain
Bouckaert, D.				
Cuzzone, N.				
Fennell, J.				
VACANT	_____			
Novotny, D.				
Pruyn, J.				
Romano, K.				
Rush, K.				
Russo, D.				
Saverino, F.				
Suess, P.				
Van Vooren, D.				
Zay, J.				

ADOPTED THIS _____ DAY OF _____, 2024.

ATTEST:

James F. Zay, Chairman

Danna Mundall, Clerk

Board/Resolutions/2024/R-63-24.docx

EXHIBIT 1

INTERGOVERNMENTAL AGREEMENT WITH THE UNITED CITY OF YORKVILLE CONCERNING CAPITAL COST RECOVERY CHARGE

This Intergovernmental Agreement, (the “Agreement”) is dated the 17th day of October 2024 (the “Effective Date”), by and between the United City of Yorkville (“City”) and the DuPage Water Commission (the “Commission”), a county water commission and public corporation under Division 135 of Article 11 of the Illinois Municipal Code, 65 ILCS 5/11-135-1 *et seq.*, and the Water Commission Act of 1985, 70 ILCS 3720/0.01 *et seq.* (the “Acts”).

W I T N E S S E T H:

WHEREAS, the Commission has been organized under the Acts to supply water within its territorial limits; and

WHEREAS, the City currently owns and operates a municipal drinking water system (“Yorkville Unit System”) served by wells that extract source water from the Ironton-Galesville aquifer; and

WHEREAS, the City is within the territorial limits of the Commission; and

WHEREAS, the City intends to change from the Ironton-Galesville groundwater source to Lake Michigan source water, through a Water Purchase and Sale Contract with the DuPage Water Commission, and has applied for and received a Lake Michigan Water Allocation Permit (“Permit”) from the State of Illinois Department of Natural Resources, Office of Water Resources; and

WHEREAS, the City has conducted extensive study and has concluded that the most sustainable alternative water source to serve the City through the municipal waterworks system currently serving the City, as well as any extensions or improvements of that system, is Lake Michigan water from the Commission; and

WHEREAS, the Commission owns and maintains a waterworks system as a supplier of

Lake Michigan water to member customers that contract for such service (“Commission’s Waterworks System”); and

WHEREAS, the City is seeking to obtain water for its residents beginning in 2028 from the Commission in the incorporated areas within the City (the “Service Area”); and

WHEREAS, the City seeks to connect to Lake Michigan through the Commission; and

WHEREAS, the Commission has entered into a water supply contract with the City of Chicago to purchase Lake Michigan water sufficient to meet the water supply needs of the Commission and its customers; and

WHEREAS, the Commission’s water supply contract with the City of Chicago is set to expire in 2041 and the Commission is currently: (1) exploring an alternative solution to obtaining Lake Michigan water; and (2) in discussions and negotiations with the City of Chicago for a new water supply agreement; and

WHEREAS, to carry out their duties and responsibilities, and desire to create a method of providing an adequate supply of Lake Michigan water to the Yorkville Unit System, the Commission, and the City, concurrent with this Agreement, are entering into the Water Purchase and Sale Contract dated October 17, 2024, WaterLink Project Escrow Intergovernmental Agreement, and an Intergovernmental Agreement Concerning Development of Connection Facilities to Implement Water Service; and

WHEREAS, to become a member of the Commission and comply with the Water Purchase and Sale Contract, the City must pay its proportional share of the costs for the property owned by the Commission (the “Capital Cost Recovery Charge”); and

WHEREAS, the Commission previously enacted Resolution R-79-04 allowing the Commission the ability to finance the Capital Cost Recovery Charge for potential Subsequent

Customers (customers other than its original customers) requesting such accommodation on a case-by case basis; and

WHEREAS, the matters set forth in this Agreement will serve the public interest, and the Commission and the City deem it to be in each of their best interests for the Commission to provide financing to the City for the money necessary to pay the Capital Cost Recovery Charge and enter into this Agreement; and

WHEREAS, pursuant to Section 10 of Article VII of the Illinois Constitution of 1970, the provisions of the Intergovernmental Cooperation Act, 5 ILCS 220/1 *et seq.*, and other applicable authority, the Commission and the City are authorized to enter into this Agreement.

NOW, THEREFORE, in consideration of the foregoing and the mutual covenants and agreements hereinafter set forth, the Commission and the City hereby agree as follows:

SECTION 1. PREAMBLES

The foregoing recitals are by this reference incorporated herein and made a part hereof as if fully set forth herein.

SECTION 2. COMMISSION FINANCING

A. Capital Cost Recovery Financing. The Commission will, after the execution and delivery of this Agreement, provide financing to the City in the amount of \$8,013,886.00 (the “Capital Cost Recovery Amount”).

B. Payment Terms.

1. The City will pay the Commission the principal balance of the Capital Cost Recovery Amount in 360 monthly installments, commencing at the time the first payment is due under Subsection 7M in the Water Purchase and Sale Contract (the “Monthly Payment Date”), and continuing in successive monthly installments on each Monthly Payment Date, with the final

payment of any principal, if not sooner paid, on the 360th Monthly Payment Date. Each of the 360 monthly installments of principal for the Capital Cost Recovery Amount will be in the amount of \$22,260.79, except that the final payment will be in the amount of \$22,262.39.

2. Interest on the unpaid principal balance of the Capital Cost Recovery Amount, will accrue at the rate of zero percent (0%) per annum.

C. Tender of Capital Cost Recovery Amount Payments. Payments of the principal of and interest will be made in lawful money of the United States of America in federal or other immediately available funds.

D. Asset-in-Kind Contribution. To the extent the City agrees to pay for a portion of the increase in size of the primary 48” western pipeline (commencing at Book Road and 75th Street and extending west of the Fox River to a termination point at Orchard Road, also known as “TW 6/25” in the DWC naming convention), from the baseline pipe size to 54”, the value of that contribution by the City will be mutually agreed upon and set forth in a separate agreement between the Commission and the City before the closing of the WIFIA Loan.

E. Covenants. The covenants set forth in Subsections 9A, 9B, 9C, and 9D of the Water Purchase and Sale Contract are incorporated into this Agreement by reference.

SECTION 3. DEFAULTS AND REMEDIES

A. Commission Defaults. The occurrence of the following will constitute a default by the Commission under this Agreement: The failure by the Commission to observe and/or perform any covenant, condition, and/or agreement on its part to be observed and/or performed under this Agreement, and the continuation of said failure for thirty (30) days after the Commission’s receipt of written notice thereof from the City. However, if said failure cannot be remedied by the Commission within said thirty (30) day period and the Commission has diligently pursued the

resolution of the failure during said thirty (30) days, the period will be extended by such additional time as may be reasonably required by the Commission to cure or correct said failure. In no event will the period be extended by more than ninety (90) days. In the event of a default by the Commission under this Agreement, the City will have the same remedies as are provided for, and only the remedies provided for, in the Water Purchase and Sale Contract for a default by the Commission.

B. City Defaults. The occurrence of the following will constitute a default by the City under this Agreement:

1. The failure by the City to observe and/or perform any covenant, condition, and/or agreement on its part to be observed and/or performed under this Agreement, and the continuation of said failure for thirty (30) days after the City's receipt of written notice thereof from the Commission. However, if said failure cannot be remedied by the City within said thirty (30) day period and the City has diligently pursued the resolution of the failure during said thirty (30) days, the period will be extended by such additional time as may be reasonably required by the City to cure or correct said failure. In no event will the period be extended by more than ninety (90) days. In the event of a default by the City under this Agreement, the Commission will have the same remedies as are provided for, and only the remedies provided for, in the Water Purchase and Sale Contract for a default by the City;
2. A default under the October 17, 2024 Intergovernmental Agreement Concerning Development of Connection Facilities to Implement Water Service; or

3. A default under the October 17, 2024 WaterLink Project Escrow Intergovernmental Agreement.

In the event of a default by the City, the Commission will: (i) be paid its reasonable attorneys' fees and costs incurred in connection with that default, in addition to any attorneys' fees and costs incurred in enforcing the terms of this Agreement; (2) be entitled to the right to enforce a lien against all income derived from the Yorkville Unit System, other than that income necessary to pay any loans to the State of Illinois or its agencies for the construction of the Yorkville Unit System, until the City's Capital Cost Recovery Amount and any amounts due from the City under the WaterLink Project Escrow Intergovernmental Agreement are paid back in full; and (3) will have the same remedies as are provided for in the Water Purchase and Sale Contract for a default by the City.

C. Force Majeure. In case by reason of a force majeure event, either party to this Agreement will be rendered unable wholly or in part to carry out its obligation under this Agreement, then if such party will give notice and full particulars of such force majeure event in writing to the other party within a reasonable time after occurrence of the event or cause relied on, the obligation of the party giving such notice, so far as it is affected by such force majeure event, will be suspended during the continuance of the inability then claimed, but for no longer period, and any such party will endeavor to remove or overcome such inability with all reasonable dispatch. The term "force majeure event" as employed in this Agreement will mean acts of God, strikes, lockouts, or other industrial disturbances, acts of public enemy, orders of any kind of the Government of the United States, of the State of Illinois, or of any civil or military authority, insurrections, riots, epidemics, pandemics, landslides, lightning, earthquakes, fires, hurricanes, storms, floods, washouts, droughts, arrests, restraints of government and people, civil disturbances, explosions, breakage or accidents to machinery, pipelines, canals, or tunnels, partial or entire

failure of water supply, and inability on the part of the Commission or of the City to deliver Lake Michigan water, or of the City to receive Lake Michigan water, on account of any other causes not reasonably within the control of the party claiming such inability. The settlement of strikes and lockouts will be entirely within the discretion of the party having the difficulty, and the above requirement that any “force majeure event” will be remedied with all reasonable dispatch will not require the settlement of strikes and lockouts by acceding to the demands of the opposing party or parties when such settlement is unfavorable to it in the judgment of the party having the difficulty.

SECTION 4. LEGAL RELATIONSHIPS AND REQUIREMENTS

A. Supplemental Agreement. This Agreement will be deemed to supplement the Water Purchase and Sale Contract in connection with the supply of Lake Michigan water to the Yorkville Unit System. If there is any other conflict or inconsistency between the terms of this Agreement and the terms of the Water Purchase and Sale Contract, then the terms of this Agreement will control. The City will at all times comply with all terms and conditions of the Water Purchase and Sale Contract, except as otherwise provided in this Agreement.

B. Term of Agreement. This Agreement will continue in full force and effect from the Effective Date until the Capital Cost Recovery Amount is paid in full by the City.

C. Cooperation and Further Agreements. The Commission and the City agree to cooperate in good faith throughout the term of this Agreement to implement the letter and spirit of the provisions set forth in this Agreement.

D. Assignment. This Agreement may not be assigned by any party, in whole or in part, without the prior written consent of the other party.

E. Notices. Any notices under this Agreement will be personally delivered, delivered by the deposit thereof in the U. S. Postal Service, postage prepaid, registered, or certified, return receipt requested, or by overnight courier service to the Party at the address listed below or at

another address hereafter designated by notice, or by email transmission. Any such notice will be deemed to have been delivered and given upon personal delivery or delivery by a nationally recognized overnight courier service, or deposit with the United States Postal Service or upon receipt of written confirmation that facsimile or email transmission has been successfully completed:

If to the Commission:

Paul D. May, P.E., General Manager
DuPage Water Commission
600 E. Butterfield Road
Elmhurst, IL 60126
Email: may@dpwc.org

With a copy to:

Phillip A. Luetkehans
Luetkehans, Brady, Garner & Armstrong
2700 International Drive, Suite 305
West Chicago, IL 60185
Email: pal@lbgalaw.com

If to the City:

City Administrator
United City of Yorkville
800 Game Farm Road
Yorkville, IL 60560
Email: bolson@yorkville.il.us

With a copy to:

City Attorney
Kathleen Field Orr
Kathleen Field Orr & Associates
2024 Hickory Road, Suite 205
Homewood, IL 60430

With a copy to:

Irene Schild Caminer
Caminer Law, LLC
2612 W. Sunnyside Ave.
Chicago, IL 60625
Email: Irene@caminerlaw.com

By notice complying with the requirements of this Section 4.E, the Commission and the City each will have the right to change the address or addressee or both for all future notices to it, but no notice of a change of address will be effective until actually received.

F. No Oral Agreements. No oral agreements exist by or between the Commission and the City with respect to this Agreement, nor was the making and execution of this Agreement induced by any representation, statement, warranty, agreement, or action other than those expressed or explicitly referenced in this Agreement.

G. No Waiver. No course of dealing or failure of the Commission or the City to enforce strictly any term, right, or condition of this Agreement will be construed as a waiver of such term, right, or condition. No express waiver of any term, right, or condition of this Agreement will operate as a waiver of any other term, right, or condition.

H. No Third-Party Beneficiaries. This Agreement is entered into solely for the benefit of the contracting parties, and nothing in this Agreement is intended, either expressly or impliedly, to provide any right or benefit of any kind whatsoever to any person or entity who is not a party to this Agreement, or to acknowledge, establish, or impose any legal duty to any third party.

I. Governing Law and Venue. This Agreement will be governed by and construed exclusively under the applicable laws, but not the conflict of laws rules, of the State of Illinois. Venue for any litigation arising out of this Agreement will only be proper in the Eighteenth Judicial Circuit Court, DuPage County, Illinois.

J. Counterparts. This Agreement may be executed in several counterparts, each of which will be deemed to be an original, and all of which will constitute but one and the same instrument. Any such counterpart may be signed by one or more of the parties hereto so long as each of the parties hereto has signed one or more of such counterparts.

K. Authority. The person(s) executing this Agreement on behalf of the Parties hereto warrant that: (i) such the City and the Commission are duly organized and existing; (ii) the individual signing is duly authorized to execute and deliver this Agreement on behalf of said City or the Commission; (iii) by so executing this Agreement, such City and the Commission are formally bound to the provisions and conditions contained in this Agreement; and (iv) the entering into this Agreement by the City and the Commission does not violate any provision of any other agreement to which said City and the Commission is bound.

L. Mutual Cooperation. The City and the Commission acknowledge that it may be necessary to execute documents other than those specifically referred to herein in order to complete the objectives and requirements that are set forth in this Agreement. The City and the Commission hereby agree to cooperate with each other by executing such other documents or taking such other actions as may be reasonably necessary to complete the objectives and requirements set forth herein in accordance with the intent of the City and the Commission as evidenced by this Agreement.

M. Amendment. This Agreement is the entire agreement between the City and the Commission regarding its subject matter and may not be changed or amended except pursuant to a written instrument signed by the City and the Commission.

IN WITNESS WHEREOF, the City and the Commission hereto have caused their respective corporate names to be subscribed hereto and their respective corporate seals to be affixed hereto and attested by their duly authorized officers.

ATTEST:

DuPAGE WATER COMMISSION

By: _____

By: _____

Its: _____

Its: _____

ATTEST:

UNITED CITY OF YORKVILLE

By: _____

By: _____

Its: _____

Its: _____



Resolution #: R-60-24, R-61-24, R-62-24, R-63-24, R-64-24, and R-65-24

Account: N/A

Approvals: *Author / Manager / Finance / Admin*

REQUEST FOR BOARD ACTION

Date: 10/9/2024

Description: **Recommendation to Approve Water Purchase and Sales Agreement(s) and Capital Cost Recovery Charge Agreement(s) for the WaterLink communities of Oswego, Yorkville, and Montgomery**

Agenda Section: Administration Committee

Originating Department: Administration

I am pleased to present the WaterLink Customer Agreements for DWC Board consideration. The WaterLink communities have been working toward a new water source for over 10 years after becoming aware of impending water scarcity in the aquifer which provides their current supply. After extended study, the WaterLink partners (Oswego, Montgomery, and Yorkville), identified Lake Michigan source water delivered by the DuPage Water Commission as the preferred future source. This project will be one of the largest water projects in the Midwest, and will extend the DWC service area into Kendall counties with DWC water transmission infrastructure extending west of the Fox River upon completion.

The WaterLink communities have received IDNR allocations and have worked with DWC to fund Phase I and Phase II engineering over the last two years. During this period of time, the WaterLink communities have also been preparing financing instruments to fund the construction of the new infrastructure necessary to be constructed by DWC to convey water to the WaterLink communities. All project costs, including legal, engineering, property acquisition, construction, and commissioning will be funded by the WaterLink communities through a WaterLink Connection Facilities Agreement (R-66-24) and companion Project Escrow agreement (R-67-24), also included on this agenda.

The contract documents presented for approval have been crafted to provide continuity with previously approved Subsequent Customer Agreements to the greatest extent possible. DWC Legal Counsel and staff have worked closely with the WaterLink communities, their staff, and their legal counsel over many months to advance these documents for consideration. I wish to acknowledge and thank them for the significant effort that was provided to complete this task.

A summary of the primary elements of the Agreements is provided following:

Water Purchase and Sales Agreements (R-60-24, R-62-24, R-64-24):

The Water Purchase and Sale Agreement(s) have been constructed to provide a term that matches that of the other Contract Customers, ending February 24, 2064; and include language, terms, and conditions consistent with DWC Contract Customers. The project is scheduled for construction to commence in 2025 and to be commissioned in 2028. WaterLink communities will begin to access the new water source at that time, or as soon as permitted based upon achieving compliance with the IDNR water loss regulations.

Capital Cost Recovery Charge Agreements (R-61-24, R-63-24, R-65-24):

All new (subsequent) DWC customers are required to provide a Capital Cost Recovery Charge (aka “buy-in fee”) to ensure parity with the original Charter Customers which paid for the original DWC system upon formation. The Capital Cost Recovery Charged is determined by computing each customer’s pro-rata share by utilizing their IDNR allocation to calculate their demand as a percentage of the whole, and multiplying that percentage by the value of all DWC fixed assets as of the most recently audited fiscal year (FYE 2024). Based upon these computations, the Capital Cost Recovery Charges to be collected are as follows:

Oswego:	\$11,047,790
Montgomery:	\$ 9,998,815
Yorkville:	\$ 8,013,886

Companion Agreements:

In addition to the 1) Water Purchase and Sale Contract(s) and 2) Capital Cost Recovery Charge Agreement(s) for each of three WaterLink Communities, there are also two additional agreements for which there are four parties/signatories: the Village of Oswego, the Village of Montgomery, the United City of Yorkville, and the DuPage Water Commission. These items are included on the DWC October 17, 2024 DWC Agenda and are listed below:

- Resolution R-66-24: WaterLink Connection Facilities Intergovernmental Agreement
- Resolution R-67-24: WaterLink Project Escrow Agreement

Recommended Motion:

It is recommended that the DWC Board approve the Water Purchase and Sales Agreement(s) and the Capital Cost Recovery Charge Agreement(s) for the WaterLink communities of Oswego, Montgomery, and Yorkville.

DUPAGE WATER COMMISSION

RESOLUTION NO. R-64-24

A RESOLUTION APPROVING A WATER PURCHASE AND SALE CONTRACT
WITH THE VILLAGE OF MONTGOMERY

WHEREAS, the Commission was formed and exists pursuant to the Water Commission Act of 1985, 70 ILCS 3720/0.01 et seq., and Division 135 of Article 11 of the Illinois Municipal Code, 65 ILCS 5/11-135-1 et seq., for the purpose of securing an adequate source and supply of water for its customers; and

WHEREAS, the Village of Montgomery (“Montgomery”), the Village of Oswego (“Oswego”) and the United City of Yorkville (“Yorkville”) (collectively the “Municipalities”) desire to supply Lake Michigan water to their residents by connecting to the Commission’s waterworks system (the “Project”); and

WHEREAS, the Commission and Montgomery have negotiated an Intergovernmental Agreement Concerning Capital Cost Recovery Charge and a Water Purchase and Sale Contract for the Project; and

WHEREAS, concurrently with the enactment of this Resolution, the Commission and the Municipalities are entering into an Intergovernmental Agreement Concerning Development of Connection Facilities to Implement Water Service for the Project; and

WHEREAS, concurrently with the enactment of this Resolution, the Commission and the Municipalities are entering into a WaterLink Project Escrow Intergovernmental Agreement with the Municipalities for the Project; and

WHEREAS, the Commission deems it to be in the best interests of the Commission and the public to complete the Project and enter into the Water Purchase and Sale Contract with Montgomery.

NOW, THEREFORE, BE IT RESOLVED by the Board of Commissioners of the DuPage Water Commission as follows:

SECTION ONE: The Board of Commissioners of the DuPage Water Commission hereby approves the Water Purchase and Sale Contract with the Village of Montgomery attached hereto as Exhibit 1 and

authorizes the Chairman to execute the Water Purchase and Sale Contract on behalf of the DuPage Water Commission and to take whatever steps necessary to effectuate the terms of said agreement.

SECTION TWO: This Resolution shall be in full force and effect after passage and approval as required by law.

	Aye	Nay	Absent	Abstain
Bouckaert, D.				
Cuzzone, N.				
Fennell, J.				
VACANT	_____			
Novotny, D.				
Pruyn, J.				
Romano, K.				
Rush, K.				
Russo, D.				
Saverino, F.				
Suess, P.				
Van Vooren, D.				
Zay, J.				

ADOPTED THIS _____ DAY OF _____, 2024.

James F. Zay, Chairman

ATTEST:

Danna Mundall, Clerk

Board/Resolutions/2024/R-64-24.docx

EXHIBIT 1

DUPAGE WATER COMMISSION

WATER PURCHASE AND SALE CONTRACT

Between

The DuPage Water Commission

and

The Village of Montgomery

FOR THE VILLAGE OF MONTGOMERY UNIT SYSTEM

October 17, 2024

**DUPAGE WATER COMMISSION
WATER PURCHASE AND SALE CONTRACT
WITH THE VILLAGE OF MONTGOMERY**

Table of Contents

	Page
SECTION 1. PREAMBLES	5
SECTION 2. DEFINITIONS.....	5
SECTION 3. WATER SUPPLY.....	16
A. Agreement to Sell and Purchase.....	16
B. Beginning of Obligations to Deliver and Receive Lake Water	16
C. Limits on Supply	17
D. Emergency or Maintenance Turn-Off	17
E. Curtailment; Emergency Use of Other Sources	18
F. Water Quality	19
SECTION 4. DELIVERY; STORAGE	19
A. Montgomery Unit System Connection Facilities	19
B. Storage.....	20
C. Metering of Shallow Wells.....	21
D. Surges and Back-Flows	22
E. Maintenance of System; Water Quality; Prevention of Waste.....	22
SECTION 5. MEASURING EQUIPMENT	22
A. Metering Station and Instrumentation	22
B. Records	24
C. Calibration	24
D. Check Meters	25
E. Meter Malfunctions.....	25
F. Removal of Metering Station and SCADA System Facilities.....	27
SECTION 6. UNIT OF MEASUREMENT	27
SECTION 7. PRICES AND TERMS OF PAYMENT	27
A. Operation and Maintenance Costs Payment.....	27
B. Fixed Costs Payment	28
C. Connection Facilities Cost Payment.....	29
D. Capital Cost Recovery Charge Payment.....	30
E. Underconsumption Costs Payment.....	31

	Page
F. Default Shares.....	31
G. Bills and Due Date.....	32
H. Disputed Payments.....	32
I. Interest on Overdue Payments.....	33
J. Security Deposit.....	34
K. Prepayments.....	35
L. Enforcement of Provisions Hereof by Other Customers.....	37
M. Beginning of Obligation to Pay.....	38
 SECTION 8. SPECIAL CONDITIONS AND COVENANTS.....	 39
A. Construction of the Commission Connection Facilities; No Delay Damages; Supply of Lake Water.....	 39
B. Lake Water Only; Costs.....	40
C. Title to Lake Water.....	40
D. Emergency Supply.....	40
E. Covenants to Be Set Out in Bond Ordinance.....	40
F. Payments Hereunder are an Operational Expense of the Montgomery Unit System.....	 41
 SECTION 9. ADDITIONAL MONTGOMERY COVENANTS.....	 42
A. Maintenance of Corporate Existence.....	42
B. Maintenance and Operation of Montgomery Unit System.....	42
C. Rate Covenant.....	43
D. Future Subordination of Obligations.....	43
E. General Covenant to Operate Properly.....	44
F. Accounting and Audit.....	44
G. Maintain Ownership of Montgomery Unit System.....	44
H. Insurance.....	45
I. Continue to Serve.....	45
J. Maintain Water Allocation.....	45
K. Release and Indemnification.....	46
L. Combining or Separating System Accounts.....	46
M. Rate of Withdrawal.....	47
N. Emergency Interconnections.....	47
 SECTION 10. SCHEDULE FOR COMPLETION OF VARIOUS FACILITIES.....	 50
A. Plans and Specifications for Montgomery Unit System Connection Facilities.....	 50
B. IEPA and Other Approvals for Montgomery Unit System Connection Facilities.....	 51

	Page
C. Commencement of Construction of Montgomery Unit System Connection Facilities	51
D. Intentionally Omitted.....	51
E. Intentionally Omitted.....	51
F. Intentionally Omitted.....	51
G. Transfer of Property Rights	51
H. Commencement of Construction of Commission Connection Facilities	52
I. Delivery of Water for Start-Up Purposes	52
J. Illustrative Schedule of Events	53
SECTION 11. ASSIGNABILITY.....	54
SECTION 12. FORCE MAJEURE	54
SECTION 13. COMMISSION DEFAULTS	56
SECTION 14. MONTGOMERY OBLIGATION UNCONDITIONAL.....	56
SECTION 15. COOPERATION IN CONSTRUCTION; EASEMENTS.....	57
SECTION 16. COOPERATION IN ISSUANCE OF BONDS	58
SECTION 17. REGULATORY BODIES	58
SECTION 18. OTHER WATER SUPPLIERS.....	59
SECTION 19. NOTICES; EVIDENCE OF ACTIONS; WAIVER.....	59
A. Notices	59
B. Evidence of Actions	60
C. Waiver	60
D. Partial Invalidity	60
SECTION 20. EFFECTIVE DATE; TERMINATION; PAYMENT OF INTERIM COSTS; TERM.....	61
A. Effective Date	61
B. Commission Right to Terminate	61
C. Payment of Interim Costs	62
D. Term	63
SECTION 21. GOVERNING LAW AND VENUE.....	63
SECTION 22. MUNICIPAL BOUNDARIES.....	63

	Page
SECTION 23. MODIFICATIONS OR AMENDMENTS	64
SECTION 24. EXHIBITS INCORPORATED.....	64
SECTION 25. EXECUTION IN COUNTERPARTS	64

**DUPAGE WATER COMMISSION
WATER PURCHASE AND SALE CONTRACT WITH THE VILLAGE
MONTGOMERY
FOR THE VILLAGE OF MONTGOMERY UNIT SYSTEM**

This Water Purchase and Sale Contract (“Contract”), dated as of October 17, 2024, by and between the **DUPAGE WATER COMMISSION**, DuPage, Cook, and Will Counties, State of Illinois (the “Commission”), a county water commission and public corporation under Division 135 of Article 11 of the Illinois Municipal Code, 65 ILCS 5/11-135-1 *et seq.*, and the Water Commission Act of 1985, 70 ILCS 3720/1 *et seq.* (collectively, the “Acts”), and the **VILLAGE OF MONTGOMERY**, Kane and Kendall Counties, Illinois, a municipal corporation duly organized and existing under the laws of the State of Illinois (“Montgomery”);

WITNESSETH:

WHEREAS, the Commission has been organized under the Acts to supply water within its territorial limits; and

WHEREAS, the Commission owns and maintains a waterworks system as a supplier of Lake Michigan water to member customers that contract for such service; and

WHEREAS, Montgomery currently owns and operates a municipal drinking water system served by wells that extract source water from the Ironton-Galesville aquifer; and

WHEREAS, Montgomery is within the territorial limits of the Commission; and

WHEREAS, Montgomery, together with the Village of Oswego and the United City of Yorkville (collectively the “WaterLink Communities”), conducted extensive

study and concluded that the most sustainable alternative water source to serve the WaterLink Communities through the municipal waterworks systems currently serving the WaterLink Communities, as well as any extensions or improvements of those systems is Lake Michigan water from the Commission; and

WHEREAS, Montgomery (along with the WaterLink Communities) has applied for and received from the State of Illinois Department of Natural Resources, Office of Water Resources, a Lake Michigan water allocation permit, for the Montgomery Unit System; and

WHEREAS, Montgomery is in the process of designing and constructing the conversion of its waterworks system that will be owned and operated by Montgomery and extended or improved from time to time to meet the potable water requirements of all residents and businesses to be served with water from Montgomery, which waterworks system is preliminarily depicted in Exhibit A attached to this Contract; and

WHEREAS, the Commission and the WaterLink Communities have entered into Escrow Agreements and have been taking steps to finance, study, engineer, design, and construct the facilities necessary for the WaterLink Communities to receive Lake Michigan water, and the Commission has been taking steps to study, finance, engineer, design, and construct the Commission Connection Facilities (as defined herein) to deliver Lake Michigan water to the WaterLink Communities; and

WHEREAS, contemporaneously with this Agreement, the WaterLink Communities and the Commission are entering into a WaterLink Project Escrow Intergovernmental Agreement, an Intergovernmental Agreement with the Village of

Montgomery Concerning Capital Cost Recovery Charge, and an Intergovernmental Agreement Concerning Development of Connection Facilities to Implement Water Service; and

WHEREAS, the WaterLink Communities have started Optimal Corrosion Control Treatment (OCCT) Studies of their water systems to be filed with the Illinois Environmental Protection Agency. The Commission and Montgomery acknowledge that the OCCT Study, including recommendations for infrastructure improvements that may be needed as a result of recommendations for optimized corrosion control treatment, will not be completed and reviewed by IEPA until approximately October 2025; and

WHEREAS, Montgomery and the Commission recognize that construction may begin pending the results of the OCCT Study; and

WHEREAS, Montgomery desires that its waterworks system preliminarily depicted in Exhibit A attached to this Contract as well as any extensions or improvements of that system (the “Montgomery Unit System”) be served with water from the Commission beginning sometime in or before 2032 as mutually agreed to by the parties; and

WHEREAS, the Commission has entered various water supply contracts with the City of Chicago to purchase Lake Michigan water sufficient to meet the water supply needs of the Commission and its customers (the “Water Supply Contract”) and most recently in 2024 and extends until 2041; and

WHEREAS, at some point during the term of this Contract, the Commission may

build alone or with others a water treatment, distribution, and transmission system to obtain Lake Michigan water directly from Lake Michigan that will serve the Commission; and

WHEREAS, the Commission has issued and sold and may further propose to issue and sell Bonds (as defined in Section 2 below) from time to time during the term of this Contract in sufficient amounts for the payment of the costs of its project of acquiring, designing, constructing, and maintaining its Waterworks System (as defined in Section 2 below); and

WHEREAS, such Bonds have been and may be issued in the future from time to time by the Commission pursuant to Bond Ordinances (as defined in Section 2 below) adopted by the Commission; and

WHEREAS, pursuant to the Acts, Article VII, Section 10 of the Illinois Constitution of 1970, the Intergovernmental Cooperation Act, 5 ILCS 220/1 *et seq.*, and the Public Utilities Act, 220 ILCS 5/1 *et seq.* as amended, the Commission and Montgomery are authorized to enter into this Contract; and

WHEREAS, by the execution of this Contract, Montgomery is surrendering none of its rights to the ownership and operation of the Montgomery Unit System, except as expressly provided for, and only to the limited extent so provided for, in this Contract, and Commission is surrendering none of its rights to the ownership and operation of its Waterworks System, but each asserts its continued right to operate such systems; and

WHEREAS, Montgomery recognizes that the Commission may use this Contract

as the basis, in part, for obtaining loans from time to time to be evidenced by the issuance of its Bonds; and for payment of the principal of and the premium, if any, and interest on such Bonds; and as the means for the payment of its maintenance and operating expenses; and for such purposes as may be authorized by applicable statutes or required in any Bond Ordinance adopted by the Commission authorizing issuance of Bonds; and

WHEREAS, Montgomery recognizes that the Commission may in the future enter into contracts with other customers that are members of or may join the Commission.

NOW, THEREFORE, in consideration of the foregoing recitals and of the mutual covenants and agreements herein contained, the Commission and Montgomery hereby agree as follows:

SECTION 1. PREAMBLES.

The preambles hereto are hereby incorporated herein by this reference and are made fully a part of this Contract.

SECTION 2. DEFINITIONS.

The following words and phrases shall have the following meanings when used in this Contract.

A. "Aggregate Costs" means Operation and Maintenance Costs, Fixed Costs, and Underconsumption Costs, collectively, as defined herein.

B. "Alternate Delivery" means the delivery of Lake Water purchased by Montgomery from the Commission to the Montgomery Unit System through facilities owned by a Contract Customer (commonly referred to as "Wheeling").

C. "Asset-In-Kind Amount" means the differential amount, if any, that Montgomery pays for a portion of the increase in size of the primary 48" western pipeline (commencing at Book Road and 75th Street and extending west of the Fox River to a termination point at Orchard Road, also known as "TW 6/25" in the DWC naming convention) from the baseline pipe size to 54". The Commission and Montgomery will mutually agree in a separate document to be executed prior to the closing of the WIFIA Loan on the value of the contribution.

D. "Average Contract Customer Rate Per 1,000 Gallons" means Total Contract Customer Revenue divided by Total Contract Customer Use.

E. "Bond Ordinances" means all of the Commission's ordinances and resolutions under which the Commission has or will authorize the issuance of, or issue, Bonds.

F. "Bonds" means Revenue Bonds and Other Bonds.

G. "Capital Cost Recovery Charge" means the amount necessary, pursuant to Section 0.02 of the Water Commission Act of 1985 (as added by Public Act 093-0226) and Commission Resolution No. R-79-04, entitled "A Resolution Expressing the Policy of the DuPage Water Commission Regarding the New Subsequent Customer Pricing Methodology," to recover Montgomery's proportionate share of Original Capital Costs less Rebates, where Montgomery's proportionate share of Original Capital Costs less Rebates is that proportion of Original Capital Costs less Rebates which Montgomery's Full Water Requirements for 2022 and 2023 as reported by Montgomery to the IEPA bears to the sum of the Full Water Requirements or Minimum Take or Pay Requirements (as defined in the Contract Customer Contract), as applicable, of all of

the Commission's Contract Customers for such two years which the parties agree shall be \$9,998,815.00 based on the method of calculating such amount illustrated in Exhibit E attached to this Contract.

H. "Charter Customer Facilities" means all of the feeder mains, metering stations, and pressure adjusting stations constructed as of May 1, 1992, solely for the purpose of initially connecting the Charter Customers to the Waterworks System.

I. Intentionally Omitted.

J. "Charter Customers" means the units of local government (not including the Commission) that are parties to the Charter Customer Contract, excluding, however, any such unit of local government whose rights and obligations under such Contract have been terminated, including without limitation the Village of Montgomery.

K. "Commission" means the DuPage Water Commission, DuPage, Cook, and Will Counties, State of Illinois.

L. "Commission Connection Facilities" means the portions of the Waterworks System constructed by the Commission to initially connect the WaterLink Communities including the Montgomery Unit System to the existing Waterworks System, which facilities are depicted in the preliminary plans attached as Exhibit B-2 to this Contract, as such facilities may be relocated, replaced, extended, or improved and may be used in the service of other customers from time to time. The Commission Connection Facilities include, among other items, metering station(s), including pipelines and equipment appurtenant thereto, and SCADA System facilities attributable to the Montgomery Unit System, including equipment appurtenant thereto.

M. “Connection Facilities” means the Montgomery Unit System Connection Facilities and the Commission Connection Facilities.

N. “Connection Facilities Cost” means the full actual cost incurred by the Commission in connection with (i) the design, bidding, contracting, managing, and actual construction, installation, removal, relocation, replacement, extension, or improvement of the Connection Facilities, including without limitation equipment required for the operation of the Connection Facilities and all administrative, financing, supervisory, inspection, engineering, surveying, and legal fees, costs, and expenses associated therewith; (ii) the acquisition and divestment of lands, easements, and rights of way over lands and waters necessary for the construction, installation, removal, relocation, replacement, extension, or improvement of the Connection Facilities, and all administrative, title, surveying, and legal fees, costs, and expenses associated therewith; and (iii) the review and processing of plans and agreements for the construction, installation, removal, relocation, replacement, extension, or improvement of the Connection Facilities and in connection with the negotiation, preparation, consideration, and review of this Contract, including without limitation all legal, engineering, consulting, and administrative fees, costs, and expenses associated therewith; except as any of the above are included in Operation and Maintenance Costs.

O. “Contract” means this Water Purchase and Sale Contract.

P. “Contract Customer Contract” means the Water Purchase and Sale Contract between the Commission and the Contract Customers dated as of January 18, 2024.

Q. "Contract Customers" collectively means the Contract Customers, Montgomery, and any other entity with whom the Commission has entered into, or may in the future enter into, a contract or agreement for the sale by the Commission of Lake Water to that entity, except only contracts and agreements providing for the delivery of Lake Water during times of emergency only.

R. "Days" means calendar days.

S. "Determination Date" means the last day of December immediately preceding the Interest Period for which the Earned Interest Rate pursuant to this Contract is being calculated, but the effective date of any change in the Earned Interest Rate shall, for purposes hereof, be the first day of May following such Determination Date.

T. "Earned Interest Rate" means, with respect to each Interest Period under this Contract, the highest monthly average yield to maturity interest rate earned by the Commission (total funds) as reported monthly on the Commission's Schedule of Investments for the immediate preceding fiscal year (May 1 – April 30) as determined by the Commission, which determination shall be conclusive and binding upon Montgomery absent manifest error, but the effective date of any change in the Earned Interest Rate shall, for purposes hereof, be the first day of May following such Determination Date.

U. "Fiscal Year" means the fiscal year of the Commission.

V. "Fixed Costs" means an amount sufficient at all times to pay the principal of and the premium, if any, and interest on any Revenue Bonds, to provide reserves required therefor, to provide an adequate depreciation fund for the Waterworks System, to

comply with the covenants of all Revenue Bond Ordinances, and to pay reasonable capital costs necessary to carry out the corporate purposes and powers of the Commission; except as any of the above are included in Operation and Maintenance Costs.

W. "Full Water Requirements" means, (i) as it applies to calculating Montgomery's Capital Cost Recovery Charge, the amount of water necessary to meet the potable water requirements of all then current customers served by the Montgomery Unit System at the time Montgomery's Capital Cost Recovery Charge is being calculated, (ii) as it applies to the Montgomery Unit System for all other purposes of this Contract, the amount of water necessary from time to time to meet the potable water requirements of all then current customers served by the Montgomery Unit System, and (iii) as it applies to other Contract Customers of the Commission, such Contract Customers' full water requirements as defined in their respective contracts with the Commission.

X. "Interest Period" means (i) initially, the period commencing on the first date on which Montgomery first becomes obligated to make payments under Subsection 7.D of this Contract and ending on the next succeeding first day of May and (ii) thereafter, each period commencing on the last day of the next preceding Interest Period and ending on the next succeeding first day of May; provided, however, that any Interest Period that otherwise extends beyond May 1, 2058, shall end on February 24, 2064.

Y. "Lake Water" means potable, filtered water drawn from Lake Michigan.

Z. "Operation and Maintenance Costs" means amounts payable by the Commission

under the Water Supply Contract, except Underconsumption Costs, and all expenses incurred in the administration, operation, and maintenance of the Waterworks System and the accumulation of reserves related to payment of said costs. Operation and Maintenance Costs in any month shall be at least equal to the amount required to be deposited by the Commission in that month into the operation and maintenance funds or accounts created under all Revenue Bond Ordinances.

AA. "Original Capital Costs" means all costs paid by the Commission for property owned by the Commission, as of April 30, 2024, without reduction for depreciation, including actual costs of construction, engineering, and capitalized interest on assets in service and under construction but excluding the cost of constructing the Charter Customer Facilities and financing costs other than interest capitalized in accordance with Generally Accepted Accounting Principles.

BB. "Original Revenue Bonds" means the Series 1987 Revenue Bonds, originally issued in the amount of \$200,000,000 pursuant to Ordinance No. 0-1-87 adopted January 15, 1987, and the Series 1993 Water Refunding Revenue Bonds, originally issued in the amount of \$182,755,000 pursuant to Ordinance No. 0-8-93 adopted April 8, 1993, and any other Revenue Bonds that may in the future be issued to refund or refinance all or any portion of the indebtedness represented by said Series 1987, 1993, 2003, and 2013 Revenue Bonds. As of the date of this Contract, all of the Original Revenue Bonds are fully paid and retired.

CC. "Montgomery" means the Village of Montgomery, located in Kane and Kendall Counties, State of Illinois.

DD. "Montgomery's Base Rate" means a water rate stated as dollars or cents per 1,000

gallons that is calculated by (i) the sum of all Operation and Maintenance Cost payments, all Fixed Costs payments, all Connection Facilities Cost payments, and all Capital Cost Recovery Charge payments under the Contract Customer Contract estimated to be made by Montgomery pursuant to this Contract in the Fiscal Year for which Montgomery's Base Rate pursuant to this Contract is being calculated and (ii) dividing the resulting amount by the total amount of Lake Water, stated in 1,000 gallon units, estimated to be delivered to Montgomery in said Fiscal Year.

EE. "Montgomery Unit System" means the waterworks system described in Exhibit A attached to this Contract as well as any extensions or improvements of that system acquired by Montgomery and used for the purpose of providing and transmitting water to its customers.

FF. "Montgomery Unit System Connection Facilities" means those portions of the Montgomery Unit System, lying downstream from the Point of Delivery, to be constructed pursuant to this Contract by Montgomery at its expense to initially connect the Montgomery Unit System to the Waterworks System, which facilities are depicted in the preliminary plans attached as Exhibit B-1 to this Contract, as such facilities may be relocated, replaced, extended, or improved from time to time. The Montgomery Unit System Connection Facilities include, among other items, the pressure adjusting station(s) described in Subsection 4.A of this Contract and pipeline and equipment appurtenant thereto.

GG. "Other Bond Ordinances" means all of the Commission's ordinances and resolutions under which the Commission has or may authorize the issuance of, or issue,

Other Bonds.

HH. "Other Bonds" means all of the Commission's debt obligations that are not Revenue Bonds, whether in the form of bonds, notes, or other evidence of indebtedness, in whatever original principal amount, together with any such additional non-revenue obligations authorized by statute to be issued by the Commission from time to time and refunding obligations issued to refund other such obligations.

II. "Point(s) of Delivery" means the point(s) at which the Lake Water delivered to Montgomery pursuant to this Contract leaves the Commission's Waterworks System and enters the Montgomery Unit System. A Point of Delivery shall be a point in the water main connecting the Commission's metering station(s) to Montgomery's pressure adjusting station(s) located downstream from the inside face of the outside wall or foundation of the Commission's metering station(s) a distance of 10 feet or where such water main enters the outside face of the outside wall or foundation of Montgomery's pressure adjusting station(s), whichever is closer to the Commission's metering station(s).

JJ. "Prime Rate" means the base corporate rate of interest then most recently announced by the largest commercial bank, measured in terms of total assets, located and doing banking business in the State of Illinois, which rate may or may not be said bank's lowest rate of interest charged by said bank for extensions of credit to debtors. The effective date of any change in the Prime Rate shall, for purposes hereof, be the effective date stated in the public announcement of said bank.

KK. "Rebates" means rebates formally declared as such by Commission Resolution as of the month prior to the month in which Montgomery first becomes obligated to

make payments under Subsection 7.D of this Contract. As of the date of this Contract, the Commission has formally declared \$106,326,287.00 in Rebates pursuant to Resolution Nos. R-19-94, R-21-95, R-15-96, R-24-97, R-18-98 and R-28-07.

LL. "Revenue Bond Ordinances" means all of the Commission's resolutions under which the Commission has or will authorize the issuance of, or issue, Revenue Bonds.

MM. "Revenue Bonds" means all of the Commission's debt obligations, including the Original Revenue Bonds, that are payable from the revenues of the Waterworks System, whether in the form of bonds, notes, or other evidence of indebtedness, in whatever original principal amount, together with any such additional revenue obligations authorized by statute to be issued by the Commission from time to time and refunding revenue obligations issued to refund other such obligations.

NN. "SCADA System" means the Supervisory Control and Data Acquisition System of the Commission that provides an integrated control, communication, and security system for the Waterworks System, including data processing, management, transfer, and exchange; central operation; system control and monitoring; and operator-machine interfacing.

OO. "Trustee" means a trustee provided in a Bond Ordinance.

PP. "Underconsumer" means, for any given year, a Contract Customer of the Commission that takes less Lake Water in such year than such Contract Customer's Water Allocation times 365 times the Underconsumption Ratio for such year.

QQ. "Underconsumption" means the amount by which the amount of Lake Water actually taken by a Contract Customer of the Commission is less than the Underconsumption Ratio times such Contract Customer's Water Allocation times 365.

RR. “Underconsumption Costs” means any amount that the Commission is obligated to pay under the Water Supply Contract solely by reason of failure to accept delivery of the minimum quantity of Lake Water that the Commission is obligated to purchase under the Water Supply Contract.

SS. “Underconsumption Ratio” means, for any given year, (i) the minimum amount of Lake Water required to be taken by the Commission under the Water Supply Contract divided by (ii) the sum of the Water Allocations of all Contract Customers of the Commission times 365.

TT. “Water Allocation” means, as it applies to other Contract Customers of the Commission, such Contract Customers’ water allocation as defined in their respective contracts with the Commission, and, as it applies to Montgomery, the sum of Montgomery’s allocations and allowable excesses from time to time of Lake Water for the Montgomery Unit System pursuant to the Level of Lake Michigan Act, as amended from time to time (See State of Illinois Department of Transportation, Division of Water Resources Decision on 1989 Allocation Review, Order No. LMO 89-2 and subsequent orders of the State of Illinois Department of Transportation, Division of Water Resources, or the successor to its responsibilities, the State of Illinois Department of Natural Resources, Office of Water Resources); and such other amounts of Lake Water as Montgomery may lawfully take for the Montgomery Unit System. At any time when the Full Water Requirements of the Montgomery Unit System shall exceed the Water Allocation for the Montgomery Unit System, then “Water Allocation” shall mean the Full Water Requirements of the Montgomery Unit System for all

purposes of this Contract.

UU. “Water Supply Contract” means the water supply contract, dated March 19, 1984, between the Commission and the City of Chicago, Illinois, as amended, supplemented, or extended from time to time, or any alternative water supply agreement, and most recently in 2024 and extends until 2041.

VV. “Waterworks System” means all the Commission’s facilities, including land; easements; rights-of-way over lands and waters; pumping facilities, storage facilities, metering stations, and other facilities; mains; and pipelines acquired and used for the purposes of providing and transmitting Lake Water from the Lake Michigan water supply system to the Commission’s customers. The Montgomery Unit System Connection Facilities are not part of the Waterworks System.

SECTION 3. WATER SUPPLY.

A. Agreement to Sell and Purchase. Subject to the provisions of this Contract, the Commission shall sell to Montgomery and Montgomery shall purchase from the Commission an amount of Lake Water necessary from time to time to serve the Montgomery Unit System’s Full Water Requirements. The Commission’s obligation to Montgomery to deliver Lake Water hereunder shall be limited, however, to a maximum annual amount equal to Montgomery’s then current Water Allocation times 365 and to a maximum rate of Lake Water to the Montgomery Unit System in any one hour equal to 1.7 times Montgomery’s then current Water Allocation divided by 24.

B. Beginning of Obligations to Deliver and Receive Lake Water. Unless this Contract is sooner terminated by the Commission pursuant to Subsection 20.B of this Contract, the Commission shall be obligated to deliver Lake Water to the Montgomery

Unit System and Montgomery shall be obligated to receive at the Montgomery Unit System Lake Water delivered by the Commission immediately after completion of construction of the Connection Facilities and the water storage capacity required pursuant to Subsection 4.B of this Contract; provided, however, that Montgomery shall have the right to receive Lake Water pursuant to this Contract prior to the completion of construction of the required storage capacity if such storage capacity has been substantially completed to the point where it is capable of serving its intended function or would be capable of serving its intended function except for the fact that painting or other finishing and restoration work are not complete.

C. Limits on Supply. The Commission shall use its best efforts to furnish Lake Water to Montgomery as hereinabove provided, but Montgomery acknowledges and agrees that the Commission's obligation hereunder is limited by:

- (i) The amount of Lake Water from time to time available to the Commission; and
- (ii) Provisions in contracts between the Commission and its Contract Customers and other customers related to curtailment and other limits on the supply of Lake Water; and
- (iii) The capacity of the Waterworks System; and
- (iv) Ordinary transmission loss, including standard metering error, between the Commission's source of supply and the Point of Delivery to the Montgomery Unit System; and
- (v) The other provisions of this Contract, including but not limited to Section 20.

D. Emergency or Maintenance Turn-Off. The Commission undertakes to use reasonable care and diligence to provide a constant supply of Lake Water as herein provided for but reserves the right at any time to turn off the flow of Lake Water in its

mains for emergency and maintenance purposes. The Commission shall give notice not less than 48 hours in advance of any turn-off for maintenance purposes and it shall give such notice as is reasonable under the particular circumstances of any turn-off for emergency purposes.

E. Curtailment; Emergency Use of Other Sources. If it becomes necessary for the Commission to limit its delivery of Lake Water to its customers for any reason, Montgomery shall be entitled, to the extent possible, to receive during such period of curtailment a pro rata share of available Lake Water as determined by the ratio of (i) the Montgomery Unit System's total Lake Water use during the prior Fiscal Year for other than start-up purposes pursuant to Subsection 10.I of this Contract to (ii) the sum of Lake Water use during the prior Fiscal Year of all of the Commission's customers entitled to Lake Water during such period of curtailment. Prior to the Commission's delivery of Lake Water to the Montgomery Unit System for a full Fiscal Year for other than start-up purposes pursuant to Subsection 10.I of this Contract, Montgomery shall be entitled, to the extent possible, to receive during such period of curtailment a pro rata share of available Lake Water as determined by the ratio of the Montgomery Unit System's Full Water Requirements during the prior Fiscal Year to the sum of (i) Lake Water use during the prior Fiscal Year of all of the Commission's other customers entitled to Lake Water during such period of curtailment and (ii) the Montgomery Unit System's Full Water Requirements during the prior Fiscal Year. Montgomery, in cases of emergency or when the Commission for whatever reason is unable to meet the Montgomery Unit System's Full Water Requirements, may, subject to the terms,

conditions, and limitations set forth in Subsection 9.N of this Contract, serve its customers from any source; provided, however, that Montgomery shall continue to pay all amounts due to the Commission hereunder during such period as if the Montgomery Unit System were receiving its Full Water Requirements from the Commission.

F. Water Quality. The Commission shall supply Montgomery with Lake Water of a quality commensurate to that furnished to the Commission's other Contract Customers, and meeting the requirements of any federal, State of Illinois, or local agency as shall have jurisdiction from time to time for the operation of public water supplies such as the Waterworks System. The Commission bears no responsibility for the contamination of Lake Water or deterioration of water quality occurring beyond the Points of Delivery to the Montgomery Unit System.

SECTION 4. DELIVERY; STORAGE.

A. Montgomery Unit System Connection Facilities. Montgomery shall receive its supply of Lake Water at the Montgomery Unit System Points of Delivery at pressures that will vary from time to time. Montgomery, at its own expense and pursuant to the schedule established in Section 10 of this Contract, shall site, design, construct, operate, maintain, and when necessary, replace the Montgomery Unit System Connection Facilities, including a pressure adjusting station immediately downstream from the Points of Delivery. Initial design and construction plans and specifications for the Montgomery Unit System Connection Facilities, and any future modifications thereof, shall be submitted in advance of construction or modification to the Commission for review and approval, which approval shall not be unreasonably

withheld. In the event the Montgomery Unit System or the Montgomery Unit System Connection Facilities are to be relocated, replaced, extended, or improved at the request of the Commission, its successor, other than those circumstances where the Commission is compelled to relocate the Montgomery Unit System or the Montgomery Unit System Connection Facilities for a non-Commission conflicting public infrastructure project or by State or Federal mandate, Montgomery will be entitled to reasonable and fair market value recovery for all costs without reduction for depreciation including actual costs of construction, engineering, and capitalized interest on assets in service and under construction and financing costs other than interest capitalized in accordance with Generally Accepted Accounting Principles.

B. Storage. Montgomery shall provide sufficient storage capacity within the Montgomery Unit System to store not less than two times the annual average daily water demand of the Montgomery Unit System; provided, however, that said requirement shall be reduced by (i) the amount of operable shallow well capacity (stated in gallons per hour) maintained by Montgomery in the Montgomery Unit System up to a maximum of 10 percent (10%) of said requirement plus (ii) an amount equal to the storage capacity maintained by the Commission in its Waterworks System multiplied by a fraction, the numerator of which is the annual average daily water demand of the Montgomery Unit System and the denominator of which is the total annual average daily water demands of all Contract Customers. The calculation of said water storage capacity requirement for the Montgomery Unit System is provided in Exhibit C attached to this Contract. In accordance with said requirement, Montgomery, at its own expense and pursuant to the schedule established in Section

10 of this Contract, shall construct for the Montgomery Unit System at least the amount of water storage capacity shown on Exhibit C to this Contract as the “Minimum Additional Required Storage.” Such water storage capacity shall be in addition to the amount of water storage capacity shown on Exhibit C to this Contract as the “Existing Storage” in the Montgomery Unit System. Montgomery shall properly maintain all such water storage capacity, including operable shallow well capacity, in good and serviceable condition. If at any time Montgomery’s water storage capacity in the Montgomery Unit System, including its allowances for operable shallow well capacity and Commission storage capacity as provided above, falls below 1.9 times the annual average daily water demand of the Montgomery Unit System, then Montgomery, within 24 months after such level of deficiency is reached, shall construct additional water storage capacity within the Montgomery Unit System of sufficient quantity to increase the total storage capacity of the Montgomery Unit System, including its allowances for operable shallow well capacity and Commission storage capacity as provided above, to not less than two times the annual average daily water demand of the Montgomery Unit System.

C. Metering of Shallow Wells. Montgomery shall furnish, install, and maintain a meter on each of its operable shallow wells. All such meters shall be of standard make and shall be subject to inspection and examination by any employee or agent of the Commission at all reasonable times. Montgomery shall calibrate all such meters at least once in each Fiscal Year. Montgomery shall notify the Commission of the time, date, and place of each calibration at least five days in advance thereof, and a representative of the Commission shall have the right to observe any adjustments

made to such meters in case any adjustments shall be necessary. The Commission shall have the right to place any or all of such meters under seal at any time.

D. Surges and Back-Flows. Montgomery's operation of its pressure adjusting station shall not cause surges or back-flows into the Waterworks System, nor shall the operation of the Montgomery's pressure adjusting station cause the Waterworks System pressure to drop below 20 pounds per square inch. The Commission shall not be responsible for any damage to the Montgomery Unit System or the Montgomery Unit System Connection Facilities caused by the design, operation, or maintenance of the Connection Facilities.

E. Maintenance of System; Water Quality; Prevention of Waste. Montgomery shall operate the Montgomery Unit System and the Montgomery Unit System Connection Facilities in such a manner as at no time to place the Commission and the Waterworks System in jeopardy of failing to meet the regulations of any agency or governmental authority having jurisdiction over the Commission's operation of its Waterworks System. The Commission and Montgomery shall notify each other immediately of all emergency and other conditions which may directly or indirectly affect the Waterworks System, the Montgomery Unit System, the Connection Facilities, or the quantity or quality of the Lake Water received pursuant to this Contract.

SECTION 5. MEASURING EQUIPMENT.

A. Metering Station and Instrumentation. The Commission shall, pursuant to the timetable established in Section 10 of this Contract, furnish, and install at the Points

of Delivery a metering station containing the necessary equipment and devices of a type meeting the standards of the American Water Works Association for measuring properly the quantity of Lake Water delivered under this Contract, including all structures as the Commission shall deem necessary to house such equipment and devices. Such furnishing and installing of a metering station shall be done in substantial conformance with the preliminary plans therefor attached as Exhibit B-2 to this Contract, as such preliminary plans may be revised by mutual agreement of the Commission and Montgomery. The Commission shall own, operate, maintain, and replace such metering station and all equipment and structures related thereto.

The metering station shall be located at a site or sites selected and acquired by Montgomery, and title transferred to the Commission, free and clear of all liens, claims, encumbrances, and restrictions unless otherwise approved by the Commission in writing. Montgomery shall be responsible for maintaining the grounds and landscaping, including but not limited to shrubbery and other plantings, located on each site provided. Such sites shall be subject to reasonable review and approval of the Commission, without charge to the Commission and pursuant to the timetable established in Section 10 of this Contract, shall grant to the Commission all necessary and insured easements for such site(s) and access thereto to the reasonable satisfaction of the Commission in a form similar to that attached as Exhibit D to this Contract and satisfactory to the Commission's attorneys. Montgomery also shall grant to the Commission all necessary and insured easements for the appropriate location and installation of antennas and appurtenant facilities for the Commission's SCADA

System attributable to the Montgomery Unit System on property owned by Montgomery or on property lying within the corporate limits of Montgomery, free and clear of all liens, claims, encumbrances, and restrictions unless otherwise approved by the Commission in writing. Such SCADA System antennas or facilities shall be installed on such easements in a manner that will reduce so far as reasonably possible any interference with the telemetry of the Montgomery Unit System.

Montgomery shall have access to the metering station for examination and inspection at reasonable times, but the reading for billing purposes, calibration, and adjustment of the equipment therein shall be done only by the employees or agents of the Commission.

B. Records. For the purpose of this Contract, the official record of readings of each meter at the metering station shall be the journal or other record book of the Commission in its office in which the records of the employees or agents of the Commission who take the readings are or may be transcribed. Upon written request of Montgomery, the Commission will give Montgomery a copy of such journal or record book, or permit Montgomery to have access thereto in the office of the Commission during regular business hours.

C. Calibration. At least once in each Fiscal Year, the Commission shall calibrate its meters dedicated to measuring the Lake Water delivered to the Montgomery Unit System, in the presence of a representative of Montgomery, and the Commission and Montgomery shall jointly observe any adjustments that are made to the meters in case any adjustments shall be necessary. If any check meters have been

installed, then such check meters shall be calibrated at least once in each Fiscal Year by Montgomery in the presence of a representative of the Commission, and the Commission and Montgomery shall jointly observe any adjustments that are made to the meters in case any adjustments shall be necessary.

D. Check Meters. Montgomery, at its option and its own expense, may install and operate a check meter to check each meter installed by the Commission, but the measurement of Lake Water for purposes of this Contract shall be solely by the Commission's meters, except in the cases hereinafter specifically provided to the contrary. All check meters shall be of standard make and shall be subject to inspection and examination by any employee or agent of the Commission at all reasonable times. The calibration and adjustment of check meters shall be made only by Montgomery, except during any period when a check meter may be used under the provisions hereunder for measuring the amount of Lake Water delivered to Montgomery, in which case the calibration and adjustment of such check meter shall be made by the Commission with like effects as if such check meter had been furnished and installed by the Commission.

E. Meter Malfunctions. If the Commission or Montgomery at any time observes a variation between a meter and a check meter or any evidence of meter malfunction, such party shall promptly notify the other party, and the Commission and Montgomery shall then cooperate to procure an immediate calibration test and such adjustment, replacement, or other work necessary to return such meter to accuracy. The party who discovers such variation or malfunction shall give the other party

written notice not less than 48 hours prior to the time of any test of any meter (which tests shall be conducted during normal working hours) so that the other party may conveniently have a representative present. If such representative is not present after the required notification at the time set in such notice, calibration and adjustment may proceed in the absence of said representative notwithstanding any other provision of this Subsection 5.E. If the percentage of inaccuracy of any meter is found to be in excess of two percent, registration thereof shall be corrected by agreement of the Commission and Montgomery based upon the best data available, for a period extending back to the time when such inaccuracy began if such time is ascertainable, or for a period extending back one-half of the time elapsed since the last date of calibration (but in no event further back than a period of six months) if such time is not ascertainable.

If for any reason any meter is out of service or out of repair so that the amount of Lake Water delivered cannot be ascertained or computed from the reading thereof, then the Lake Water delivered during the period such meter is out of service or out of repair shall be deemed to be the registration of the check meter if one has been installed and is registering accurately, or, in the event that no check meter has been installed or the check meter is registering inaccurately, shall be estimated:

- (i) By correcting the error if the percentage of the error is ascertainable by calibration tests or mathematical calculations; or
- (ii) If the error is not ascertainable by calibration tests or mathematical calculation, by estimating the quantity of delivery by considering deliveries during preceding periods under similar conditions when the meter or meters were registering accurately, adjusted for the addition of new customers to the Montgomery Unit System.

F. Removal of Metering Station and SCADA System Facilities. Within ninety (90) days after the termination of this Contract (absent a failure to renew), the Commission, at its own expense and in its discretion, may remove the metering station, including equipment, and the SCADA System antennas and appurtenant facilities from the property of Montgomery and release the perpetual easement therein. If the Commission fails to remove such station, equipment, and facilities, as aforesaid, Montgomery may take title to such station, equipment, and facilities.

SECTION 6. UNIT OF MEASUREMENT.

The unit of measurement for Lake Water delivered hereunder shall be gallons of water, U.S. Standard Liquid Measure, and all measuring devices shall be so calibrated unless the Commission and Montgomery otherwise agree. Should it become necessary or desirable to use other units of measurement, the basis of conversion shall be that 7.48 gallons is equivalent to one cubic foot.

SECTION 7. PRICES AND TERMS OF PAYMENT.

A. Operation and Maintenance Costs Payment. Montgomery shall pay monthly to the Commission, at the time specified in Subsections 7.G and 7.M below, a share of the Commission's Operation and Maintenance Costs for each month, which shall be an amount equal to the then current price per 1,000 gallons for Operation and Maintenance Costs times the quantity of Lake Water divided by 1,000 delivered by the Waterworks System to the Montgomery Unit System for such month. At any time after the commencement of Lake Water delivery, no Lake Water is being supplied through the Waterworks System to any Contract Customer, Montgomery's share of

monthly Operation and Maintenance Costs for the Montgomery Unit System shall be that proportion of those costs which the Montgomery Unit System's Water Allocation bears to the total Water Allocations of all of the Commission's customers required to make Operation and Maintenance Costs payments during the same period.

B. Fixed Costs Payment. Subject to the single limitation on its obligation to pay Fixed Costs set forth in this Subsection 7.B, Montgomery shall pay monthly to the Commission, at the time specified in Subsections 7.G and 7.M below, one-twelfth of the Montgomery Unit System's share of Fixed Costs for each Fiscal Year. However, as of the date of this Contract, the Fixed Costs are \$0 per month. For the purposes of this Contract, the Montgomery Unit System's share of Fixed Costs for each Fiscal Year shall be that proportion of Fixed Costs which the Montgomery Unit System's Full Water Requirements for the two preceding calendar years prior to such Fiscal Year bears to the sum of the Full Water Requirements or Minimum Take or Pay Requirements, as applicable, of all of the Commission's Contract Customers for such two preceding calendar years who are not relieved from Fixed Costs payments pursuant to the terms of their contracts. Prior to the Commission's delivery of Lake Water to the Montgomery Unit System for two calendar years for other than start-up purposes pursuant to Subsection 10.I of this Contract, the Montgomery Unit System's share of Fixed Costs shall be that portion of Fixed Costs which the Montgomery Unit System's Water Allocation bears to the total Water Allocations or the Full Water Requirements or Minimum Take or Pay Requirements, whichever is then applicable, of all of the Commission's Contract Customers who are not relieved from Fixed Costs payments pursuant to the terms of their contracts. Subject to the following single

limitation, Montgomery's obligation to make all payments of Fixed Costs as required hereunder is unconditional and irrevocable, payable without setoff or counterclaim, and irrespective of whether Lake Water is ever furnished, made available, or delivered to the Montgomery Unit System, or whether the Waterworks System is completed, operable, or operating, and notwithstanding suspension, interruption, interference, reduction, or curtailment of the supply of Lake Water. Montgomery's obligation to pay Fixed Costs hereunder is subject to the single limitation that, if for any period of time, and only during such period of time, the Commission is in fact supplying the Full Water Requirements or Minimum Take or Pay Requirements, as applicable, to Contract Customers of the Commission, other than Montgomery, whose Full Water Requirements and Minimum Take or Pay Requirements are more than 85 percent of the sum of the Full Water Requirements or Minimum Take or Pay Requirements, as applicable, of all Contract Customers of the Commission, and during such time the Commission is unable to supply any Lake Water to the Montgomery Unit System, then Montgomery shall have no obligation to pay Fixed Costs for the Montgomery Unit System. However, as of the date of this Contract, the Capital Recovery Cost Credit is \$0 because Fixed Costs are currently \$0.

C. Connection Facilities Cost Payment. Montgomery shall pay to the Commission its share of the Connection Facilities Cost in accordance with the WaterLink Communities Intergovernmental Cost Share Agreement, wherein Montgomery commits and agrees to pay 24.42% of the total Connection Facilities Cost. The Commission is not a party to the WaterLink Communities' Intergovernmental Cost-Share Agreement and has no responsibility or liability as to

any true-up or adjusted accounting between the WaterLink Communities. Contemporaneously and pursuant to this Contract, Montgomery and the Commission shall enter into an WaterLink Project Escrow Intergovernmental Agreement with the Village of Montgomery (the “Escrow IGA”) substantially in the form attached hereto as Exhibit G. In the event a line of credit issued by the Commission to Montgomery and any of the WaterLink Communities for Connection Facilities Costs the total line of credit amount provided to the WaterLink Communities shall not exceed Twenty-one Million Dollars (\$21,000,000) (the “Commitment Amount”). Montgomery’s obligation to make its share of the payment for the Connection Facilities Cost as required in and under the Escrow IGA is unconditional and irrevocable, and may be payable without setoff or counterclaim, and irrespective of whether Lake Water is ever furnished, made available, or delivered to Montgomery, or whether the Waterworks System is completed, operable, or operating, and notwithstanding suspension, interruption, interference, reduction, or curtailment of the supply of Lake Water.

D. Capital Cost Recovery Charge Payment. Montgomery shall pay monthly to the Commission, at the time specified in Subsections 7.G and 7.M below, an amount calculated by amortizing the Capital Cost Recovery Charge (less any Asset-in-Kind Amount), in equal monthly installments of principal and interest, at a rate per annum equal to the Earned Interest Rate determined for each Interest Period plus one percent, over the life of the Contract Customer Contract remaining as of the month in which Montgomery first becomes obligated to make such payment; provided, however, that such monthly installment may be adjusted by the Commission, on May 1 of each year thereafter, to ensure amortization of the then-current amount of the Capital Cost

Recovery Charge (less any Asset-in-Kind Amount) remaining unpaid, as of such May 1, over the life of the Contract Customer Contract then remaining, and to reflect any change in the Earned Interest Rate, as of such May 1. The method of calculating the Capital Cost Recovery Charge is illustrated in Exhibit E attached to this Contract. Montgomery's obligation to make all Capital Cost Recovery Charge payments as required hereunder is unconditional and irrevocable, payable without setoff or counterclaim, and irrespective of whether Lake Water is ever furnished, made available, or delivered to Montgomery, or whether the Waterworks System is completed, operable, or operating, and notwithstanding suspension, interruption, interference, reduction, or curtailment of the supply of Lake Water.

E. Underconsumption Costs Payment. If Montgomery is an Underconsumer at the Montgomery Unit System, then Montgomery shall pay, at the time specified in Subsections 7.G and 7.M below, its share of Underconsumption Costs as determined and assessed by the Commission after notification of such costs under the Water Supply Contract. In such event, Montgomery's share of Underconsumption Costs for the Montgomery Unit System for a year shall be equal to the ratio of its Underconsumption to the aggregate Underconsumption of all Underconsumers for such year.

F. Default Shares. If any of the Commission's Contract Customers shall default in any payment to the Commission, or any part of any payment, including default shares, Montgomery agrees to pay to the Commission a share of the amount so in default, which share shall be in the same proportion as the Montgomery Unit

System's share of Aggregate Costs for the month prior to the month of the default bears to the sum of the shares of Aggregate Costs in that month of all of the Commission's Contract Customers not in default and obligated to make payments with respect to the amount so in default.

Subject to Subsection 7.M below, Montgomery's share of the amount so in default shall be due and payable 21 days after the Commission's written demand therefor. The demand shall include the Commission's calculations of the amount due by Montgomery hereunder. If and when the defaulting customer makes a payment to the Commission of a defaulted amount or interest thereon for which Montgomery made a payment to the Commission under this Subsection 7.F, then the Commission will pay to Montgomery its proportionate share of such amount, including such interest.

G. Bills and Due Date. Except with respect to the payment of the Possible Shortfall required pursuant to Subsection 7.C above and the payment of default shares pursuant to Subsection 7.F above, the Commission shall notify Montgomery of the total amount due under this Contract for each month on or before the 10th day of the following month. Montgomery's costs for each month shall be due and payable and must be received at the offices of the Commission, on or before the 10th day of the month following the month of the Commission's notification or within 28 days after the date of notification, whichever is later.

H. Disputed Payments. If Montgomery desires to dispute any payment, or part thereof, due or reasonably claimed by the Commission to be due under this Contract, Montgomery shall nevertheless pay the full amount of any such payment when due

and include with such payment written notification to the Commission that charges are disputed, the grounds for dispute, and the amount in dispute. No adjustment or relief on account of any disputed charges shall be made unless disputed charges are the subject of such notice within the time herein specified, or within a reasonable period from the time Montgomery knew or should have known of the facts giving rise to the dispute.

Upon receipt of a notification of dispute, representatives of the Commission shall meet promptly with representatives of Montgomery to resolve such dispute. No adjustment or relief on account of any disputed charges shall be made unless disputed charges are the subject of such notice within twenty-one (21) days of receipt by Montgomery of the bill, or within a reasonable period from the time Montgomery knew or should have known of the facts giving rise to the dispute.

If the Commission and Montgomery determine that all or a portion of the disputed payment should be refunded to Montgomery, then such sum shall be refunded with interest thereon at the rate established in Subsection 7.I below from the date such disputed payment was made.

I. Interest on Overdue Payments. If Montgomery shall fail to make any payment required under this Contract, the Escrow IGA, or the Capital Cost Recovery Charge IGA to the Village of Montgomery on or before its due date, Montgomery shall be in default, and interest on the amount of such payment shall accrue to the extent permitted by law, and be compounded on a monthly basis, during the period of non-payment at the higher of:

(i) the weighted average effective interest rate on all series of Bonds of the Commission any of which are then outstanding plus two percent; or

(ii) the Prime Rate plus five percent.

Such interest shall accrue from the date such payment becomes due until paid in full with interest as herein specified. If such payment is not made by Montgomery within 30 days after the date such payment becomes due, then the Commission, at its option and in its discretion, may reduce or discontinue delivery of Lake Water to the Montgomery Unit System until the amount due the Commission is paid in full with interest as herein specified. The Commission shall give notice to Montgomery not less than 20 days prior to the event of its intention to reduce or discontinue delivery of Lake Water in accordance with this Subsection 7.I and shall provide Montgomery an opportunity for a hearing before the Commission prior to any reduction or discontinuance. If the Commission reduces or discontinues the delivery of Lake Water under such circumstances, Montgomery shall nevertheless continue to be liable to pay all charges provided for herein as if the Montgomery Unit System were receiving its Full Water Requirements from the Commission. The rights specified in this Subsection 7.I shall be in addition to all other rights and remedies available to the Commission under this Contract, at law, or in equity for breach of any of the provisions of this Contract.

J. Security Deposit. If Montgomery is at any time in default on any payment due under this Contract, the Escrow IGA, or the Capital Cost Recovery Charge IGA, and the default is not cured within 30 days after the due date of the defaulted payment,

then the Commission, at its option and in its discretion, may require Montgomery, as a further obligation under this Contract, to deposit in a separate account in the Commission's name a sum of money as security for the payment of Montgomery's obligations hereunder of a reasonable amount determined by the Commission. Montgomery's compliance with the Commission's demand for such a security deposit shall be a condition precedent to the curing of such Montgomery default and the restoration of the Lake Water service to the Montgomery Unit System if such Lake Water service has been reduced or discontinued by reason of such default. The security deposit or any part thereof may be applied, at the Commission's option and in its discretion, to any subsequent default by Montgomery in any payments due under this Contract, the Escrow IGA or the Capital Cost Recovery Charge IGA. If so applied, Montgomery shall provide funds within 10 days to restore the security deposit to the amount required by the Commission. At the earliest of the end of the term of this Contract, or a term of two years after the curing of the most recent default by Montgomery, or such earlier time that the Commission at its option and in its discretion may determine, any security deposit shall be returned to Montgomery if Montgomery has performed all its obligations under this Contract, the Escrow IGA or the Capital Cost Recovery Charge IGA. Montgomery shall not be entitled to receive any interest on any security deposit.

K. Prepayments. Subject to the limitations of this paragraph, Montgomery may (i) at any time, and from time to time, before Montgomery first becomes obligated to make payments of Operation and Maintenance Costs pursuant to Subsection 7.M

below, and (ii) no more frequently than once in any given year thereafter, at any time during the month of December, prepay, in whole or in part, the Connection Facilities Cost, the Capital Cost Recovery Charge Amount due, or other amount previously agreed to, pursuant to this Contract, without premium or penalty, upon at least one business day's irrevocable notice to the Commission, specifying the date and amount of prepayment. If such notice is given, Montgomery shall make such prepayment and the payment amount specified in such notice shall be due and payable on the date specified therein. The proceeds of any such prepayment shall be applied by the Commission first, to the payment of accrued and unpaid interest, if any, on the Connection Facilities Cost accruing after the date specified in Subsection 7.M below; second, to the payment of the unpaid principal balance of the Connection Facilities Cost; third, to the payment of accrued and unpaid interest, if any, on the Capital Cost Recovery Charge Amount accruing after the date specified in Subsection 7.M below; and fourth, to the payment of the unpaid principal balance of the Capital Cost Recovery Charge Amount; provided, however, that Montgomery shall not be entitled to make any such prepayment pursuant to this paragraph if Montgomery's Base Rate during the Fiscal Year next following the date of such payment would be, as estimated by the Commission, less than the Average Contract Customer Rate Per 1,000 Gallons. For purposes of calculating Montgomery's Base Rate, any such prepayment shall be deemed to have been paid effective as of the 30th day of April next following the date of such payment or the 30th day of April next following the month in which Montgomery first becomes obligated to make such Connection Facilities Cost

payments and Capital Cost Recovery Charge Amount payments, whichever is later. Montgomery shall not be entitled to, nor receive any credit for, interest on any such prepayment.

Notwithstanding anything to the contrary contained herein, in the event the Montgomery Unit System has not been constructed, installed, and completed, to a point where it is capable of serving its intended function at the time Montgomery first becomes obligated to make payments of Operation and Maintenance Costs pursuant to Subsection 7.M below, then the Commission may, in its sole and absolute discretion, declare the principal amount of the Connection Facilities Cost remaining unpaid, in whole or in part, the principal amount of the Capital Cost Recovery Charge remaining unpaid, in whole or in part, or both of such remaining unpaid costs, in whole or in part, due and payable within 30 days following the date of such declaration, together with accrued and unpaid interest as herein specified on such declared due amounts to the date paid, unless the Commission shall have exercised its right to terminate this Contract pursuant to Subsection 20.C of this Contract. The rights specified in this paragraph shall be in addition to all other rights and remedies available to the Commission under this Contract, at law, or in equity for breach of any of the provisions of this Contract.

L. Enforcement of Provisions Hereof by Other Customers. Montgomery acknowledges that its obligation to make payments pursuant to the terms of this Section 7 is of benefit to the Commission's Contract Customers, Bondholders, and any Trustee. Accordingly, Montgomery agrees that, in addition to the Commission, Bondholders, a

Trustee or other parties allowed by law are entitled to enforce the provisions of this Contract. Further, any three or more of the Commission's Contract Customers acting together may enforce the provisions of this Section 7, but only if the Commission has not acted to enforce such provisions within 90 days after any failure by Montgomery to make a payment hereunder.

M. Beginning of Obligation to Pay. Notwithstanding any other provision of this Contract, the obligation to make any and all payments under this Contract, except only payments of Operation and Maintenance Costs pursuant to Subsection 7.A above and payment of any Possible Shortfall required pursuant to Subsection 7.C above, shall begin on the Commission's first regular billing cycle after the earlier to occur of (i) the first delivery of Lake Water to the Montgomery Unit System or any portion thereof or (ii) 12 months following completion of construction of the Commission Connection Facilities, other than the SCADA System facilities, to the point where they are capable of serving their intended function or would be capable of serving their intended function except for the fact that the Montgomery Unit System Connection Facilities are not complete. The obligation to make payments of Operation and Maintenance Costs pursuant to Subsection 7.A above shall begin on the Commission's first regular billing cycle after the earlier to occur of (i) the first delivery of Lake Water to the Montgomery Unit System or any portion thereof or (ii) completion of construction of the Commission Connection Facilities, other than the SCADA System Facilities, to the point where they are capable of serving their intended function or would be capable of serving their intended function except for the fact that the Montgomery Unit System Connection Facilities are not complete. At any time prior to the first delivery of Lake

Water to the Montgomery Unit System when Montgomery is obligated to make payments pursuant to this Subsection 7.M, such payments shall be based on the Full Water Requirements of the Montgomery Unit System.

SECTION 8. SPECIAL CONDITIONS AND COVENANTS.

A. Construction of the Commission Connection Facilities; No Delay Damages; Supply of Lake Water. The Commission will make a diligent effort to have the Commission Connection Facilities completed to the Points of Delivery so as to furnish Lake Water to the Montgomery Unit System by the date specified in Subsection 10.H of this Contract, but the Commission does not in any way guaranty delivery by such date.

Montgomery acknowledges and agrees that the Commission shall not be liable to Montgomery for any damages occasioned by or in any way related to delay in the delivery of Lake Water to the Montgomery Unit System, and all payments from Montgomery provided for under this Contract shall remain due and payable in accordance with the terms of this Contract notwithstanding any such delay.

After Lake Water is first tendered for delivery to the Montgomery Unit System at the Points of Delivery for other than start-up purposes pursuant to Subsection 10.I of this Contract, the Commission, subject to the other terms and conditions of this Contract, shall use its best efforts to continually hold itself ready, willing, and able to supply Lake Water to the Montgomery Unit System at such Points of Delivery. The Commission also shall use its best efforts, consistent with its prior obligations and legal obligations to its customers and consistent with the fair and equitable treatment of all

of its Contract Customers, to supply the Montgomery Unit System with such additional amounts of Lake Water as from time to time may be allocated to the Montgomery Unit System over and above the Montgomery Unit System's present Water Allocation; provided, however, that the Commission does not in any way guaranty a supply of such additional amounts.

B. Lake Water Only; Costs. Except with the prior approval of Montgomery, the Commission shall not deliver any water to the Montgomery Unit System other than Lake Water. Except for Lake Water supplied for start-up purposes pursuant to Subsection 10.I of this Contract, costs for Lake Water charged to Montgomery by the Commission pursuant to this Contract shall include only the costs set forth in Section 7 of this Contract.

C. Title to Lake Water. Title to all Lake Water supplied hereunder shall remain in the Commission to the Points of Delivery and thereupon shall pass to Montgomery.

D. Emergency Supply. Subject to the terms, conditions, and limitations set forth in Subsection 9.N of this Contract, Montgomery may contract for a temporary supply of water in case of an emergency from any unit of local government or any other entity. Montgomery shall notify the Commission and shall promptly provide the Commission with copies of all such contracts.

E. Covenants to Be Set Out in Bond Ordinance. Montgomery acknowledges the existence, and its understanding of the provisions, of certain Bond Ordinances pursuant to which the Commission has previously issued its Bonds. Montgomery

further acknowledges and agrees that said Bond Ordinances grant to Bondholders certain rights to enforce certain duties of the Commission and its customers, including those with respect to the making of rates and charges and the collection of revenues, and that such Bondholder rights may be included in any subsequent Bond Ordinances.

F. Payments Hereunder are an Operational Expense of the Montgomery Unit System. Montgomery agrees that, to the fullest extent permitted by law or contract, all payments to be made by Montgomery pursuant to this Contract shall constitute operating expenses of the Montgomery Unit System as to any and all revenue bonds of Montgomery which are supported in whole or in part by a pledge of the revenues of the Montgomery Unit System, with the effect that Montgomery's obligation to make payments from its water revenues under this Contract has priority over its obligation to make payments of the principal and of the premium, if any, and interest on any such bonds which are or will be supported in whole or in part by a pledge of any Montgomery Unit System revenues. Montgomery shall make all budgetary, emergency, and other provisions and appropriations necessary to provide for and authorize the prompt payment to the Commission of all rates and charges under this Contract. The obligations of Montgomery under this Contract are further payable from all other accounts of the Montgomery Unit System in which there are lawful available funds. In any revenue bond or indenture hereafter issued by Montgomery, the priority of lien established pursuant to this Contract shall be expressly provided and set forth in said bond ordinances or resolutions. Notwithstanding the foregoing, however, Montgomery's obligations under the IEPA Loans referenced in Subsection 9.D to be

secured in whole or in part by a pledge of Montgomery Unit System revenues to the IEPA shall have priority of lien over Montgomery's obligation to make payment from its water revenues under this Contract.

SECTION 9. ADDITIONAL MONTGOMERY COVENANTS.

A. Maintenance of Corporate Existence. Montgomery agrees that during the term of this Contract it will maintain its municipal corporate existence, it will continue to be a municipal corporation in good standing in the State of Illinois, it will not dissolve or otherwise dispose of all or substantially all of the assets of the Montgomery Unit System.

B. Maintenance and Operation of Montgomery Unit System. Montgomery shall own and maintain the Montgomery Unit System and the Montgomery Unit System Connection Facilities, and all improvements and extensions of the Montgomery Unit System and the Montgomery Unit System Connection Facilities, in good repair and working order, will operate the Montgomery Unit System and the Montgomery Unit System Connection Facilities efficiently, and will punctually perform all duties with respect to the Montgomery Unit System and the Montgomery Unit System Connection Facilities as may be required by this Contract, and by the Constitution and laws of the State of Illinois and all other applicable laws. In the event of any deterioration, injury, damage, or other loss to the Montgomery Unit System or the Montgomery Unit System Connection Facilities affecting Montgomery's ability to deliver water to any of Montgomery's customers, Montgomery shall promptly restore the Montgomery Unit System or the Montgomery Unit System Connection Facilities

and their capacity to so deliver water.

C. Rate Covenant. Montgomery shall take all necessary actions to establish, maintain, revise as necessary, and collect rates and charges for customers of the Montgomery Unit System as shall be required from time to time to produce revenues at least sufficient:

(i) To pay all amounts due under this Contract, the Escrow IGA, the Capital Cost Recovery Charge IGA and the IEPA Loans referenced herein, and to pay all other costs of operation and maintenance of the Montgomery Unit System and the Montgomery Unit System Connection Facilities; and

(ii) To provide an adequate depreciation fund for the Montgomery Unit System and the Montgomery Unit System Connection Facilities; and

(iii) To make all deposits in all funds and accounts required by the terms of resolutions or ordinances authorizing any obligation of Montgomery payable from the revenues of the Montgomery Unit System; and

(iv) To pay the principal of and the premium, if any, and interest on all obligations of Montgomery payable from the revenues of the Montgomery Unit System including, but not limited to, its obligations under the Escrow IGA, the Capital Cost Recovery Charge IGA, and to repay the IEPA Loans referenced in Subsection 9.D.

D. Future Subordination of Obligations. Any ordinance, resolution, motion, or other action of Montgomery which authorizes the issuance after the date of this Contract of any obligation of Montgomery to be paid from the revenues of the Montgomery Unit System will expressly provide that revenues of said System may be used to pay principal of, and the premium, if any, and the interest on such obligations only to the extent that those revenues exceed the amounts required to pay the operation and maintenance expenses of said System including, expressly, all amounts payable

from time to time under this Contract, except for any present or future ordinance, resolution, motion or other action of Montgomery which authorizes, or has authorized, it to borrow funds from and enter a loan agreement with the Illinois Environmental Protection Agency (the "IEPA Loans") which may provide for the collection, segregation, distribution and/or pledge of revenues of the Montgomery Unit System which shall be the only obligation with preference of priority over Montgomery's obligation to the Commission hereunder.

E. General Covenant to Operate Properly. From time to time, Montgomery shall take all steps reasonably necessary so that the Montgomery Unit System and the Montgomery Unit System Connection Facilities may at all times be operated in accordance with industry standards.

F. Accounting and Audit. Montgomery shall make and keep proper books and accounts (separate and apart from all other records and accounts of Montgomery) in which complete entries shall be made of all transactions relating to the Montgomery Unit System, and, within 180 days after the close of each of its fiscal years occurring during the term of this Contract, Montgomery shall cause the books and accounts of the Montgomery Unit System to be audited annually by independent certified public accountants, showing the receipts and disbursements on account of the Montgomery Unit System.

G. Maintain Ownership of Montgomery Unit System. Montgomery shall construct to completion and thereafter continue to own and possess the Montgomery Unit System and, within the exercise of reasonable business judgment and in a manner

so as not to cause a default hereunder, shall dispose of property which is part of said System only to the extent that the Commission consents in writing, which consent shall not be unreasonably withheld. This subsection G does not prohibit Montgomery from selling specific equipment that it considers surplus and that is no longer needed or utilized to operate the Montgomery Unit System.

H. Insurance. Montgomery shall carry insurance or maintain self-insurance with respect to the Montgomery Unit System and the Montgomery Unit System Connection Facilities of the kinds and in the amounts that are customarily carried or maintained by parties operating similar properties, including, without limiting the generality of the foregoing, fire and other casualty and liability insurance or protection. All moneys received for loss under the insurance policies or on deposit as self-insurance reserves shall be used in making good the loss or damage in respect of which they were paid, whether by repairing the property damaged or replacing the property destroyed, and provision for making good such loss or damage or replacing the property destroyed shall be made within a reasonable time from date of loss. The proceeds derived from any and all policies or available from self-insurance reserves for public liability losses shall be used in paying or reimbursing any accounts from which payments for settlements, judgments, or expenses were advanced.

I. Continue to Serve. Montgomery shall use its best efforts to continue serving all customers of the Montgomery Unit System within its territorial limits that are intended to be served by the Montgomery Unit System as of the date of this Contract.

J. Maintain Water Allocation. Montgomery shall use its best efforts to obtain

or retain, from time to time, a Water Allocation for the Montgomery Unit System at least equal to, but not in excess of two times, the Montgomery Unit System's Full Water Requirements from time to time.

K. Release and Indemnification. To the fullest extent permitted by law, Montgomery hereby releases the Commission from, agrees that the Commission shall not be liable for, and agrees to indemnify and hold the Commission harmless from: (1) any liabilities for any loss or damage to property or any injury to, or death of, any person that may be occasioned by or related to any cause whatsoever pertaining to the construction, installation, removal, relocation, replacement, extension, improvement, maintenance, or operation of the Montgomery Unit System or the Connection Facilities or (2) any liabilities, losses, or damages, or claims therefor, arising out of the failure, or claimed failure, of Montgomery to comply with its covenants or obligations contained in this Contract, including, in each such case, any attorneys' fees. Montgomery agrees to indemnify and hold the Commission harmless to the fullest extent permitted by law from any losses, costs, charges, expenses (including attorneys' fees), judgments, and liabilities incurred by the Commission in connection with any action, suit, or proceeding instituted or threatened by any third party in connection with this Contract. If any such claim is asserted, the Commission shall give prompt notice to Montgomery and Montgomery, if requested by the Commission, shall assume the defense thereof, it being understood, however, that Montgomery shall not settle or consent to the settlement of any such claim without the written consent of the Commission.

L. Combining or Separating System Accounts. Montgomery shall not

combine its waterworks system with its sewerage system or separate its combined waterworks and sewerage system into separate systems unless:

(i) Montgomery shall have provided the Commission with written evidence, satisfactory to the Commission, that the proposed combination or separation will not materially or adversely affect Montgomery's ability to comply with all of the terms, conditions, and covenants of this Contract; and

(ii) The Commission shall have approved such combination or separation in writing.

M. Rate of Withdrawal. Montgomery will take Lake Water at the most uniform and continuous rate of withdrawal practical.

N. Emergency Interconnections. No emergency interconnection between the Montgomery Unit System and a water distribution system owned and operated by another Contract Customer ("Emergency Interconnection") shall be constructed, operated, or maintained except in accordance with the following terms, conditions, and limitations:

(i) The other Contract Customer and Montgomery shall submit to the Commission, for its review and approval, at least 60 days prior to the construction of the Emergency Interconnection or, if the Emergency Interconnection was constructed prior to the execution of this Contract, within 60 days following the execution of this Contract, a report detailing the exact location of the Emergency Interconnection, the manner in which the Emergency Interconnection has been and will be operated and maintained, and the terms of any written or oral agreement for the operation and maintenance of the Emergency Interconnection. Such report shall include as-built drawings of the Emergency Interconnection and exact duplicates of any written agreement for the operation and maintenance of the Emergency Interconnection. The Emergency Interconnection shall not be operated unless and until the Commission shall have approved such report and the Commission shall have received and approved the written agreements required pursuant to clauses (ix) and (xii) of this Subsection 9.N. No approval of such report shall be withheld unless the Emergency Interconnection, or any agreement for the

operation and maintenance of the Emergency Interconnection, violate the Contract Customer Contract, this Contract, the Water Supply Contract, or applicable laws or regulations, or pose a threat to the Commission or its Waterworks System.

(ii) The Emergency Interconnection shall be utilized only under emergency conditions unless otherwise approved, in writing, by the Commission. An emergency condition shall be defined to mean the inability to provide average day flow demands to regular, non-emergency supply customers during a limited period of time due to conditions beyond the control of the party requesting Lake Water. An emergency condition shall not mean any limitation imposed by the Commission on the supply of Lake Water to the other Contract Customer or Montgomery specifically related to the other Contract Customer or Montgomery pursuant to Section 3 of this Contract or any similar provision of any other water purchase and sale contract, as the case may be, and the Emergency Interconnection shall not be utilized to circumvent the provisions of any agreement approved by the Commission for the Alternate Delivery of Lake Water.

(iii) The Emergency Interconnection shall be maintained in such a manner as at no time to place or threaten to place the Commission or its Waterworks System in jeopardy of failing to meet the terms of the Contract Customer Contract, this Contract, the Water Supply Contract, or the regulations of any agency or governmental authority having jurisdiction over the of a public water supply.

(iv) The party experiencing the emergency condition shall give telephonic notice to the Commission and to the other party of the emergency condition, the expected duration of the emergency condition, and the amount of Lake Water needed, prior to the operation of the Emergency Interconnection. The Emergency Interconnection shall not be operated unless and until the party experiencing the emergency condition shall have given said notice to the Commission.

(v) The party receiving Lake Water through the Emergency Interconnection shall provide daily telephonic notice to the Commission and the party delivering Lake Water for so long as the emergency deliveries continue, and shall provide telephonic notice to the Commission before final shut-off of the emergency flow of Lake Water through the Emergency Interconnection for each such emergency condition.

(vi) The other Contract Customer and Montgomery shall keep a joint record of the amount of Lake Water delivered through the Emergency Interconnection, a copy of which shall be provided to the Commission within five days following termination of the use of the Emergency Interconnection for each such emergency condition and, in any case, every five days where the Emergency Interconnection is continuous for more five days.

(vii) The amount of Lake Water delivered to the other Contract Customer's water distribution system or to the Montgomery Unit System through the Emergency Interconnection, as the case may be, shall be paid to the Commission directly by the party receiving Lake Water through the Emergency Interconnection at the rates applicable pursuant to, and in accordance with, that party's water purchase and sale contract with the Commission. In case of service curtailment, the other Contract Customer's flow of water through the Emergency Interconnection shall be considered as a portion of the other Contract Customer's allocation from the Commission. In case of service curtailment, Montgomery's flow of water through the Emergency Interconnection shall be considered as a portion of Montgomery's allocation from the Commission.

(viii) The Commission shall have the right to inspect the Emergency Interconnection, and its operation and maintenance. The Commission shall have the right to install seals or such other devices as the Commission, in its sole and absolute discretion, determines are necessary to determine the operation of the Emergency Interconnection, and all equipment required to be installed to allow the installation of the seals or such other devices shall be installed at Montgomery's sole cost and expense.

(ix) The Commission shall bear no responsibility for, and the other Contract Customer and Montgomery shall, in writing, release the Commission from, and agree, to the fullest extent permitted by law, that the Commission shall not be liable for, and agree to indemnify and hold the Commission harmless from, any claims, damages, liabilities, and litigation that may be occasioned by, connected with, or in any way related to the construction, operation, and maintenance of the Emergency Interconnection. The other Contract Customer and Montgomery shall agree, in writing, to pay all fees, costs, and expenses, including legal and administrative fees, costs, and expenses, incurred by the Commission in defending itself with regard to any and all of the matters mentioned in this Subsection 9.N.

(x) The operation and maintenance of the Emergency Interconnection

shall comply in all other respects with the Water Commission Act of 1985, the Contract Customer Contract, this Contract and the Water Supply Contract and the requirements of the Commission thereunder.

(xi) Notwithstanding anything to the contrary contained in any written or oral agreement for the operation and maintenance of the Emergency Interconnection, the Emergency Interconnection shall be operated and maintained only in accordance with this Subsection 9.N and such additional or other terms, conditions, and limitations as the Commission shall impose pursuant to any policy established by the Commission with respect to emergency interconnections. No such agreement shall be amended, modified, or otherwise changed except upon the prior written approval of the Commission.

(xii) The Commission reserves the right to order all use of the Emergency Interconnection to be discontinued, and the other Contract Customer and Montgomery shall agree, in writing, to discontinue such use, at any time the terms, conditions, and limitations of this Subsection 9.N and any such additional or other terms, conditions and limitations imposed by the Commission pursuant to any policy established by the Commission with respect to emergency interconnections are not satisfied.

No emergency interconnection between the Montgomery Unit System and a water distribution system owned and operated by any other person, firm, or organization shall be constructed, operated, or maintained except upon the prior written approval of Commission.

SECTION 10. SCHEDULE FOR COMPLETION OF VARIOUS FACILITIES.

A. Plans and Specifications for Montgomery Unit System Connection Facilities. Montgomery shall prepare and submit to the Commission for its review and approval, complete detailed plans, specifications, and construction contract documents for the Montgomery Unit System Connection Facilities not later than 208 weeks after the effective date of this Contract. The Commission shall provide its comments and revisions to Montgomery within 4 weeks after receipt of such documents. Montgomery shall incorporate all required changes to such documents within 12 weeks after receipt

of the Commission's comments and revisions.

B. IEPA and Other Approvals for Montgomery Unit System Connection Facilities. Montgomery shall, within one week after receipt of the Commission's comments and revisions pursuant to Subsection 10.A above, submit such finally revised documents for approval and permitting to the Illinois Environmental Protection Agency (the "IEPA") and every other federal, state, or local governmental body having jurisdiction over any element of the Montgomery Unit System Connection Facilities, and shall diligently pursue each such approval and permit until it is secured.

C. Commencement of Construction of Montgomery Unit System Connection Facilities. Montgomery shall cause construction of the Montgomery Unit System Connection Facilities to be commenced within 244 weeks after the effective date of this Contract or 7 weeks after receipt of the last approval from any governmental body required as a condition precedent to construction of the Montgomery Unit System Connection Facilities, whichever is later. Montgomery shall cause construction to be completed within 94 weeks after commencement.

D. **Intentionally Omitted.**

E. **Intentionally Omitted.**

F. **Intentionally Omitted.**

G. Transfer of Property Rights. Montgomery shall grant to the Commission all necessary easements for the Commission metering station and other facilities to be constructed pursuant to Subsection 5.A of this Contract within 26 weeks after the effective date of this Contract. Montgomery shall, immediately upon execution of this

Contract, commence all actions necessary to acquire all property rights not already owned by it necessary to fulfill the requirements of Subsection 5.A of this Contract and this Subsection 10.G.

H. Commencement of Construction of Commission Connection Facilities.

The Commission shall cause design of the Commission Connection Facilities to be commenced within 208 weeks after receipt from Montgomery of the preliminary plans and specifications for the Montgomery Unit System Connection Facilities satisfactory to the Commission or upon acquisition of all rights of way and other property by Montgomery acquired for the installation of the Commission Connection Facilities, whichever is later. The Commission shall cause construction to be completed within 104 weeks after receipt of the last approval from any governmental body required as a condition precedent to construction of the Commission Connection Facilities or May 1, 2028, whichever is later. Montgomery acknowledges and agrees, however, that the Commission may, in the exercise of its sole and absolute discretion, accelerate commencement of the design and construction of the Commission Connection Facilities, or completion of construction thereof, without in any way affecting the obligations of Montgomery under this Contract, including without limitation Montgomery's payment obligations.

I. Delivery of Water for Start-Up Purposes. The Commission shall use its best efforts, consistent with its prior obligations and legal obligations to its customers and consistent with the fair and equitable treatment of all of its Contract Customers, to supply Montgomery with Lake Water for pressure testing, disinfecting, and flushing the Montgomery Unit System, the Montgomery Unit System Connection Facilities,

and the required water storage facilities prior to completion of construction if (i) construction of the Montgomery Unit System, the Montgomery Unit System Connection Facilities, and the required water storage facilities is proceeding in the regular course to completion; (ii) the construction of the Commission Connection Facilities has been completed, other than the SCADA System facilities, to the point where the Commission Connection facilities are capable of serving their intended function or would be capable of serving their intended function except for the fact that the Montgomery Unit System or the Montgomery Unit System Connection Facilities are not complete; (iii) such Lake Water is utilized by Montgomery solely for purposes of pressure testing, disinfecting, and flushing the Montgomery Unit System, the Montgomery Unit System Connection Facilities, or the required water storage facilities; and (iv) Montgomery pays to the Commission, at the time specified in Subsection 7.H of this Contract, an amount equal to the then current price per 1,000 gallons for Operation and Maintenance Costs times the amount of water, stated in thousands of gallons, actually received from the Commission for such purposes until such time as Montgomery first becomes obligated to make payments of Operation and Maintenance Costs pursuant to Subsections 7.A and 7.M of this Contract.

J. Illustrative Schedule of Events. An “Illustrative Schedule of Events” depicting, on the basis of assumptions concerning the length of time necessary to secure various governmental approvals, the sequence of work pursuant to this Section 10 is attached to this Contract as Exhibit F. In the event of any conflict or inconsistency between the provisions of Exhibit F and the provisions of this Section 10, the provisions of this Section 10 shall control.

SECTION 11. ASSIGNABILITY.

Montgomery shall not assign or transfer this Contract or any rights or interests herein without the advance written consent of the Commission.

The right to receive all payments that are required to be made by Montgomery to the Commission in accordance with the provisions of this Contract may be assigned by the Commission to any Trustee as provided in any Bond Ordinances/Resolutions to secure the payment of the principal of and the premium, if any, and interest on the Bonds as those amounts come due, subject to the application of those payments as may be provided in any Bond Ordinances/Resolutions. Montgomery, upon notice of assignment to any such Trustee, shall make all payments directly to such Trustee. Further, the rights of the Commission to enforce the provisions of this Contract may be assigned to any such Trustee and, in such event, such Trustee shall have the right to enforce this Contract at law or in equity with or without the further consent or participation of the Commission. The Commission also may retain the right to enforce this Contract.

SECTION 12. FORCE MAJEURE.

If, by reason of a force majeure event, either party to this Contract shall be rendered unable wholly or in part to carry out its obligation under this Contract, then if such party shall give notice and full particulars of such force majeure event in writing to the other party within seven (7) days after occurrence of the event or cause relied on, the obligation of the party giving such notice, so far as it is affected by such force majeure

event, shall be suspended during the continuance of the inability then claimed, but for no longer period, and any such party shall endeavor to remove or overcome such inability with all reasonable dispatch. The term "force majeure event" as employed herein shall mean acts of God; strikes, lockouts, or other industrial disturbances; acts of a public enemy; orders of any kind of the Government of the United States, of the State of Illinois, or of any civil or military authority; insurrections; riots; epidemics; pandemics; landslides; lightning; earthquakes; fires; hurricanes; storms; floods; washouts; droughts; arrests; restraints of government and people; civil disturbances; explosions, breakage, or accidents to machinery, pipelines, canals, or tunnels; partial or entire failure of water supply; and inability on the part of the Commission to deliver Lake Water hereunder, or of Montgomery to receive Lake Water hereunder, on account of any other causes not reasonably within the control or ability to cure of the party claiming such inability. The settlement of strikes and lockouts shall be entirely within the discretion of the party having the difficulty and the above requirement that any force majeure event shall be remedied with all reasonable dispatch shall not require the settlement of strikes and lockouts by acceding to the demands of the opposing party or parties when such settlement is unfavorable to it in the judgment of the party having the difficulty. No force majeure event which renders either of the parties unable to perform under this Contract shall relieve Montgomery of its obligation to make payments to the Commission as required under Section 7 of this Contract and such payments shall continue as if the Montgomery Unit System were receiving its Full Water Requirements from the Commission.

SECTION 13. COMMISSION DEFAULTS.

Failure by the Commission to deliver Lake Water to Montgomery as required by this Contract or failure of the Commission to perform any other obligation under this Contract, and the continuation of that failure to perform for 30 days after written notice from Montgomery to the Commission of such failure, shall be a default of the Commission under this Contract, unless any such failure is excused pursuant to Section 12 of this Contract. If the Commission defaults under this Contract, then Montgomery may bring any action against the Commission allowed by law. No Commission default shall relieve Montgomery of its obligation to make payments to the Commission as required under Section 7 of this Contract and such payments shall continue as if the Montgomery Unit System were receiving its Full Water Requirements from the Commission.

SECTION 14. MONTGOMERY OBLIGATION UNCONDITIONAL.

Montgomery shall have no right to terminate, cancel, or rescind this Contract; no right to withhold from the Commission or any Trustee who is an assignee of the Commission pursuant to Section 11 of this Contract payments due or to become due under this Contract; no right to recover from the Commission or any such Trustee amounts previously paid under this Contract unless paid in error or contrary to the provisions of this Contract or law; no right of reduction or set-off against the amounts due or to become due under this Contract to the Commission or any such Trustee; and no lien on any amounts in any fund established by the Commission or such Trustee for any reason or on account of the existence or occurrence of any event, condition, or

contingency, whether foreseen or unforeseen or foreseeable or unforeseeable by Montgomery or the Commission or any other person, including by way of illustration and not limitation by reason of the fact that the Waterworks System in whole or in part is not completed, operable, or operating; or the output of the Waterworks System in whole or in part is suspended, interrupted, interfered with, reduced, or curtailed; or any party to the Water Supply Contract does not perform in whole or in part thereunder; or the Water Allocation of any of the Commission's Contract Customers is modified or terminated or any such Contract Customer does not perform in whole or in part any agreement or instrument, it being the intent hereof that Montgomery shall be absolutely and unconditionally obligated to make all payments under this Contract. The Commission may issue Bonds in specific reliance on the limitations set forth in this Section 14 with respect to the rights of Montgomery.

SECTION 15. COOPERATION IN CONSTRUCTION; EASEMENTS.

Montgomery shall cooperate with the Commission in the construction and acquisition of the Waterworks System. Montgomery is responsible for acquiring all necessary real property and easements within the Village to build the Connection Facilities and shall transfer that insured real property and insured easements to the Commission upon acquisition. Additionally, Montgomery, within 30 days after Commission's request therefor, shall grant without charge to the Commission all required construction easements and all insured easements necessary for portions of the Waterworks System to be located on Montgomery's property, free and clear of all liens, claims, encumbrances, and restrictions unless otherwise approved by the Commission in

writing, provided the Commission agrees to restore the easement property in a reasonable manner after construction. Montgomery shall grant the Commission all access to its property necessary to construct and install the Commission Connection Facilities and all other equipment and appurtenant devices to the Point of Delivery.

SECTION 16. COOPERATION IN ISSUANCE OF BONDS.

Montgomery shall cooperate with the Commission in the issuance of Bonds. In connection therewith, Montgomery shall comply with all reasonable requests of the Commission and shall upon request do as follows:

- A. Make available general and financial information about itself in accordance with GAAP; and
- B. Consent to publication and distribution of its financial information; and
- C. Certify that general and financial information about it is accurate, does not contain an untrue statement of a material fact, and does not omit to state a material fact necessary in order to make the statements in that information, in light of the circumstances under which they were made, not misleading; and
- D. Make available certified copies of official proceedings; and
- E. Provide reasonable certifications to be used in a transcript of closing documents; and
- F. Provide and pay for reasonably requested opinions of counsel of its choice as to the validity of its actions taken with respect to, and the binding effect of, this Contract, title to the Montgomery Unit System, pending or threatened litigation which could materially affect its performance hereunder, and other reasonably related opinions.

SECTION 17. REGULATORY BODIES.

The Commission and Montgomery through this Contract seeks to exercise and maintain all sovereign rights granted to it under and through the Constitution and laws

of the State of Illinois. This Contract shall be subject to all valid rules, regulations, and laws applicable hereto passed or promulgated by the United States of America, the State of Illinois, any governmental body or agency having lawful jurisdiction, and any authorized representative or agent of any of them; provided, however, that this clause shall not be construed as waiving the right of either party to challenge the validity of such rule, regulation, or law on any basis, including the impairment of this Contract.

SECTION 18. OTHER WATER SUPPLIERS.

Notwithstanding any of the provisions of this Contract, the Commission is not prohibited by this Contract from entering into cooperative arrangements with other suppliers or users of Lake Water to provide Lake Water to each other to meet each other's water needs, provided that these arrangements do not interfere, except in emergencies, with the delivery of Lake Water to the Montgomery Unit System.

SECTION 19. NOTICES; EVIDENCE OF ACTIONS; WAIVER.

A. Notices. All notices or communications provided for herein shall be in writing and shall be delivered either in person or by United States mail, by certified mail with return receipt requested, postage prepaid, and addressed as follows:

To the Commission:

DuPage Water Commission
600 East Butterfield Road
Elmhurst, IL 60126
Attention: General Manager

To Montgomery:
Village of Montgomery
200 N. River Street
Montgomery IL 60538
Attention: Village Administrator

Copy to:
Laura M. Julien
Village Attorney
Mickey, Wilson, Weiler, Renzi, Lenert & Julien PC
140 Municipal Drive
Sugar Grove, IL 60554

until and unless other addresses or addressees are specified by notice given in accordance herewith.

B. Evidence of Actions. Any action hereunder to be taken by the Commission or Montgomery may be evidenced by copy of official proceedings (including pertinent minutes, motions, resolutions, or ordinances, as applicable) duly certified by the Clerk of the Commission or the Village Clerk of Montgomery.

All notices, demands, requests, consents, approvals, and other instruments required or permitted to be made or given by Montgomery pursuant to this Contract shall be in writing, signed by a duly authorized officer, agent, or attorney of Montgomery.

C. Waiver. No course of dealing or failure of the Commission or Montgomery to enforce strictly any term, right, or condition of this Contract shall be construed as a waiver of such term, right, or condition. No express waiver of any term, right, or condition of this Contract shall operate as a waiver of any other term, right, or condition.

D. Partial Invalidity. If a term or provision of this Contract or the application thereof to any person or circumstances shall, to any extent, be invalid or unenforceable,

the remainder of this Contract, or the application of such term or provision to persons or circumstances other than those as to which it is held invalid or unenforceable, shall not be affected thereby, and each such term and provision of this Contract shall be valid and be enforced to the fullest extent permitted by law.

SECTION 20. EFFECTIVE DATE; TERMINATION; PAYMENT OF INTERIM COSTS; TERM.

A. Effective Date. Except for the provisions of Section 10 of this Contract relating to the commencement of certain work following execution of this Contract and except for the provisions of Section 20.C of this Contract relating to the payment of certain costs, as to which provisions this Contract shall be effective immediately after authorization and execution by both parties hereto, this Contract shall be effective upon authorization and execution by both parties hereto and issuance by the State of Illinois Department of Natural Resources, Office of Water Resources, of a Water Allocation permit to Montgomery for each discrete and non-contiguous service area served by the Montgomery Unit System.

B. Commission Right to Terminate. If the Montgomery Unit System has not been constructed, installed, and completed to a point where it is capable of serving its intended function at the time Montgomery first becomes obligated to make payments of Operation and Maintenance Costs pursuant to Subsection 7.M of this Contract, the Commission may, in its sole and absolute discretion, terminate this Contract, in which event the Commission shall give notice to Montgomery not less than 20 days in advance of its intention to terminate this Contract and shall provide Montgomery an opportunity for a hearing before the Commission prior to the effective date of such

termination and, upon the concurrence of a majority of the Commissioners of the Commission following the conclusion of such hearing, this Contract shall be of no further force or effect except for the provisions of Subsection 20.D below, as to which provisions this Contract shall remain in full force and effect.

C. Payment of Interim Costs. Whether or not the Montgomery Unit System is ever completed, operable, or operating, Montgomery shall pay to the Commission all attorneys', engineering, and administrative fees, costs, and expenses incurred by the Commission for any work related to, or participation in, any regulatory proceeding which shall be required or requested of the Commission by the Illinois Department of Natural Resources, Office of Water Resources, or by Montgomery as a result of, or occasioned by, this Contract and, further, shall pay to the Commission all attorneys', engineering, and administrative fees, costs, and expenses incurred by the Commission in connection with the negotiation, preparation, consideration, and review of this Contract and in implementing the terms of this Contract, including without limitation the costs of the design and construction of the Commission Connection Facilities. If the Montgomery Unit System has not been completed as and when required by Subsection 20.B above and the Commission elects, in its sole and absolute discretion, to terminate this Contract pursuant to Subsection 20.B above, then Montgomery's payment hereunder shall be due and payable immediately after receipt by it of an invoice from the Commission detailing such costs, after deducting therefrom the amount or amounts of any prepayments made pursuant to Subsection 7.K of this Contract. If the amount or amounts of any such prepayments exceed Montgomery's

payment obligation hereunder, the Commission shall refund the difference to Montgomery. If either (i) the Montgomery Unit System is completed as and when required by Subsection 20.B above or (ii) if not completed, the Commission does not elect to terminate this Contract, then such costs shall be treated as part of the Connection Facilities Cost provided in Subsection 7.C of this Contract.

D. Term. Unless this Contract is sooner terminated by the Commission pursuant to Subsection 20.B above, this Contract shall continue in force and effect until February 24, 2064.

SECTION 21. GOVERNING LAW AND VENUE.

This Contract shall be construed exclusively under the applicable laws, but not the conflicts of laws rules, of the State of Illinois. The parties agree that venue for any litigation arising out of this Contract shall only be proper in the Eighteenth Judicial Circuit Court, DuPage County, Illinois and waive any right, whether statutory or otherwise, to venue in any other jurisdiction.

SECTION 22. MUNICIPAL BOUNDARIES.

Not later than 365 days after the execution of this Contract, Montgomery shall provide the Commission with: (i) a current list of all parcels within Montgomery's corporate limits, identified by Property Index Number and common address, (ii) a correct, complete legal description of the entire boundary of the municipality, and (iii) an aerial photograph depicting the entire boundary of the Montgomery municipal limits. Montgomery shall update the information in this Section 22 within 60 days of any changes in its municipal boundaries.

SECTION 23. MODIFICATIONS OR AMENDMENTS.

This Contract shall not be modified or amended in any way except in writing approved by both parties hereto. No such modification or amendment shall materially impair or adversely affect the ability or obligation of Montgomery to make payments to the Commission to meet the Commission's obligations under the Water Supply Contract, the Contract Customer Contract, and the Bond Ordinances/Resolutions.

SECTION 24. EXHIBITS INCORPORATED.

Exhibits A, B-1, B-2, C, D, E, F and G to this Contract are hereby fully incorporated into this Contract as substantive provisions of this Contract.

SECTION 25. EXECUTION IN COUNTERPARTS.

This Contract shall be executed in two counterparts, each of which shall be deemed to be an original, and each of which shall constitute but one and the same instrument.

[SIGNATURE PAGE FOLLOWS]

IN WITNESS WHEREOF, the parties hereto have caused their respective corporate names to be subscribed hereto and their respective corporate seals to be affixed hereto and attested by their duly authorized officers, all on the date set opposite their respective corporate names.

Date: _____

VILLAGE OF MONTGOMERY

By: _____
Matt Brolley – Village President

ATTEST:

Debbie Buchanan – Village Clerk

Date: _____

DUPAGE WATER COMMISSION

By: _____
James F. Zay – Chairman

ATTEST:

Danna M. Mundall – Clerk

EXHIBIT A
MONTGOMERY UNIT SYSTEM

Village of Montgomery
Water Purchase and Sale Contract

EXHIBIT A MONTGOMERY UNIT SYSTEM

VOM Water System

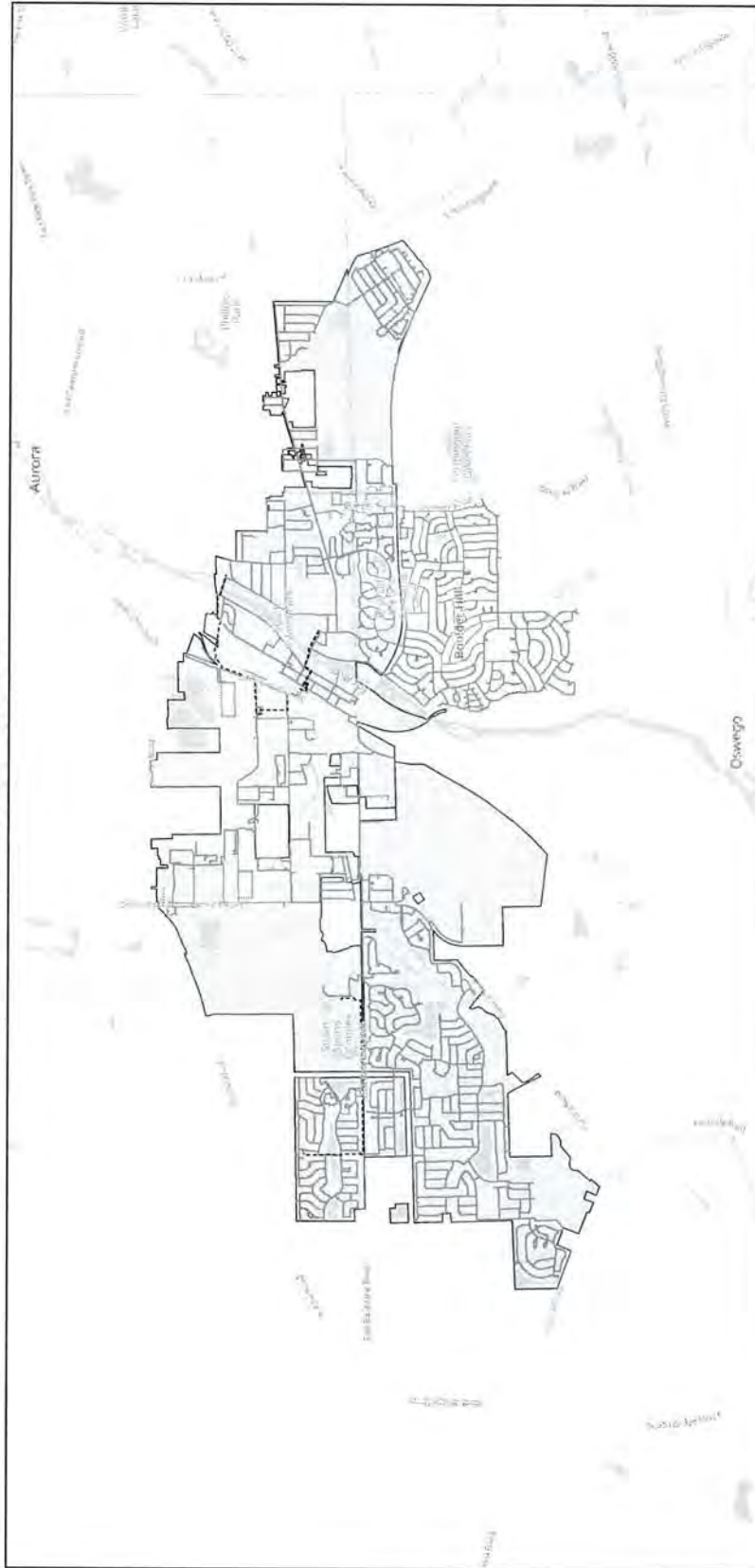

9/12/2024

----- Raw WM

— Private Water Main

— Montgomery Water Main

— Boulder Hill Water Main

□ VOM Limits Boundary Final

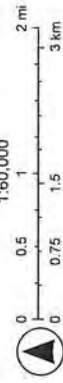

Map data © OpenStreetMap contributors, Microsoft, Facebook, Inc and its affiliates, Esri Community Maps contributors, Map layer by Esri

EXHIBIT B-1
MONTGOMERY UNIT SYSTEM CONNECTION FACILITIES

Village of Montgomery
Water Purchase and Sale Contract

EXHIBIT B-1 MONTGOMERY UNIT SYSTEM CONNECTION FACILITIES MS31A SITE

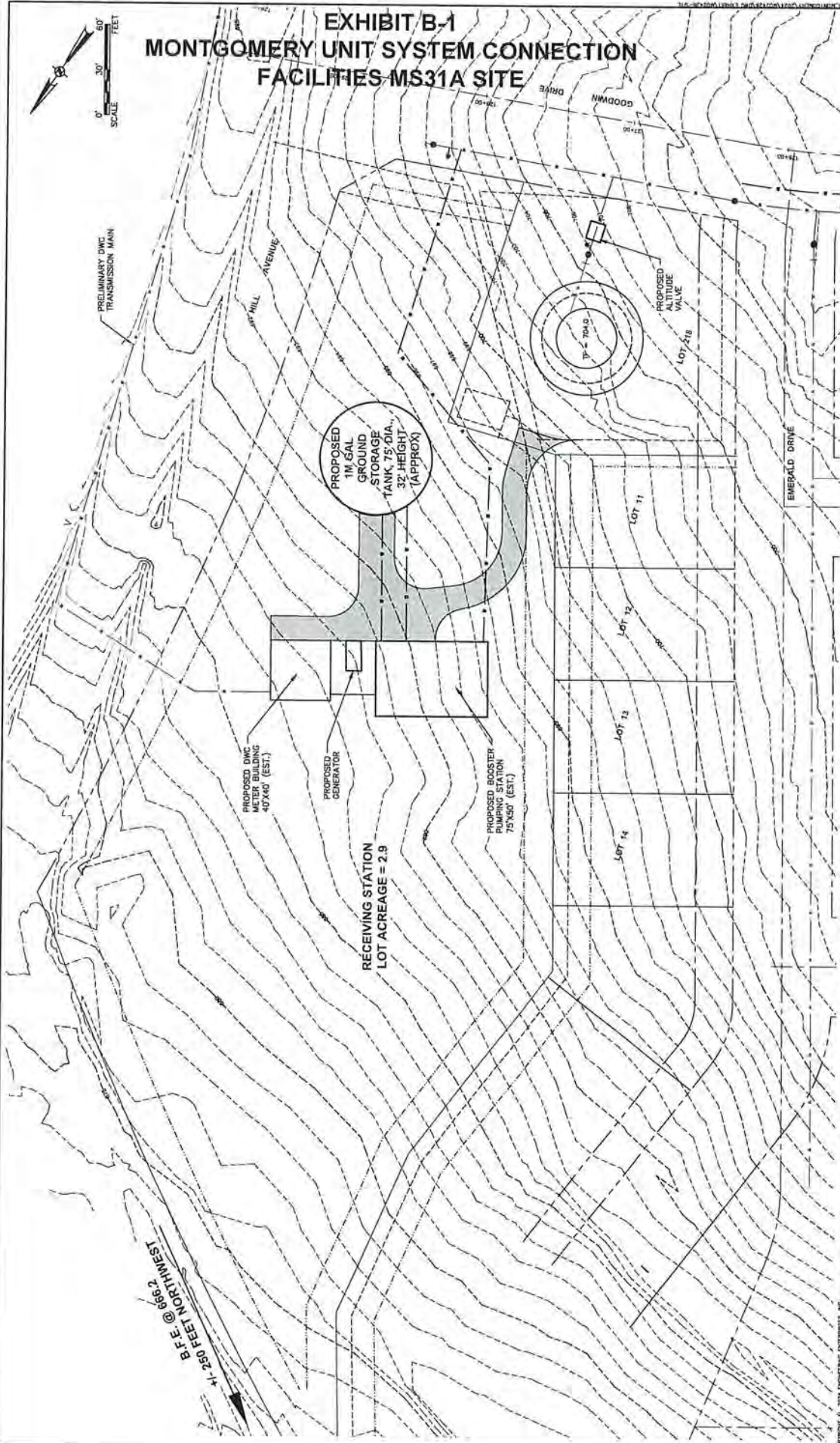

DATE: OCTOBER 2024
PROJECT NO: M02428
FILE: M02428-SITE
SHEET 1 OF 1

PROPOSED EAST RECEIVING STATION
SITE PLAN
(PRELIMINARY)

LAKE MICHIGAN CONNECTION
PRELIMINARY ENGINEERING
LAKE MICHIGAN WATER

NO.	DATE	REVISIONS

1" = 100'
VERTICAL SCALE
AS SHOWN
UNLESS NOTED OTHERWISE

VILLAGE OF MONTGOMERY
KANE & KENDALL, COUNTIES, IL

Engineering Enterprises, Inc.
CONSULTING ENGINEERS
22 Wheeler Road, #6054
Evanston, IL 60201
630.466.2700 / www.eent.com



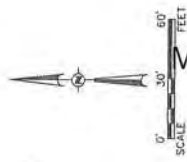
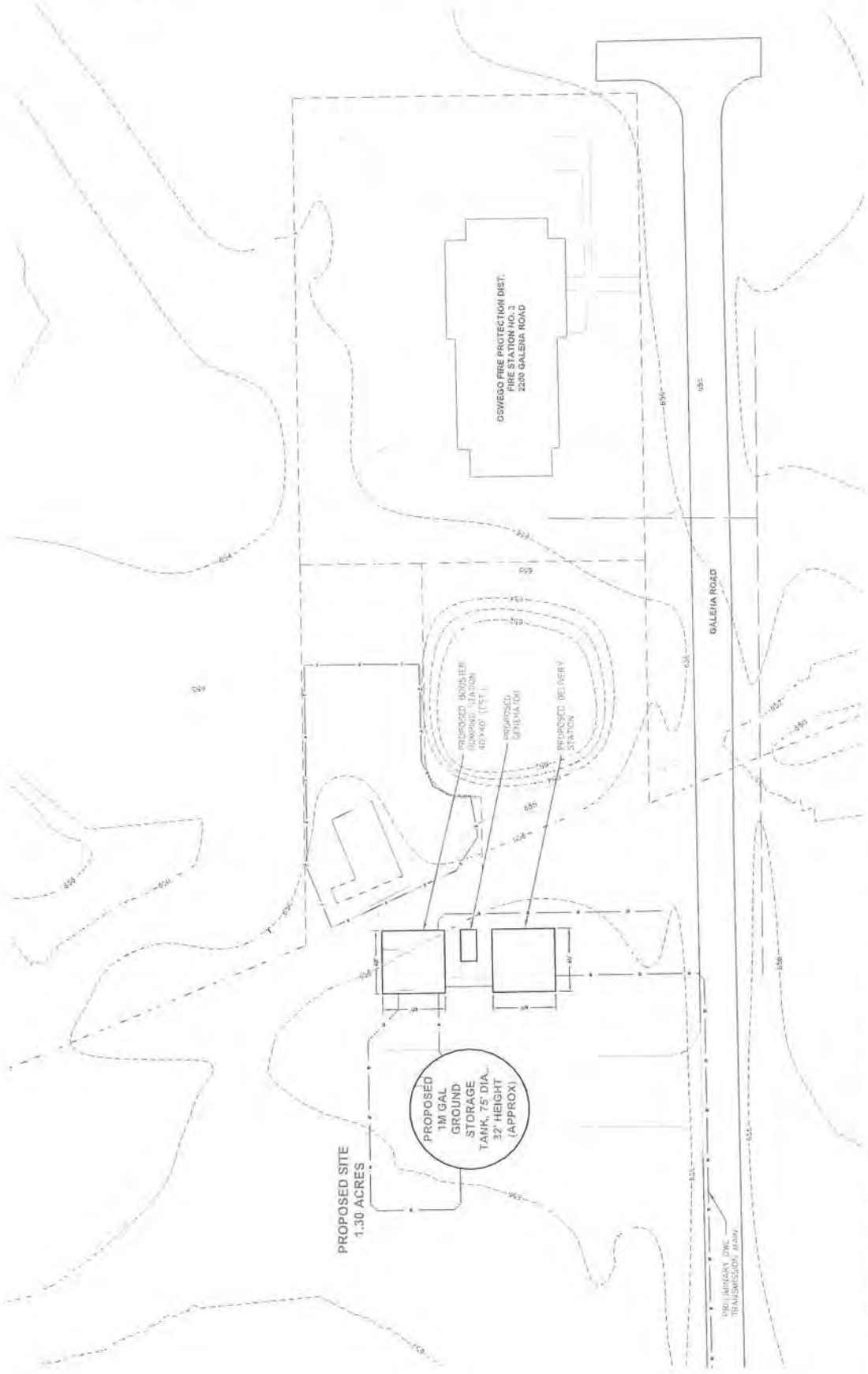

EXHIBIT B-1 MONTGOMERY UNIT SYSTEM CONNECTION FACILITIES MS 31B SITE



DATE: AUGUST 2022
PROJECT NO. M0224
FILE:
SHEET 1 OF 1

PROPOSED WEST RECEIVING STATION
SITE PLAN
(PRELIMINARY)

NO.	DATE	REVISIONS

VILLAGE OF MONTGOMERY
KANE COUNTY, ILLINOIS

Engineering Enterprises, Inc.
CONSULTING ENGINEERS
28 Alton Road
Burlington, IL 60108
630-468-6300 / www.eent.com



EXHIBIT B-1

WATER DELIVERY DATA

DU PAGE WATER COMMISSION

Date: July 31, 2023

CUSTOMER NAME Village of Montgomery (data supplied by Customer's consultant)

DELIVERY POINT (DWC NODE No.) MS 31A

TYPE OF CUSTOMER PAS FACILITY REQUIRED Pressure Reducing Type B

LOCATION AT Ogden Hill EWST, 1070 Emerald Dr. Montgomery, IL

DWC DESIGN MINIMUM HYDRAULIC GRADE* (USGS DATUM) 841

CUSTOMER'S SYSTEM OVERFLOW ELEV. AND/OR REQUIRED HEAD** 844

CUSTOMER'S STORAGE FACILITY 1.0 MG Elevated Storage (additional storage planned)

HYDRAULIC DATA

	Flow Rate @ Customer's Facility MGD	DWC Hydraulic Grade 10 ft. Downstream of DWC Meter Station USGS Datum
<u>2032</u> Avg. Day	<u>0.85</u>	<u>879</u>
<u>2032</u> Max. Day	<u>2.12</u>	<u>898</u>
<u>2050</u> Avg. Day	<u>1.04</u>	<u>841</u>
<u>2050</u> Max. Day	<u>2.60</u>	<u>885</u>
<u>2050</u> Peak***	<u>3.12</u>	

* DWC design minimum hydraulic grade will fluctuate approx. \pm 10 feet depending upon Commission's elevated storage water elevation.

** It is customer's responsibility to verify the system overflow elevation or required head.

*** 3 x 2050 average day flow or 1500 GPM minimum.

EXHIBIT B-1

WATER DELIVERY DATA

DU PAGE WATER COMMISSION

Date: July 31, 2023

CUSTOMER NAME Village of Montgomery (data supplied by Customer's consultant)

DELIVERY POINT (DWC NODE No.) MS 31B

TYPE OF CUSTOMER PAS FACILITY REQUIRED Pressure Reducing Type A

LOCATION AT West Connection Point, Galena Rd. east of Orchard Rd., adjacent to (west of) Oswego Fire Protection District Station 3, Montgomery, IL

DWC DESIGN MINIMUM HYDRAULIC GRADE* (USGS DATUM) 841

CUSTOMER'S SYSTEM OVERFLOW ELEV. AND/OR REQUIRED HEAD** 832

CUSTOMER'S STORAGE FACILITY 1.0 MG Ground Storage (planned storage)

HYDRAULIC DATA

	Flow Rate @ Customer's Facility MGD	DWC Hydraulic Grade 10 ft. Downstream of DWC Meter Station USGS Datum
<u>2032</u> Avg. Day	<u>1.27</u>	<u>879</u>
<u>2032</u> Max. Day	<u>2.13</u>	<u>898</u>
<u>2050</u> Avg. Day	<u>1.56</u>	<u>839</u>
<u>2050</u> Max. Day	<u>2.63</u>	<u>883</u>
<u>2050</u> Peak***	<u>4.68</u>	

* DWC design minimum hydraulic grade will fluctuate approx. \pm 10 feet depending upon Commission's elevated storage water elevation.

** It is customer's responsibility to verify the system overflow elevation or required head.

*** 3 x 2050 average day flow or 1500 GPM minimum.

EXHIBIT B-1

PRELIMINARY PLANS FOR THE MONTGOMERY
UNIT SYSTEM CONNECTION FACILITIES

MINIMUM REQUIREMENTS FOR PRESSURE ADJUSTING (PA) STATIONS
AND SCHEMATICS

1. Rate Controllers shall be adjusted and the water distribution shall otherwise be operated to take a normally uniform flow rate from the DWC system. The maximum hourly rate should in no case be greater than 1.7 times the average annual hourly rate based on the current Lake Michigan water allocation for the PA station. The adequacy of customer system storage and proper operation of storage facilities to assure uniform take-off is the customer's responsibility.
2. Designs shall provide for the appropriate fluctuation of customer storage facility levels to assure uniform take-off. Elevated storage tanks shall be fluctuated appropriately during sub freezing conditions.
3. Emergency bypass lines, flow rate controllers and system isolation check valves shall be required in all designs.
4. Altitude valves or other appropriate means for preventing elevated and ground storage tank overflows are recommended if such provisions do not already exist in the customer's system.
5. Surge relief facilities for protection of both the customer and DWC facilities shall be required.
6. the type and design of the PA station will be dependent upon:
 - a. The difference between, (i) the minimum DWC system pressure (hydraulic grade) 10 feet downstream of the DWC Metering Station (MS) and, (ii) the customer's elevated tank overflow or system pressure.
 - b. Whether ground storage will be used to receive water at the PA station.

In general, the recommended design types for the various receiving facility designs and the differential between the minimum DWC system grade (at the point of delivery) and the customer system elevated tank overflows or system pressure are as follows:

<u>Design Type</u>	<u>Head (DWC – Customer)</u>
Pressure Reducing (Type A & B)	> / = 28 feet
Rate Control (Type C)	< 28 feet & >/= 0 feet
Pressure Increasing (Type D)	< 0 feet

EXHIBIT B-1

PRELIMINARY PLANS FOR THE MONTGOMERY UNIT SYSTEM CONNECTION FACILITIES

7. Where pumping stations are required (Type D), each station shall be equipped with three (3) pumping units of equal size. Each unit shall have rated capacity of approximately equal to the average day, year 2020 flow, at the station. Two (2) pumping units shall have a combined capacity to provide maximum day, year 2020 flow (1.7 times average day year 2020 flow). The third unit is for standby. A fourth space is shown on the pumping station (Type D) schematic for an additional pumping unit at the customer's option.
8. The facility requirements indicated are for illustrative purposes showing general guidelines and various design functions to be provided. Each station shall be designed and proper equipment shall be selected to meet local and specific conditions.
9. Emergency conditions may permit three (3) times average day flow at the PA based on the year 2020 Lake Michigan Water Allocation or 1500 GPM, whichever is greater.
10. The Commission will only provide a chlorine residual meeting State and Federal Standards at the point of delivery. Additional chlorination facilities, if required, shall be provided by the customer at the customer's expense.

EXHIBIT B-1 MONTGOMERY UNIT SYSTEM CONNECTION FACILITIES

PRESSURE REDUCING STATION - TYPE A

- 1) HOURLY FLOWS SHALL BE UNIFORM THROUGHOUT EACH DAY* AND RATE NOT EXCEED 1.7 X AVERAGE DAY FLOW AT THE STATION BASED ON CURRENT YEAR LAKE MICHIGAN WATER ALLOCATION.
- 2) PRESSURE REDUCING STATION IS REQUIRED IF THE COMMISSION'S SYSTEM DESIGN PRESSURE** EXCEEDS THE DESIRED CUSTOMER'S SYSTEM PRESSURE BY TWELVE (12) P.S.I. (28 FT.) OR MORE.
- 3) PRESSURE REDUCING STATION TYPE A - CONNECTIONS TO GROUND RESERVOIR AND SYSTEM.
 - A. PRESSURE REDUCING AND CHECK VALVE, AND RATE CONTROLLER (MAXIMUM FLOW LIMIT CONTROL) ARE REQUIRED.
 - B. PRESSURE RELIEF FOR BOTH DWC AND CUSTOMER'S SYSTEM IS REQUIRED.
 - C. EMERGENCY BYPASS IS REQUIRED.
 - D. ALTITUDE VALVE WITH PRESSURE SUSTAINING FUNCTION AND BYPASS (CUSTOMER'S RESPONSIBILITY) ARE RECOMMENDED FOR GROUND RESERVOIR CONNECTION. PROPER DAILY USE OF THE RESERVOIR IS REQUIRED.
 - E. CHLORINATION SYSTEM IS OPTIONAL (CUSTOMER'S RESPONSIBILITY).
- 4) EMERGENCY CONDITIONS MAY PERMIT 3X AVERAGE DAY FLOW AT THE STATION BASED ON 2020 LAKE MICHIGAN WATER ALLOCATION OR 1500 GPM WHICHEVER IS LARGER.
- 5) STANDBY PRESSURE REDUCING AND CHECK VALVE ARE REQUIRED.
- 6) THE FACILITY REQUIREMENTS INDICATED ARE FOR ILLUSTRATIVE PURPOSE SHOWING GENERAL GUIDELINES AND VARIOUS DESIGN FUNCTIONS TO BE PROVIDED. EACH STATION SHALL BE DESIGNED, AND PROPER EQUIPMENT SHALL BE SELECTED TO MEET LOCAL CONDITIONS AND SITE SPECIFICS.

*ACCOMPLISHED BY SETTING RATE CONTROLLER IN ACCORDANCE WITH THE CUSTOMER DEMAND.

**DESIGN PRESSURE WILL FLUCTUATE APPROXIMATELY + 10 FEET DEPENDING UPON COMMISSION'S ELEVATED STORAGE WATER ELEVATION.

SCHEMATIC OF PRESSURE REDUCING STATION TYPE A

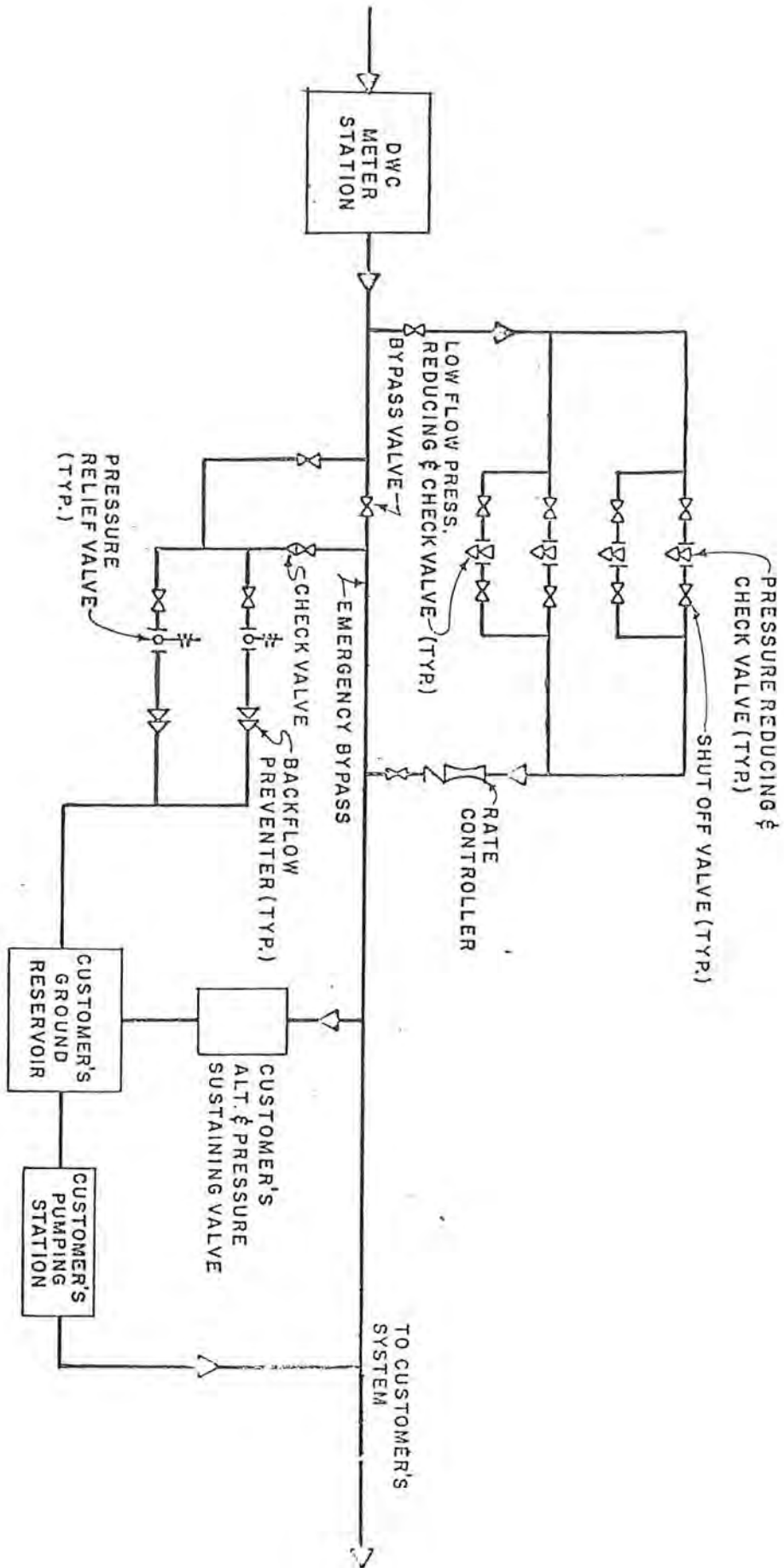

DUPAGE WATER COMMISSION
DATE:

ALVORD, BURDICK & HOWSON
ENGINEERS CHICAGO

EXHIBIT B-1 MONTGOMERY UNIT SYSTEM CONNECTION FACILITIES

PRESSURE REDUCING STATION - TYPE B

- 1) HOURLY FLOWS SHALL BE UNIFORM THROUGHOUT EACH DAY* AND RATE NOT EXCEED 1.7 X AVERAGE DAY FLOW AT THE STATION BASED ON CURRENT YEAR LAKE MICHIGAN WATER ALLOCATION.
- 2) PRESSURE REDUCING STATION IS REQUIRED IF THE COMMISSION'S SYSTEM DESIGN PRESSURE** EXCEEDS THE DESIRED CUSTOMER'S SYSTEM PRESSURE BY TWELVE (12) P.S.I. (28 FT.) OR MORE.
- 3) PRESSURE REDUCING STATION TYPE B - CONNECTIONS TO ELEVATED TANK AND SYSTEM.
 - A. PRESSURE REDUCING AND CHECK VALVE, AND RATE CONTROLLER (MAXIMUM FLOW LIMIT CONTROL) ARE REQUIRED.
 - B. PRESSURE RELIEF FOR BOTH DWC AND CUSTOMER'S SYSTEM IS REQUIRED.
 - C. EMERGENCY BYPASS IS REQUIRED.
 - D. ALTITUDE VALVE WITH BYPASS (CUSTOMER'S RESPONSIBILITY) IS RECOMMENDED FOR ELEVATED TANK CONNECTION. PROPER DAILY USE OF THE TANK IS REQUIRED.
 - E. CHLORINATION SYSTEM IS OPTIONAL (CUSTOMER'S RESPONSIBILITY).
- 4) EMERGENCY CONDITIONS MAY PERMIT 3X AVERAGE DAY FLOW AT THE STATION BASED ON 2020 LAKE MICHIGAN WATER ALLOCATION OR 1500 GPM WHICHEVER IS LARGER.
- 5) STANDBY PRESSURE REDUCING AND CHECK VALVE ARE REQUIRED.
- 6) THE FACILITY REQUIREMENTS INDICATED ARE FOR ILLUSTRATIVE PURPOSE SHOWING GENERAL GUIDELINES AND VARIOUS DESIGN FUNCTIONS TO BE PROVIDED. EACH STATION SHALL BE DESIGNED, AND PROPER EQUIPMENT SHALL BE SELECTED TO MEET LOCAL CONDITIONS AND SITE SPECIFICS.

*ACCOMPLISHED BY SETTING RATE CONTROLLER IN ACCORDANCE WITH THE CUSTOMER DEMAND.

**DESIGN PRESSURE WILL FLUCTUATE APPROXIMATELY + 10 FEET DEPENDING UPON COMMISSION'S ELEVATED STORAGE WATER ELEVATION.

SCHEMATIC OF PRESSURE REDUCING STATION TYPE B

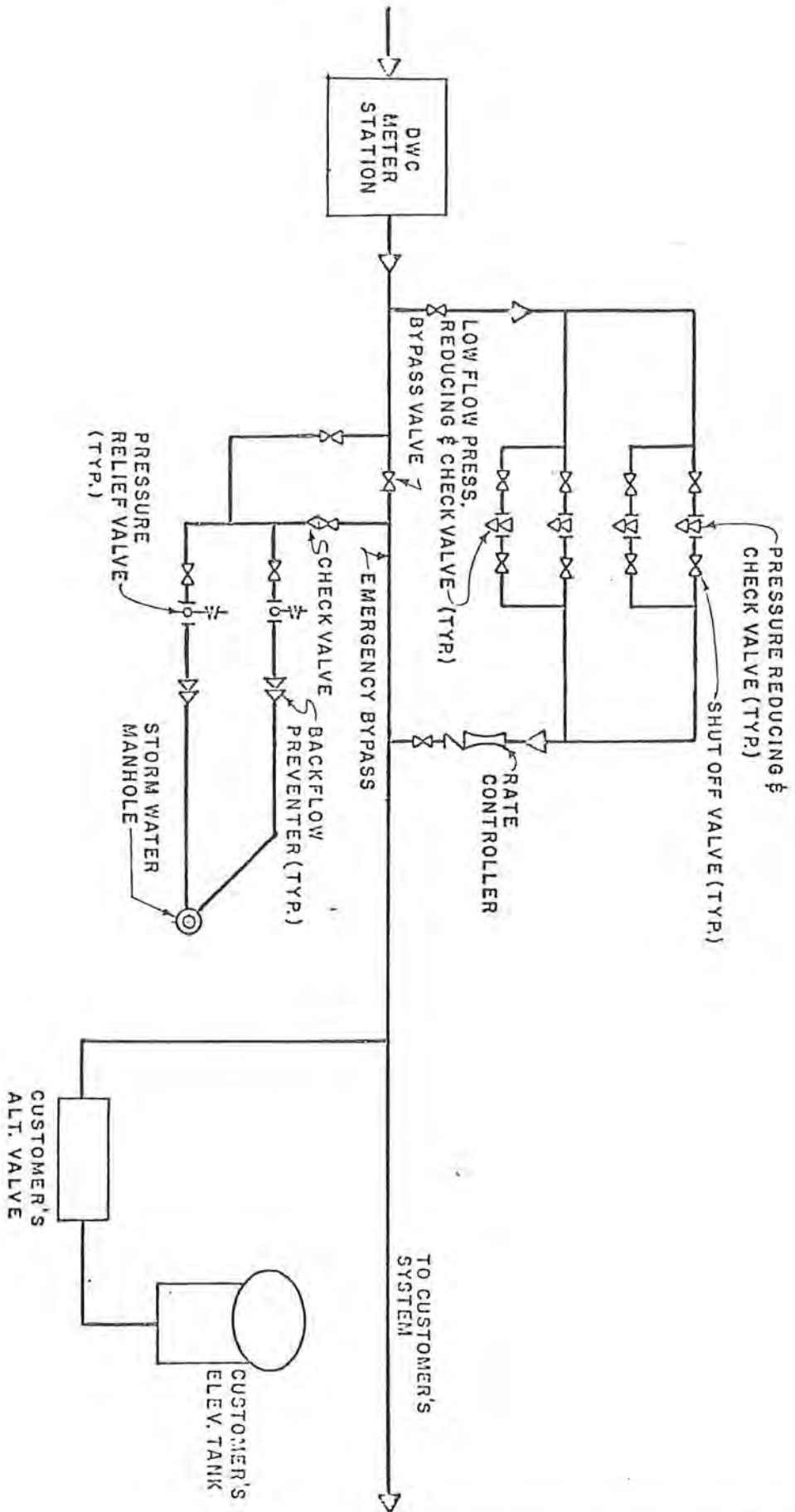

DUPAGE WATER COMMISSION
DATE:

ALVORD, BURDICK & HOWSON
ENGINEERS CHICAGO

EXHIBIT B-1 MONTGOMERY UNIT SYSTEM CONNECTION FACILITIES

PRESSURE REDUCING STATION - TYPE C

- 1) HOURLY FLOWS SHALL BE UNIFORM THROUGHOUT EACH DAY* AND RATE NOT EXCEED 1.7 X AVERAGE DAY FLOW AT THE STATION BASED ON CURRENT YEAR LAKE MICHIGAN WATER ALLOCATION.
- 2) PRESSURE REDUCING STATION IS REQUIRED IF THE COMMISSION'S SYSTEM DESIGN PRESSURE** EXCEEDS THE DESIRED CUSTOMER'S SYSTEM PRESSURE BY TWELVE (12) P.S.I. (28 FT.) OR MORE.
- 3) PRESSURE REDUCING STATION TYPE C - DIRECT CONNECTIONS TO DISTRIBUTION SYSTEM.
 - A. ALL DIRECT CONNECTIONS FROM DUPAGE WATER COMMISSION FEEDER MAIN TO DISTRIBUTION SYSTEM SHALL REQUIRED DWC APPROVAL.
 - B. MAXIMUM HOUR TAKE-OFF RATE SHALL BE REGULATED TO COMPLY WITH ITEM 1) REQUIREMENTS. ADEQUACY OF STORAGE CAPACITY IS CUSTOMER'S RESPONSIBILITY.
 - C. PRESSURE REDUCING AND CHECK VALVE, AND RATE CONTROLLER (MAXIMUM FLOW LIMIT CONTROL) ARE REQUIRED.
 - D. PRESSURE RELIEF FOR BOTH DWC AND CUSTOMER'S SYSTEM IS REQUIRED.
 - E. EMERGENCY BYPASS IS REQUIRED.
 - F. ALTITUDE VALVE WITH BYPASS (AND PRESSURE SUSTAINING FUNCTION FOR GROUND STORAGE) IS RECOMMENDED FOR STORAGE CONNECTION (CUSTOMER'S RESPONSIBILITY). PROPER DAILY USE OF THE STORAGE IS REQUIRED.
 - G. CHLORINATION SYSTEM IS OPTIONAL (CUSTOMER'S RESPONSIBILITY).
- 4) EMERGENCY CONDITIONS MAY PERMIT 3X AVERAGE DAY FLOW AT THE STATION BASED ON 2020 LAKE MICHIGAN WATER ALLOCATION OR 1500 GPM WHICHEVER IS LARGER.
- 5) STANDBY PRESSURE REDUCING AND CHECK VALVE ARE REQUIRED.
- 6) THE FACILITY REQUIREMENTS INDICATED ARE FOR ILLUSTRATIVE PURPOSE SHOWING GENERAL GUIDELINES AND VARIOUS DESIGN FUNCTIONS TO BE PROVIDED. EACH STATION SHALL BE DESIGNED, AND PROPER EQUIPMENT SHALL BE SELECTED TO MEET LOCAL CONDITIONS AND SITE SPECIFICS.

*ACCOMPLISHED BY SETTING RATE CONTROLLER IN ACCORDANCE WITH THE CUSTOMER DEMAND.

**DESIGN PRESSURE WILL FLUCTUATE APPROXIMATELY + 10 FEET DEPENDING UPON COMMISSION'S ELEVATED STORAGE WATER ELEVATION.

SCHEMATIC OF PRESSURE REDUCING STATION TYPE C

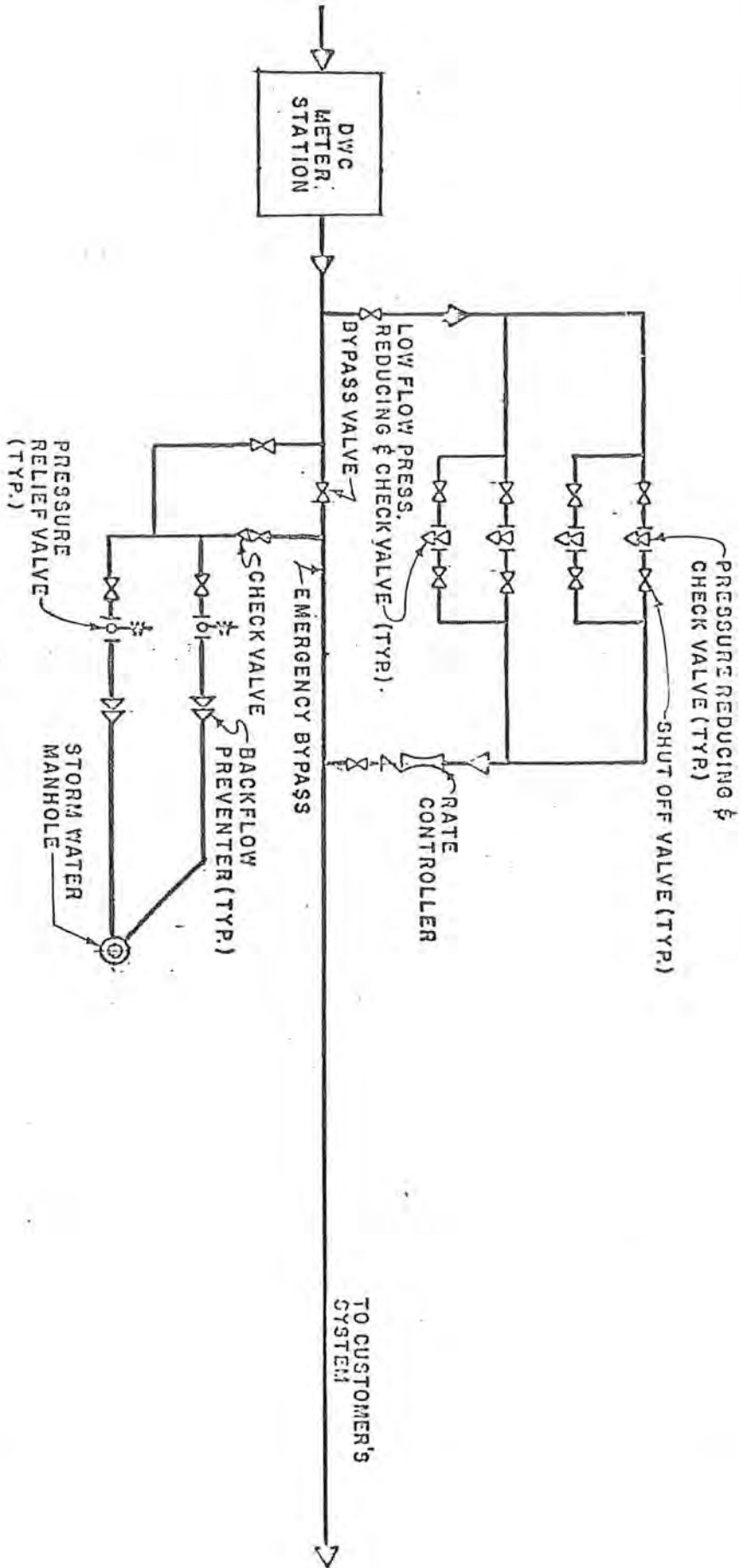

DU PAGE WATER COMMISSION
DATE:

ALVORD, BURDICK & HOWSON
ENGINEERS CHICAGO

EXHIBIT B-1 MONTGOMERY UNIT SYSTEM CONNECTION FACILITIES

RATE CONTROL STATION - TYPE D

- 1) HOURLY FLOWS SHALL BE UNIFORM THROUGHOUT EACH DAY* AND RATE NOT EXCEED 1.7 X AVERAGE DAY FLOW AT THE STATION BASED ON CURRENT YEAR LAKE MICHIGAN WATER ALLOCATION.
- 2) RATE CONTROL STATION IS REQUIRED IF THE DIFFERENCE BETWEEN THE COMMISSION'S MINIMUM DESIGN PRESSURE** AND THE CUSTOMER'S DESIRED SYSTEM PRESSURE IS NOT MORE THAN TWELVE (12) P.S.I. (28 FT.).
- 3) RATE CONTROL STATION TYPE D - CONNECTIONS TO ELEVATED TANK AND SYSTEM.
 - A. PRESSURE SUSTAINING AND CHECK VALVE, AND RATE CONTROLLER (MAXIMUM FLOW LIMIT CONTROL) ARE REQUIRED.
 - B. PRESSURE RELIEF FOR BOTH DWC AND CUSTOMER'S SYSTEM IS REQUIRED.
 - C. EMERGENCY BYPASS IS REQUIRED.
 - D. ALTITUDE VALVE WITH BYPASS (CUSTOMER'S RESPONSIBILITY) IS RECOMMENDED FOR ELEVATED TANK CONNECTION. PROPER DAILY USE OF THE TANK IS REQUIRED.
 - E. CHLORINATION SYSTEM IS OPTIONAL (CUSTOMER'S RESPONSIBILITY).
- 4) EMERGENCY CONDITIONS MAY PERMIT 3X AVERAGE DAY FLOW AT THE STATION BASED ON 2020 LAKE MICHIGAN WATER ALLOCATION OR 1500 GPM WHICHEVER IS LARGER.
- 5) STANDBY PRESSURE SUSTAINING AND CHECK VALVE ARE REQUIRED.
- 6) THE FACILITY REQUIREMENTS INDICATED ARE FOR ILLUSTRATIVE PURPOSE SHOWING GENERAL GUIDELINES AND VARIOUS DESIGN FUNCTIONS TO BE PROVIDED. EACH STATION SHALL BE DESIGNED, AND PROPER EQUIPMENT SHALL BE SELECTED TO MEET LOCAL CONDITIONS AND SITE SPECIFICS.

*ACCOMPLISHED BY SETTING RATE CONTROLLER IN ACCORDANCE WITH THE CUSTOMER DEMAND.

**DESIGN PRESSURE WILL FLUCTUATE APPROXIMATELY + 10 FEET DEPENDING UPON COMMISSION'S ELEVATED STORAGE WATER ELEVATION.

SCHEMATIC OF PRESSURE INCREASING STATION TYPE D

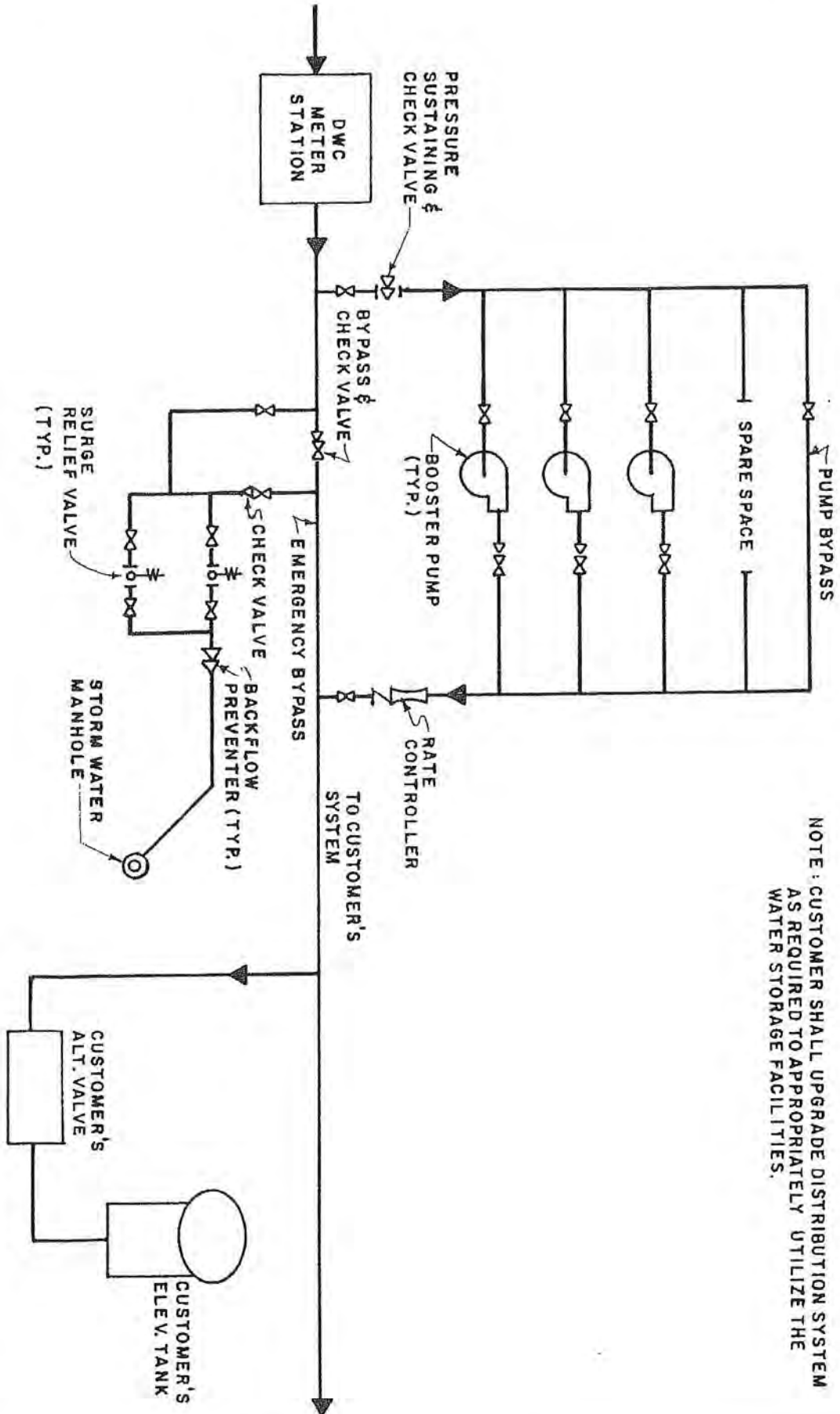

NOTE: CUSTOMER SHALL UPGRADE DISTRIBUTION SYSTEM AS REQUIRED TO APPROPRIATELY UTILIZE THE WATER STORAGE FACILITIES.

DU PAGE WATER COMMISSION
DATE: 12-17-87

ALVORD, BURDICK & HOWSON
ENGINEERS
CHICAGO

EXHIBIT B-2
COMMISSION CONNECTION FACILITIES

Village of Montgomery
Water Purchase and Sale Contract

EXHIBIT B-2 COMMISSION CONNECTION FACILITIES

TYPICAL 3-TRAIN METER STATION LAYOUT

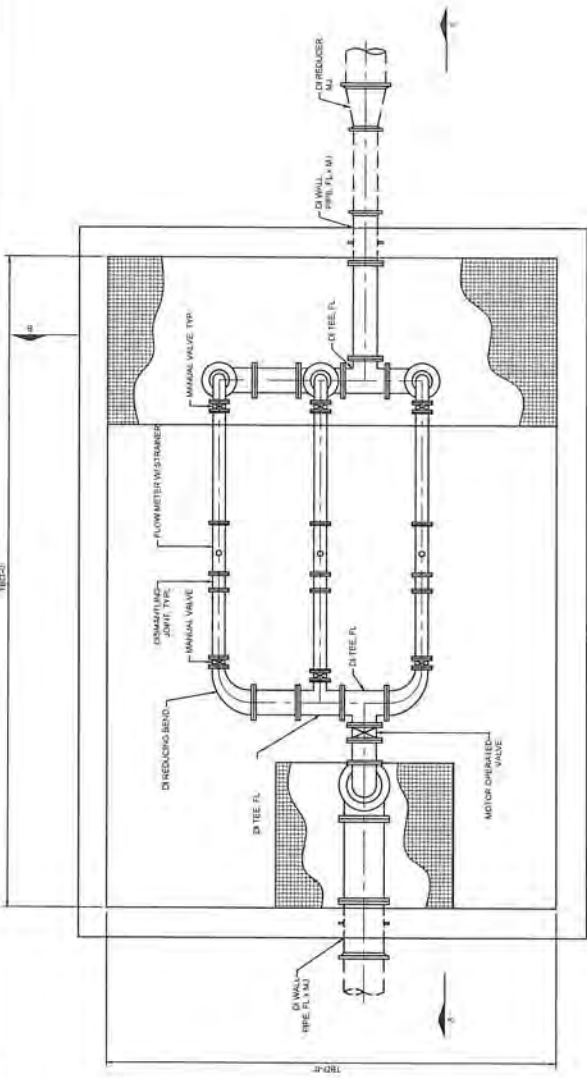

PLAN VIEW

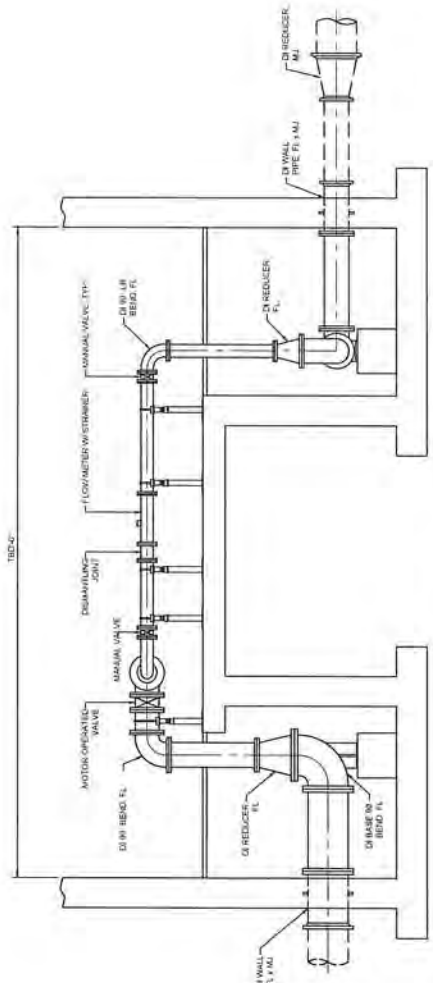

SECTION A-A

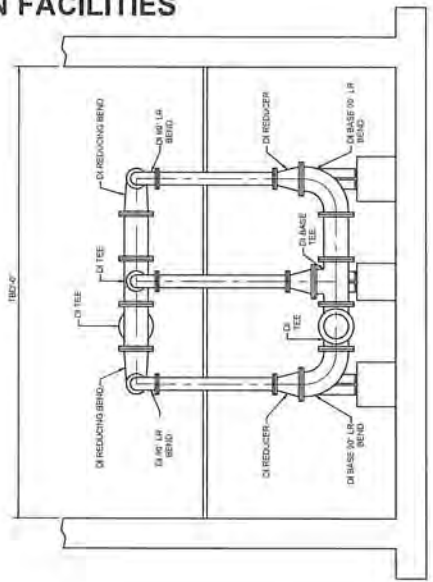

SECTION B-B

REV	DATE	DESCRIPTION	BY	DATE	CHECKED	SCALE	PROJECT NO.

DESIGNED	MJD	CHECKED	JWS	DRAWN	NSZ	PROJECT NO.	024.10001.001

DESIGNED	MJD	CHECKED	JWS	DRAWN	NSZ	PROJECT NO.	024.10001.001

DRAWING NO.	D-102	SHEET NO.	2	OF	2
-------------	-------	-----------	---	----	---

TYPICAL 3-TRAIN
METER STATION
PRELIMINARY PIPING LAYOUT

DUPAGE WATER COMMISSION
WATERLINK EXTENSION



EXHIBIT C
MONTGOMERY UNIT SYSTEM STORAGE REQUIREMENTS

EXHIBIT E
MONTGOMERY WATER STORAGE REQUIREMENTS

CUSTOMER	CUSTOMER EXISTING STORAGE (MG)	2030 ALLOCATION (MGD)	ALLOCATION AS A PERCENTAGE OF SYSTEM	STORAGE REQUIRED BY CONTRACT (MG)	10% SHALLOW WELL ALLOWANCE (MG)(1)	PORTION OF DWC STORAGE (MG)	STORAGE ABOVE OR (BELOW) REQUIREMENT (MG)
ADDISON	6.75	3.582	4.01%	7.16	0.72	2.51	2.81
ARGONNE	1.60	0.758	0.85%	1.52	0.15	0.53	0.77
BARTLETT	7.50	3.246	3.63%	6.49	0.65	2.27	3.93
BENSENVILLE	3.55	1.907	2.13%	3.81	0.00	1.33	1.07
BLOOMINGDALE	4.80	2.348	2.63%	4.70	0.47	1.64	2.22
CAROL STREAM	6.50	3.667	4.10%	7.33	0.73	2.57	2.46
IAWC ARROWHEAD	0.40	0.145	0.16%	0.29	0.03	0.10	0.24
IAWC COUNTRY CLUB	0.20	0.105	0.12%	0.21	0.02	0.07	0.08
IAWC DU PAGE/LISLE	0.76	0.470	0.53%	0.94	0.09	0.33	0.24
IAWC LOMBARD	0.05	0.050	0.06%	0.10	0.01	0.03	(0.01)
IAWC VALLEY VIEW	0.88	0.520	0.58%	1.04	0.10	0.36	0.31
IAWC LIBERTY RIDGE WEST	0.40	0.300	0.34%	0.60	0.06	0.21	0.07
IAWC LIBERTY RIDGE EAST	0.05	0.030	0.03%	0.06	0.01	0.02	0.02
CLARENDON HILLS	1.25	0.818	0.92%	1.64	0.16	0.57	0.35
DARIEN /DPC-SERWF	4.00	3.269	3.66%	6.54	0.65	2.29	0.40
DOWNERS GROVE	8.00	6.097	6.82%	12.19	1.22	4.27	1.29
DuPAGE COUNTY	2.63	1.483	1.66%	2.97	0.30	1.04	1.00
ELMHURST	15.00	4.083	4.57%	8.17	0.82	2.86	10.51
GLENDALE HEIGHTS	4.70	2.671	2.99%	5.34	0.53	1.87	1.76
GLEN ELLYN	3.25	2.562	2.87%	5.12	0.51	1.79	0.43
HINSDALE	4.50	2.468	2.76%	4.94	0.49	1.73	1.78
ITASCA	3.50	1.486	1.66%	2.97	0.30	1.04	1.86
LISLE	5.50	2.686	3.01%	5.37	0.54	1.88	2.54
LOMBARD	5.60	4.174	4.67%	8.35	0.83	2.92	1.01
MONTGOMERY (2)	5.50	2.112	2.36%	4.22	0.42	1.48	3.18
NAPERVILLE	43.90	17.454	19.54%	34.91	3.49	12.21	24.69
OAK BROOK	8.00	3.294	3.69%	6.59	0.66	2.30	4.38
OAKBROOK TERRACE	0.50	0.261	0.29%	0.52	0.05	0.18	0.21
ROSELLE	1.75	1.866	2.09%	3.73	0.37	1.31	(0.30)
VILLA PARK	3.80	1.784	2.00%	3.57	0.00	1.25	1.48
WESTMONT	4.50	2.552	2.86%	5.10	0.51	1.79	1.69
WHEATON	7.26	4.846	5.42%	9.69	0.97	3.39	1.93
WILLOWBROOK	4.00	1.031	1.15%	2.06	0.21	0.72	2.87
WINFIELD	1.60	0.916	1.03%	1.83	0.18	0.64	0.59
WOOD DALE	3.35	1.244	1.39%	2.49	0.25	0.87	1.98
WOODRIDGE	6.15	3.058	3.42%	6.12	0.61	2.14	2.78
CUSTOMER TOTAL STORAGE	181.68	89.343	100.00%	178.69	17.13	62.50	82.62
DWC SYSTEM STORAGE	62.50						
TOTAL CUSTOMER AND DWC STORAGE	244.18						

(1) Customer Shallow Well Allowance and Storage Requirements are audited annually for compliance.

(2) As Montgomery is not scheduled to take water until 2032, the Montgomery 2032 IDNR Allocation has been utilized for these calculations. Montgomery is currently in preliminary design for two additional 1.0 MG Ground Level Storage Tanks.

EXHIBIT D
METER STATION AND ACCESS EASEMENTS

Village of Montgomery
Water Purchase and Sale Contract

EXHIBIT D
METER STATION AND ACCESS EASEMENTS
(FORM OF)

DUPAGE WATER COMMISSION

METERING STATION

EASEMENT AGREEMENT

[Meter Station Name]

[PERMANENT REAL ESTATE TAX INDEX NO. XX-XX-XXX-XXX]

Prepared by and Mail to:

Paul D. May, PE
General Manager
DuPage Water Commission
600 East Butterfield Road
Elmhurst, Illinois 60126-4642
630-834-0100

METERING STATION
EASEMENT AGREEMENT
[Meter Station Name]

THIS EASEMENT AGREEMENT, made and entered into this ____ day of _____, 202_, by and between the DUPAGE WATER COMMISSION, a county water commission created and existing under the laws of the State of Illinois (the "Commission") and the ***[MUNICIPALITY]***, a unit of local government created and existing under the laws of the State of Illinois and a customer of the Commission (the "Customer"),

W I T N E S S E T H:

WHEREAS, the Commission and the Customer have entered into a certain Water Purchase and Sale Contract dated as of October 17, 2024 (the "Contract"); and

WHEREAS, the Contract provides that the Commission is to furnish, install, own, operate, maintain, and repair certain equipment and devices, together with certain structures and portions of its water distribution main, including underground feeder pipeline and related equipment, for properly conveying and measuring the quantity of Lake Michigan water delivered by the Commission to the Customer at the connection point provided for under the Contract (collectively referred to as the "Metering Station"); and

WHEREAS, the Contract provides that the Metering Station is to be located at a site selected and provided by the Customer, subject to review and approval by the Commission; and

WHEREAS, the Customer has selected the site legally described in Exhibit 1 attached hereto and by this reference incorporated herein and made a part hereof (the "Metering Station Easement Premises") for the location of the Metering Station as

generally depicted in Exhibit 2 attached hereto and by this reference incorporated herein and made a part hereof; and

WHEREAS, the Commission has reviewed the Metering Station Easement Premises and approved the same for the location of the Metering Station; and

WHEREAS, the Commission has submitted to the Customer for review the drawings and specifications for the Metering Station; and

WHEREAS, the Commission and the Customer desire to enter into this Easement Agreement in order to provide the Commission with a sufficient property interest in the Metering Station Easement Premises to fulfill the provisions and purpose of the Contract;

WHEREAS, the Commission has duly adopted its Ordinance No. **[O-XX-XX]**, being "An Ordinance Requesting the Intergovernmental Transfer of Easement Rights for the **[Municipality]** Metering Station MS-**[XXX]** Site and Authorizing the Execution of the **[Municipality]** Metering Station Easement Agreement," pursuant to the Local Government Property Transfer Act, 50 ILCS 605/0.01 et seq.; and

WHEREAS, the Customer has duly adopted its Resolution No. **[TBD]**, being "A Resolution Approving the Intergovernmental Transfer of Easement Rights to the DuPage Water Commission," pursuant to the Local Government Property Transfer Act, 50 ILCS 605/0.01 et seq.;

NOW, THEREFORE, in consideration of the foregoing and for other good and valuable consideration, the receipt and sufficiency of which is hereby acknowledged, and in the exercise of their powers and authority under the intergovernmental cooperation provisions of Article VII, Section 10 of the Illinois Constitution of 1970 and the Intergovernmental Cooperation Act, 5 ILCS 220/1 et seq., and other applicable authority, the Commission and the Customer hereby agree as follows:

1. The foregoing recitals are hereby incorporated herein as substantive provisions of this Easement Agreement.

2. The Customer hereby grants, conveys, warrants, and dedicates to the Commission, its successors and assigns, an exclusive perpetual easement to construct, furnish, install, own, operate, maintain, test, inspect, remove, repair, and replace the Metering Station at, in, under, and upon the Metering Station Easement Premises, together with all reasonable rights of ingress and egress along or across any adjoining lands of, or under the jurisdiction and control of, the Customer. The Customer hereby further grants, conveys, warrants, and dedicates to the Commission, its successors and assigns, a non-exclusive perpetual access easement along and across the real property legally described in Exhibit 1 attached hereto and by this reference incorporated herein and made a part hereof (the "Access Easement Premises"). The Customer hereby further grants, conveys, warrants, and dedicates to the Commission, its successors and assigns, a non-exclusive perpetual utility access easement along and across the real property legally described in Exhibit 1 attached hereto and by this reference incorporated herein and made a part hereof (the "Utility Access Easement Premises").

3. The Metering Station shall be not located, constructed, or maintained in any manner not in substantial conformity with Exhibit 2 without the express consent of the Customer, which consent shall not be unreasonably withheld.

4. The Customer hereby further grants to the Commission a temporary construction easement for the installation of the Metering Station upon, along, and across the real property legally described in Exhibit 3 attached hereto and by this reference incorporated herein and made a part hereof (the "Subject Property"). Said temporary construction easement shall be used by the Commission only during periods of actual

installation, replacement or repair activity and for any necessary restoration of the Metering Station Easement Premises.

5. The Commission shall exercise the easement rights hereby granted with due care, and shall not unreasonably interfere with, damage, or harm any Customer property located upon the Subject Property or Customer's adjacent property.

6. After construction of the Metering Station, the Metering Station Easement Premises shall be restored in accordance with the drawings and specifications for the Metering Station. All fences, roads, landscaping, and improvements shall be restored to former condition by the Commission if disturbed or altered in any manner by construction or maintenance activities of the Commission.

7. The Customer hereby reserves the right to use the Metering Station Easement Premises, the Access Easement Premises, the Utility Access Easement Premises, and its adjacent property in any manner that will not prevent or interfere in any way with the exercise by the Commission of the rights granted hereunder; provided, however, that the Customer shall not in any manner disturb, damage, destroy, injure, obstruct, or permit to be obstructed the Metering Station Easement Premises, the Access Easement Premises, or the Utility Access Easement Premises without the express prior written consent of the Commission, nor shall the Customer permanently or temporarily improve, damage, or obstruct the Metering Station Easement Premises, the Access Easement Premises, or the Utility Access Easement Premises in any manner that would impair the exercise by the Commission of the rights hereby granted.

8. To the fullest extent permitted by law, the Customer agrees to indemnify and defend the Commission with respect to any and all claims or damages to persons or property which may arise from the acts of the Customer, or its agents or employees, at

the Metering Station Easement Premises, the Access Easement Premises, the Utility Access Easement Premises, the Subject Property, and its adjacent property in conjunction with its rights pursuant to Paragraph 7 hereof, and, except as otherwise provided in the Contract, the Commission agrees to indemnify and defend the Customer with respect to any and all claims of damages to persons or property which may arise from the of the Commission, or its agents or employees, at the Metering Station Easement Premises, the Access Easement Premises, the Utility Access Easement Premises and the Subject Property in conjunction with its rights pursuant to Paragraphs 2, 4, 5 and 7 hereof. The Customer shall provide to the Commission, and the Commission shall provide to the Customer, a certificate of insurance or proof of self-insurance coverage as evidence of its continuing ability to meet the obligation established in this Paragraph, and both shall maintain such coverage at all times.

9. This Easement Agreement shall constitute and stand in the place of all Customer permits required of the Commission or its contractor to construct, furnish, install, own, operate, maintain, test, inspect, repair, remove, or replace the Metering Station at, in, under, and upon the Metering Station Easement Premises, and the Customer hereby agrees to execute any and all additional documents, approvals, waivers, or consents, if any, that may be reasonably necessary for the Commission to secure any permits required from any county, state, or federal agency for or in connection with constructing, furnishing, installing, owning, operating, maintaining, testing, inspecting, repairing, removing, or replacing the Metering Station.

10. In the event that the Contract is terminated without renewal with respect to the Customer, the Commission shall, within 90 days execute and deliver to the Customer an appropriate document evidencing the termination of this Easement Agreement and

releasing the easement rights hereby granted. The Commission may, within said 90 day period, in its own discretion, and at the Customer's expense, remove the Metering Station from the Metering Station Easement Premises. If the Commission fails to remove the **[Municipality]** Metering Station, as aforesaid, the Customer may take title to the Metering Station.

11. All rights, title, and privileges herein granted, including all benefits and burdens, shall run with the land and shall be binding upon and inure to the benefit of the parties hereto and their respective grantees, successors, assigns, and legal representatives.

12. All representations and warranties contained herein shall survive the execution of this Easement Agreement and the recordation hereof and shall not be merged.

IN WITNESS WHEREOF, the parties hereto have caused this instrument to be executed by their proper representatives duly authorized to execute the same.

DUPAGE WATER COMMISSION

ATTEST:

By: _____
Paul May, PE
General Manager

Danna Mundall
Clerk

[MUNICIPALITY]

By: _____
[NAME]
[Village/City President/Mayor]

ATTEST:

By: _____

Its: _____

EXHIBIT 1

LEGAL DESCRIPTIONS OF THE
METERING STATION EASEMENT PREMISES

PERMANENT METER STATION EASEMENT:

[INSERT LEGAL DESCRIPTION PROVIDED BY CUSTOMER]

PERMANENT ACCESS EASEMENT:

[INSERT LEGAL DESCRIPTION PROVIDED BY CUSTOMER]

EXHIBIT 1

LEGAL DESCRIPTIONS OF THE
METERING STATION EASEMENT PREMISES

PERMANENT UTILITY ACCESS EASEMENT:

[INSERT LEGAL DESCRIPTION PROVIDED BY CUSTOMER]

EXHIBIT 2

PLANS FOR METERING STATION

[PROVIDED BY THE COMMISSION]

EXHIBIT 2-A

MS ELEVATION DRAWINGS

[PROVIDED BY THE COMMISSION]

EXHIBIT 2-B

MS FLOOR PLANS

[PROVIDED BY THE COMMISSION]

EXHIBIT 2-C

MS SECTION DRAWINGS

[PROVIDED BY THE COMMISSION]

EXHIBIT 3

LEGAL DESCRIPTION OF THE TEMPORARY CONSTRUCTION
EASEMENT PREMISES

TEMPORARY CONSTRUCTION EASEMENT:

[INSERT LEGAL DESCRIPTION PROVIDED BY CUSTOMER]

STATE OF ILLINOIS)
) SS
COUNTY OF COOK)

I, _____, a Notary Public in and for said County, in the State aforesaid, do hereby certify that Paul D. May, personally known to me to be the General Manager of the DuPage Water Commission, and Danna M. Mundall, personally known to me to be the Clerk of the DuPage Water Commission, and personally known to me to be the same persons whose names are subscribed to the foregoing instrument, appeared before me this day in person and acknowledged that he/she signed, sealed, and delivered said instrument as his/her free and voluntary act, and as the free and voluntary act of said Commission, for the uses and purposes therein set forth.

Given under my hand and official seal this _____ day of _____, 202_.

Notary Public

My Commission Expires: _____

STATE OF ILLINOIS)
) SS
COUNTY OF [])

I, _____, a Notary Public in and for said County, in the State aforesaid, do hereby certify that **[Name]**, personally known to me to be the **[Title]** of the **[Municipality]**, and _____, personally known to me to be the _____ of the Village of Oswego, and personally known to be the same persons whose names are subscribed to the foregoing instrument, appeared before me this day in person and acknowledged that they signed, sealed, and delivered said instrument as their free and voluntary act, and as the free and voluntary act of said Village, for the uses and purposes therein set forth.

Given under my hand and official seal this _____ day of _____, 202_.

Notary Public

My Commission Expires: _____

EXHIBIT E
CAPITAL COST RECOVERY CHARGE

Village of Montgomery
Water Purchase and Sale Contract

EXHIBIT E
CAPITAL COST RECOVERY CHARGE

DuPage Water Commission
Calculation of Capital Cost Recovery Charge as of May 1, 2024
For Montgomery

Fixed Assets (Audited as of 04-30-2024)	
Land	\$ 11,728,902
Infrastructure	383,618,530
Buildings	110,194,197
Office Equipment	4,763,332
Machinery	27,061,530
Vehicles	1,055,314
CIP	15,415,869
Total	\$553,837,674
Less: Feeder Mains & Meter Stations	94,321,158
	459,516,516
Less: Total Rebates	106,326,287
Total	\$353,190,229

		Total Capital Cost Recovery Charge	
	MGD		
Oswego (CY2022-CY2023 Avg)	2.505	3.128%	\$ 11,047,790
Montgomery (CY2022-CY2023 Avg)	2.267	2.831%	\$ 9,998,815
Yorkville (CY2022-CY2023 Avg)	1.817	2.269%	\$ 8,013,886
DuPage Water Commission (CY2022-CY2023 Avg)	73.483		
	Total		\$ 29,060,491

EXHIBIT F
SCHEDULE OF EVENTS

Village of Montgomery
Water Purchase and Sale Contract

EXHIBIT F

MONTGOMERY ILLUSTRATIVE SCHEDULE OF EVENTS

WEEKS>>	0	26	185	208
I. MONTGOMERY DUTIES A. Property Interests <hr/> B. Montgomery Connection Facilities <hr/> C. Water Storage Facilities (Not Applicable)	(CONTRACT SIGNED) Commence acquisition of necessary interests (Section 10G)	Convey all required easements and interests to DWC (Section 10G)		
				Submit plans and specs for DWC review (Section 10A)
II. DWC DUTIES A. Property Interests <hr/> B. Commission Connection Facilities		Commence Design upon receipt of all required easements and interests (Section 10H)	Complete Construction of Commission Connection Facilities (May 1, 2028)	
III. OTHER EVENTS A. Delivery of Water <hr/> B. Payment of Costs other than O&M <hr/> C. Payment of O&M Costs				
				Montgomery's First payment due at 1st billing cycle after substantial completion of Commission Connection Facilities (Section 7M)

EXHIBIT F

MONTGOMERY ILLUSTRATIVE SCHEDULE OF EVENTS

WEEKS>>	212	224	225	237
I. <u>MONTGOMERY DUTIES</u> A. Property Interests <hr/> B. Montgomery Connection Facilities <hr/> C. Water Storage Facilities (Not Applicable)	 DWC completes review (Section 10A) 	 Complete design of Customer Connection Facilities (Section 10A) 	 Submit for IEPA and local approvals (Section 10B) 	 Projected IEPA and local approvals
II. <u>DWC DUTIES</u> A. Property Interests <hr/> B. Commission Connection Facilities	 	 	 	
III. <u>OTHER EVENTS</u> A. Delivery of Water <hr/> B. Payment of Costs other than O&M <hr/> C. Payment of O&M Costs	 	 	 	

EXHIBIT F

MONTGOMERY ILLUSTRATIVE SCHEDULE OF EVENTS

WEEKS>>	244	338	415
I. <u>MONTGOMERY DUTIES</u> A. Property Interests ----- B. Montgomery Connection Facilities ----- C. Water Storage Facilities (Not Applicable)	----- Commence construction of Customer Connection Facilities (Section 10C) -----	----- Complete construction of Customer Connection Facilities (Section 10C) -----	----- ----- -----
II. <u>DWC DUTIES</u> A. Property Interests ----- B. Commission Connection Facilities	----- ----- -----	----- ----- -----	----- ----- -----
III. <u>OTHER EVENTS</u> A. Delivery of Water ----- B. Payment of Costs other than O&M ----- C. Payment of O&M Costs	----- ----- -----	----- ----- -----	Commence Delivery of Lake Water (October 1, 2032) ----- Montgomery's First payment due at 1 st billing cycle after earlier of delivery of water or 12 months after Commission Connection Facilities substantially completed. (Section 7M) -----

EXHIBIT G
WATERLINK PROJECT ESCROW INTERGOVERNMENTAL AGREEMENT

Village of Montgomery
Water Purchase and Sale Contract

**WATERLINK PROJECT
ESCROW INTERGOVERNMENTAL AGREEMENT**

This WaterLink Project Escrow Intergovernmental Agreement (the “WaterLink Project Escrow Agreement” or this “Agreement”)) is dated the 17th day of October 2024 between the Village of Montgomery (“Montgomery”), the Village of Oswego (“Oswego”), and the United City of Yorkville (“Yorkville”) (Oswego, Montgomery, and Yorkville are collectively referred to herein as the “WaterLink Communities”) and the DuPage Water Commission (the “Commission”), a county water commission and public corporation under Division 135 of Article 11 of the Illinois Municipal Code, 65 ILCS 5/11-135-1 *et seq.*, and the Water Commission Act of 1985, 70 ILCS 3720/0.01 *et seq.* (the “Acts”).

WITNESSETH:

WHEREAS, the Commission has been organized under the Acts to supply water within its territorial limits; and

WHEREAS, the WaterLink Communities currently own and operate municipal drinking water systems served by wells that extract source water from the Ironton-Galesville aquifer; and

WHEREAS, the WaterLink Communities are within the territorial limits of the Commission; and

WHEREAS, the WaterLink Communities intend to change from the Ironton-Galesville groundwater source to Lake Michigan source water, through water purchase and sale agreements with the Commission, and have applied for and been awarded Lake Michigan Water Allocation Permits from the State of Illinois Department of Natural Resources, Office of Water Resources for each discrete and non-contiguous service area served by each WaterLink Community’s Unit System (“Service Area”); and

WHEREAS, the WaterLink Communities have conducted extensive study and have concluded that the most sustainable alternative water source to serve the WaterLink Communities through the municipal waterworks systems currently serving the WaterLink Communities, as well as any extensions or improvements of those systems, is Lake Michigan water from the Commission; and

WHEREAS, the Commission owns and maintains a waterworks system as a supplier of Lake Michigan water to member customers that contract for such service (“Commission’s Waterworks System”); and

WHEREAS, the parties seek to complete the improvements necessary to connect the Commission’s Waterworks System to the WaterLink Communities’ individual Unit Systems in 2028; and

WHEREAS, the Commission has entered into a Water Supply Contract with the City of Chicago to purchase Lake Michigan water sufficient to meet the water supply needs of the Commission and its customers; and

WHEREAS, the Commission’s Water Supply Contract with the City of Chicago is set to expire in 2041, and the Commission is currently: (1) exploring an alternative solution to obtaining Lake Michigan water; and (2) in discussions and negotiations with the City of Chicago for a new Water Supply Contract; and

WHEREAS, to carry out their duties and responsibilities, and desire to create a method of providing an adequate supply of Lake Michigan water to the Service Area, the Commission and each of the WaterLink Communities, contemporaneously with this Agreement are entering into Water Purchase and Sale Contracts (the “Water Purchase Agreements”) and this Agreement incorporates the defined terms of the Water Purchase Agreements unless otherwise specified herein; and

WHEREAS, to become a member of the Commission and comply with the Water Purchase Agreements, each WaterLink Community must pay its proportional share of the costs for the property owned by the Commission; and

WHEREAS, contemporaneously with this Agreement, the WaterLink Communities and the Commission are each entering into a Capital Cost Recovery Agreements that establish the terms and conditions for financing each WaterLink Community’s proportional share of the costs for the property owned by the Commission; and

WHEREAS, contemporaneously with this Agreement, each WaterLink Community and the Commission are entering into an Intergovernmental Agreement Concerning the Development of Connection Facilities to Implement Water Service (the "Development Agreement"); and

WHEREAS, the WaterLink Communities intend that certain provisions within this Agreement be used only to the extent that one or all of the WaterLink Communities have failed to properly fund this Agreement after notice has been provided in accordance with this Agreement; and

WHEREAS, the Commission will incur in connection with (i) the design, bidding, contracting, managing, and actual construction, installation, removal, relocation, replacement, extension, or improvement of the Connection Facilities, including without limitation equipment required for the operation of the Connection Facilities and all administrative, financing, supervisory, inspection, engineering, surveying, and legal fees, costs, and expenses associated therewith; (ii) the acquisition and divestment of lands, easements, and rights of way over lands and waters necessary for the construction, installation, removal, relocation, replacement, extension, or improvement of the Connection Facilities, and all administrative, title, surveying, and legal fees, costs, and expenses associated therewith; and (iii) the review and processing of plans and agreements for the construction, installation, removal, relocation, replacement, extension, or improvement of the Connection Facilities and in connection with the negotiation, preparation, consideration, and review of this Contract, including without limitation all legal, engineering, consulting, and administrative fees, costs, and expenses associated therewith; except as any of the above are included in Operation and Maintenance Costs ("Connection Facilities Cost"); and

WHEREAS, the Commission and the WaterLink Communities have previously entered into First and Second Escrow Intergovernmental Agreements (the "Prior Escrow Agreements") for what is defined under those Prior Escrow Agreements as Phase I and Phase 2 Services; and

WHEREAS, prior to the execution of documents requiring the expenditure of Commission Expenses, the Commission requires the WaterLink Communities to establish an additional escrow fund with the Commission as stated herein to provide a funding source for the Commission Expenses beyond those incurred for the Phase 1 and Phase 2 Services; and

WHEREAS, pursuant to the Development Agreement, the WaterLink Communities will be responsible for the Connection Facilities Cost; and

WHEREAS, the WaterLink Communities have previously agreed to each Municipality's percentage share of the Connection Facilities Cost pursuant to an Intergovernmental Cost Share Agreement (the "Cost Share Agreement"). The WaterLink Communities agree that the costs paid into the escrow account under this WaterLink Project Escrow Agreement will mirror the Division of Financial Responsibilities/Allocation of Costs set forth in the Cost Share Agreement. Specifically, Montgomery commits and agrees to pay 24.42%, Yorkville commits and agrees to pay 40.22%, and Oswego commits and agrees to pay 35.36%. The Commission is not a party to the Cost Share Agreement and has no responsibility or liability as to any true-up or adjusted accounting between the WaterLink Communities; and

WHEREAS, pursuant to Article VII, Section 10 of the Illinois Constitution of 1970, and the Intergovernmental Cooperation Act, 5 ILCS 220/1 et seq., the Commission and the WaterLink Communities are authorized to enter into this WaterLink Project Escrow Agreement.

NOW, THEREFORE, in consideration of the foregoing recitals and of the mutual covenants and agreements herein contained, the WaterLink Communities and the Commission hereby agree as follows:

1. The foregoing recitals are by this reference incorporated herein and made a part hereof as if fully set forth herein. Further, to the extent any capitalized terms in this Agreement are set forth as a defined term in the Water Purchase Agreements, the capitalized terms in this Agreement shall have the same meaning in this Agreement as the definition in the Water Purchase Agreements.

2. The Commission will establish a segregated escrow account for the sole purpose of funding the Connection Facilities Cost (the "Waterlink Project Escrow Account"). The WaterLink Communities will each deposit into the Waterlink Project Escrow Account all payments necessary to fund the Connection Facilities Cost. Any remaining funds from the prior Escrow Agreements will remain in the related escrow account, and any funds not expended or necessary for Phase I and Phase II Services, when those phases are complete, may be transferred

to the WaterLink Project Escrow Account, unless otherwise directed by the WaterLink Communities.

3. The Commission will draw from the WaterLink Project Escrow Account to pay for or reimburse any Connection Facilities Cost incurred.

4. The WaterLink Project Escrow Account will be insured and interest-bearing, and the Commission will provide the WaterLink Communities with Quarterly Statements within twenty-one (21) days after the end of each quarter: (1) showing the starting and ending balances for that quarter in the WaterLink Project Escrow Account; and (2) detailing the costs of Connection Facilities Cost incurred for that quarter including any amounts received or paid from the WaterLink Project Escrow Account. The WaterLink Communities will have the right to conduct audits for three years after the termination of this WaterLink Project Escrow Agreement relative to the WaterLink Project Escrow Account.

5. The Commission will keep a record of all pay requests from the WaterLink Project Escrow Account for reimbursement of Connection Facilities Cost incurred (the "Pay Request") and sufficient documentation of the Connection Facilities Cost incurred in support of the Pay Request. The documentation will be retained for review by the WaterLink Communities upon request and included within the Quarterly Statements issued by the Commission.

If at any time during the term of this WaterLink Project Escrow Agreement, the balance in the WaterLink Project Escrow Account is less than Thirty Million Dollars (\$30,000,000.00) (the "Minimum Balance Amount"), the Commission will notify the WaterLink Communities. Within thirty (30) days of the Commission notifying the WaterLink Communities under this Paragraph 5, the WaterLink Communities will each pay the Commission its proportionate share (as set forth in the Cost Share Agreement) of the request to ensure that the Minimum Balance is met. Failure to make such payment when required under this Paragraph 5 shall be considered a default of this Agreement by the WaterLink Communities.

6. The Commission will, after the execution and delivery of this Agreement, make available as a line of credit to the WaterLink Communities an amount not to exceed \$21,000,000

(the "Commitment Amount") to pay a portion of the Connection Facilities Cost as defined in the Water Purchase Agreements. The actual amounts of money borrowed by each of the WaterLink Communities pursuant to the Commitment Amount will constitute the "Line of Credit."

7. The WaterLink Communities will repay the principal balance of the Line of Credit, plus accrued and unpaid interest at the Interest Rate set forth in Paragraph 8 of this Agreement from the Interest Commencement Date through the Line of Credit Payment Commencement Date (the "Capitalized Interest"), as those terms are hereinafter defined on the unpaid principal balance, and any Capitalized Interest, of the Line of Credit from and after the Line of Credit Payment Commencement Date, as that term is hereinafter defined, in 240 monthly installments, commencing on the 10th day of every month (the "Monthly Payment Date") commencing on the Line of Credit Payment Commencement Date as hereafter defined in Paragraph 9 and continuing in successive monthly installments on each Monthly Payment Date in each month thereafter, with the final payment of any unpaid interest and principal, if not sooner paid, on the 240th Monthly Payment Date. Each of the 240 monthly installments of principal on the Line of Credit will be determined as of the last day of the month preceding the Monthly Payment Date in any given year during the term of the Line of Credit (a "Principal Determination Date") and will be determined by dividing the unpaid principal balance, and any Capitalized Interest, of the Line of Credit as of the applicable Principal Determination Date by the number of monthly installments of principal remaining to be paid during the term of the Line of Credit. The accrued and unpaid interest will be capitalized on a monthly basis until the Line of Credit Payment Commencement Date. There will be no penalty for prepayment.

8. Interest on the unpaid principal balance, and any Capitalized Interest, of the Line of Credit will accrue at a rate (the "Interest Rate") that is equivalent to the highest yield to maturity interest rate earned by the Commission (based on all investments) as reported monthly on the Commission's Schedule of Investments for the immediately preceding fiscal year (May 1 – April 30) as determined by the Commission (the "Earned Interest Rate") plus one percent (1%). Interest will only accrue on money actually borrowed under Paragraph 6 of this Agreement and will begin to accrue when the Commission makes its first draw on the Line of Credit for the WaterLink Communities (the "Interest Commencement Date"). The Interest Rate for each year that the Line

of Credit remains outstanding will be calculated on the basis of a calendar year consisting of 360 days of twelve 30-day months and will be adjusted on May 1st of each year, and will be applied to the outstanding unpaid principal balance, and any Capitalized Interest, as determined on the most recent Principal Determination Date, will be paid commencing on the Monthly Payment Date, and continuing on the Monthly Payment Date each month thereafter until the principal balance of the Line of Credit and all interest thereon has been paid in full.

9. Payments of principal and interest, including Capitalized Interest, will begin no later than the 10th day of the first month after the first delivery of potable, filtered water drawn from Lake Michigan to any of the WaterLink Communities individual Unit Systems as that term is defined in the Water Purchase Agreement (the "Line of Credit Payment Commencement Date").

10. Payments of the principal and interest will be made in lawful money of the United States of America in federal or other immediately available funds.

11. If at any time, the Commission receives invoices incurred arising out of the Connection Facilities Cost for which there are insufficient funds in the Construction Escrow Agreement, the Commission will pay the actual costs incurred from the Connection Facilities Cost Line of Credit. The Commission payments for the Connection Facilities Cost will be paid out of the Commitment Amount and will be immediately considered part of the Line of Credit. The Commission may make payments from the Line of Credit no more than once per month, on the 10th day of the month, provided that the Commission will give the WaterLink Communities notice (which notice must be received by the WaterLink Communities prior to 10:00 a.m., local time, 7 days prior to the requested borrowing date), specifying the amount to be paid and the payment date. It is anticipated that only a single borrowing will be requested each month. Each borrowing pursuant to this Agreement will be in an aggregate principal amount less than the Available Commitment. For purposes of this Paragraph 11, the Available Commitment at a particular time is an amount equal to the difference between the Commitment Amount and the aggregate principal balance of the Line of Credit then outstanding.

12. Subject to the limitations of Paragraph 12, the WaterLink Communities may, without premium or penalty, upon at least one business day's irrevocable notice to the

Commission, specifying the date and amount of prepayment, make such prepayment; and the payment amount specified in such notice will be due and payable on the date specified therein. The proceeds of any such prepayment will be applied by the Commission first, to the payment of accrued and unpaid interest, if any, on the Line of Credit, and second, to the payment of the unpaid principal balance of the Line of Credit. The WaterLink Communities will not be entitled to, nor receive any credit for, interest on any such prepayment.

13. The proceeds of the Line of Credit will be devoted to and used with due diligence for the purpose of paying the Connection Facilities Cost identified in Exhibit A; provided, however, that where an unexpended balance remains in any one or more of the various cost components of the Connection Facilities Cost detailed in Exhibit A attached hereto, such balance may be transferred and expended, in whole or in part, to and for any other cost component of the Connection Facilities Cost detailed in Exhibit A attached hereto.

14. The Covenants set forth in Subsections 9A, 9B, 9C, and 9D of the Water Purchase Agreements are incorporated into this Agreement by reference.

15. This WaterLink Project Escrow Agreement will terminate, and any monies not paid or incurred for Connection Facilities Cost, including any interest therein will be returned to the WaterLink Communities, unless mutually agreed to by the WaterLink Communities and the Commission, upon the earlier of:

- a. upon written request by the WaterLink Communities, a written direction that is issued by the General Manager of the Commission that the funds are no longer needed for any Connection Facilities Cost, which direction shall not be unreasonably withheld; or
- b. upon the WaterLink Communities' written notification to the Commission that they are no longer pursuing the purchase of Lake Michigan water from the Commission, and the payment of all the Connection Facilities Cost.

No monies will be returned to the WaterLink Communities until a full accounting has been completed of the expenditures incurred under this WaterLink Project Escrow Agreement.

16. If any WaterLink Community or the Commission defaults in the full and timely performance of any of its obligations hereunder, the non-breaching entity or entities, after first providing written notice to the breaching entity of the event of default and providing the breaching entity ten (10) days to cure the same, will be entitled to invoke its legal rights and remedies as a result thereof, including, but not limited to, its equitable remedy of specific performance. THE FOREGOING NOTWITHSTANDING, NO ENTITY WILL BE LIABLE TO ANOTHER ENTITY OR ANY OF ITS AFFILIATES, AGENTS, EMPLOYEES, OR CONTRACTORS FOR SPECIAL, INDIRECT, EXEMPLARY, INCIDENTAL, PUNITIVE, OR CONSEQUENTIAL DAMAGES.

17. There are no third-party beneficiaries of this WaterLink Project Escrow Agreement and nothing in this WaterLink Project Escrow Agreement, express or implied, is intended to confer on any person other than the Parties hereto (and their respective successors, heirs, and permitted assigns), any rights, remedies, obligations, or liabilities.

18. Any notices under this WaterLink Project Escrow Agreement will be personally delivered, delivered by the deposit thereof in the U. S. Postal Service, postage prepaid, registered, or certified, return receipt requested, or by overnight courier service to the Party at the address listed below or at another address hereafter designated by notice, or by email transmission. Any such notice will be deemed to have been delivered and given upon personal delivery or delivery by a nationally recognized overnight courier service, or deposit with the United States Postal Service or upon receipt of written confirmation that facsimile or email transmission has been successfully completed:

If to the Commission:

Paul D. May, P.E., General Manager
DuPage Water Commission
600 E. Butterfield Road
Elmhurst, IL 60126
Email: may@dpwc.org

With a copy to:

Phillip A. Luetkehans
Luetkehans, Brady, Garner & Armstrong, LLC
105 E. Irving Park Road
Itasca, IL 60143
Email: pal@lbgalaw.com

If to the WaterLink Communities:

Village Administrator
Village of Oswego
100 Parkers Mill
Oswego, IL 60543
Email: info@oswegoil.org

With a copy to:

David J. Silverman
Village Attorney
Mahoney, Silverman, & Cross, LLC
126 South Main Street
Oswego, Illinois 60543

Village Administrator
Village of Montgomery
200 N River Street
Montgomery, IL 60538
Email: zoephel@montgomeryil.org

With a copy to:

Laura M. Julien
Village Attorney
Mickey Wilson, Weiler, Renzi, Lenert, & Julien, PC
140 Municipal Drive
Sugar Grove, IL 60554

City Administrator
United City of Yorkville
800 Game Farm Road
Yorkville, IL 60560
Email: bolson@yorkville.il.us

With a copy to:

Kathleen Field Orr & Associates
Kathleen Field Orr
2024 Hickory Road, Suite 205
Homewood, IL 60430

With a copy to:

Irene Schild Caminer
Caminer Law, LLC
2612 W. Sunnyside Ave.
Chicago, IL 60625
Email: Irene@caminerlaw.com

19. Each WaterLink Community will hold the Commission harmless and defend the Commission from any claims or litigation that arise out of the engineering, construction, property acquisition, and easement acquisitions for the Connection Facilities being constructed for the WaterLink Communities due to one of all of the WaterLink Communities' failure to comply with the payment obligations arising under this WaterLink Project Escrow Agreement.

20. Miscellaneous.

- a. This WaterLink Project Escrow Agreement shall be deemed to supplement the Water Purchase Agreements in connection with the supply of Lake Michigan water to the Waterlink Communities' individual Unit Systems. If there is any other conflict or inconsistency between the terms of this Agreement and the terms of the Water Purchase Agreements, then the terms of this WaterLink Project Escrow Agreement shall control. The WaterLink Communities shall at all times comply with all terms and conditions of the Water Purchase Agreements except as otherwise provided in this Agreement.

- b. Except as provided herein, the WaterLink Communities and the Commission will not assign this WaterLink Project Escrow Agreement or any right or privilege any WaterLink Communities and the Commission may have under this WaterLink Project Escrow Agreement without the prior written consent of all Parties hereto, not to be unreasonably withheld conditioned or delayed.
- c. This WaterLink Project Escrow Agreement shall be governed by and construed exclusively under the applicable laws, but not the conflict of laws rules, of the State of Illinois. Venue for any litigation arising out of this Agreement shall only be proper in the Eighteenth Judicial Circuit Court, DuPage County, Illinois.
- d. The person(s) executing this WaterLink Project Escrow Agreement on behalf of the Parties hereto warrant that: (i) each WaterLink Community and the Commission are duly organized and existing; (ii) the individual signing is duly authorized to execute and deliver this WaterLink Project Escrow Agreement on behalf of said WaterLink Community or the Commission; (iii) by so executing this WaterLink Project Escrow Agreement, such WaterLink Community and the Commission are formally bound to the provisions and conditions contained in this WaterLink Project Escrow Agreement; and (iv) the entering into this WaterLink Project Escrow Agreement by a WaterLink Community and the Commission does not violate any provision of any other agreement to which said WaterLink Community and the Commission is bound.
- e. Each WaterLink Community and the Commission acknowledge that it may be necessary to execute documents other than those specifically referred to herein in order to complete the objectives and requirements that are set forth in this WaterLink Project Escrow Agreement. Each WaterLink Community and the Commission hereby agree to cooperate with each other by executing such other documents or taking such other actions as may be reasonably necessary to complete the objectives and requirements set forth herein in accordance with the intent of each WaterLink Community and the Commission as evidenced by this WaterLink Project Escrow Agreement.

- f. This WaterLink Project Escrow Agreement is the entire agreement between the WaterLink Communities and the Commission regarding its subject matter and may not be changed or amended except pursuant to a written instrument signed by each WaterLink Community and the Commission.
- g. This WaterLink Project Escrow Agreement may be executed in any number of identical counterparts, each of which will be considered an original, but which together will constitute one and the same agreement.

IN WITNESS WHEREOF, each WaterLink Community and the Commission hereto have caused their respective corporate names to be subscribed hereto and their respective corporate seals to be affixed hereto and attested by their duly authorized officers.

ATTEST:

DuPage Water Commission

BY: _____

ATTEST:

Village of Montgomery

BY: _____

ATTEST:

Village of Oswego

BY: _____

ATTEST:

United City of Yorkville

BY: _____

EXHIBIT A

CONNECTION FACILITIES COST

WATERLINK PROJECT ESCROW INTERGOVERNMENTAL AGREEMENT

EXHIBIT A

CONNECTION FACILITIES COST ESTIMATE (1)

CONSTRUCTION (including 25% contingency)	\$210,389,827
PROPERTY INTERESTS/LAND ACQUISITION	\$17,477,530
LEGAL & ADMINISTRATIVE	\$1,000,000
ENGINEERING	\$28,000,000
	<hr/>
	\$256,867,357
COST ESCALATION OVER PROJECT DURATION	\$26,699,000
	<hr/>
ESTIMATED PROJECT COST (2)	\$283,566,357

(1) COST ESTIMATE IS BASED UPON FORECASTED PROJECT COSTS AS OF THE DATE IDENTIFIED BELOW AND IS PROVIDED FOR REFERENCE ONLY. ACTUAL PROJECT COSTS WILL BE BASED UPON AWARDED PROJECT CONTRACT(S) AND ACTUAL REALIZED UNIT PRICE AND LUMP SUM COSTS, INCLUDING PROPERTY ACQUISITION, ENGINEERING, LEGAL AND COMMISSIONING COSTS, ALL OF WHICH HAVE BEEN ESTIMATED HEREIN BUT WILL NOT BE FINALLY DETERMINED UNTIL THE COMPLETION OF THE PROJECT AND FINAL COMMISSIONING.

(2) BASED UPON ESTIMATES INCLUDED IN THE PROJECT DEVELOPMENT REPORT DATED FEBRUARY 1, 2024



Resolution #: R-60-24, R-61-24, R-62-24, R-63-24, R-64-24, and R-65-24

Account: N/A

Approvals: *Author / Manager / Finance / Admin*

REQUEST FOR BOARD ACTION

Date: 10/9/2024

Description: **Recommendation to Approve Water Purchase and Sales Agreement(s) and Capital Cost Recovery Charge Agreement(s) for the WaterLink communities of Oswego, Yorkville, and Montgomery**

Agenda Section: Administration Committee

Originating Department: Administration

I am pleased to present the WaterLink Customer Agreements for DWC Board consideration. The WaterLink communities have been working toward a new water source for over 10 years after becoming aware of impending water scarcity in the aquifer which provides their current supply. After extended study, the WaterLink partners (Oswego, Montgomery, and Yorkville), identified Lake Michigan source water delivered by the DuPage Water Commission as the preferred future source. This project will be one of the largest water projects in the Midwest, and will extend the DWC service area into Kendall counties with DWC water transmission infrastructure extending west of the Fox River upon completion.

The WaterLink communities have received IDNR allocations and have worked with DWC to fund Phase I and Phase II engineering over the last two years. During this period of time, the WaterLink communities have also been preparing financing instruments to fund the construction of the new infrastructure necessary to be constructed by DWC to convey water to the WaterLink communities. All project costs, including legal, engineering, property acquisition, construction, and commissioning will be funded by the WaterLink communities through a WaterLink Connection Facilities Agreement (R-66-24) and companion Project Escrow agreement (R-67-24), also included on this agenda.

The contract documents presented for approval have been crafted to provide continuity with previously approved Subsequent Customer Agreements to the greatest extent possible. DWC Legal Counsel and staff have worked closely with the WaterLink communities, their staff, and their legal counsel over many months to advance these documents for consideration. I wish to acknowledge and thank them for the significant effort that was provided to complete this task.

A summary of the primary elements of the Agreements is provided following:

Water Purchase and Sales Agreements (R-60-24, R-62-24, R-64-24):

The Water Purchase and Sale Agreement(s) have been constructed to provide a term that matches that of the other Contract Customers, ending February 24, 2064; and include language, terms, and conditions consistent with DWC Contract Customers. The project is scheduled for construction to commence in 2025 and to be commissioned in 2028. WaterLink communities will begin to access the new water source at that time, or as soon as permitted based upon achieving compliance with the IDNR water loss regulations.

Capital Cost Recovery Charge Agreements (R-61-24, R-63-24, R-65-24):

All new (subsequent) DWC customers are required to provide a Capital Cost Recovery Charge (aka “buy-in fee”) to ensure parity with the original Charter Customers which paid for the original DWC system upon formation. The Capital Cost Recovery Charged is determined by computing each customer’s pro-rata share by utilizing their IDNR allocation to calculate their demand as a percentage of the whole, and multiplying that percentage by the value of all DWC fixed assets as of the most recently audited fiscal year (FYE 2024). Based upon these computations, the Capital Cost Recovery Charges to be collected are as follows:

Oswego:	\$11,047,790
Montgomery:	\$ 9,998,815
Yorkville:	\$ 8,013,886

Companion Agreements:

In addition to the 1) Water Purchase and Sale Contract(s) and 2) Capital Cost Recovery Charge Agreement(s) for each of three WaterLink Communities, there are also two additional agreements for which there are four parties/signatories: the Village of Oswego, the Village of Montgomery, the United City of Yorkville, and the DuPage Water Commission. These items are included on the DWC October 17, 2024 DWC Agenda and are listed below:

- Resolution R-66-24: WaterLink Connection Facilities Intergovernmental Agreement
- Resolution R-67-24: WaterLink Project Escrow Agreement

Recommended Motion:

It is recommended that the DWC Board approve the Water Purchase and Sales Agreement(s) and the Capital Cost Recovery Charge Agreement(s) for the WaterLink communities of Oswego, Montgomery, and Yorkville.

DUPAGE WATER COMMISSION

RESOLUTION NO. R-65-24

A RESOLUTION APPROVING AN INTERGOVERNMENTAL AGREEMENT WITH
THE VILLAGE OF MONTGOMERY CONCERNING CAPITAL COST RECOVERY CHARGE

WHEREAS, the Commission was formed and exists pursuant to the Water Commission Act of 1985, 70 ILCS 3720/0.01 et seq., and Division 135 of Article 11 of the Illinois Municipal Code, 65 ILCS 5/11-135-1 et seq., for the purpose of securing an adequate source and supply of water for its customers; and

WHEREAS, the Village of Montgomery (“Montgomery”), the Village of Oswego (“Oswego”) and the United City of Yorkville (“Yorkville”) (Oswego, Montgomery and Yorkville are collectively referred to herein as the “Municipalities”) desire to supply Lake Michigan water to their residents by connecting to the Commission’s waterworks system (the “Project”); and

WHEREAS, the Commission and Montgomery have negotiated an Intergovernmental Agreement Concerning Capital Cost Recovery Charge and a Water Purchase and Sale Contract for the Project; and

WHEREAS, concurrently with the enactment of this Resolution, the Commission and the Municipalities are entering into an Intergovernmental Agreement Concerning Development of Connection Facilities to Implement Water Service for the Project;

WHEREAS, concurrently with the enactment of this Resolution, the Commission and the Municipalities are entering into a WaterLink Project Escrow Intergovernmental Agreement with the Municipalities for the Project; and

WHEREAS, the Commission deems it to be in the best interests of the Commission and the public to complete the Project and enter into the Intergovernmental Agreement with the Village of Montgomery Concerning Capital Cost Recovery Charge.

NOW, THEREFORE, BE IT RESOLVED by the Board of Commissioners of the DuPage Water Commission as follows:

SECTION ONE: The Board of Commissioners of the DuPage Water Commission hereby approves the Intergovernmental Agreement with the Village of Montgomery Concerning Capital Cost Recovery Charge attached hereto as Exhibit 1 and authorizes the Chairman to execute the agreement on behalf of the DuPage Water Commission and to take whatever steps necessary to effectuate the terms of said agreement.

SECTION TWO: This Resolution shall be in full force and effect after passage and approval as required by law.

	Aye	Nay	Absent	Abstain
Bouckaert, D.				
Cuzzone, N.				
Fennell, J.				
VACANT	_____			
Novotny, D.				
Pruyn, J.				
Romano, K.				
Rush, K.				
Russo, D.				
Saverino, F.				
Suess, P.				
Van Vooren, D.				
Zay, J.				

ADOPTED THIS _____ DAY OF _____, 2024.

ATTEST:

James F. Zay, Chairman

Danna Mundall, Clerk

Board/Resolutions/2024/R-65-24.docx

EXHIBIT 1

**INTERGOVERNMENTAL AGREEMENT WITH THE VILLAGE OF MONTGOMERY
CONCERNING CAPITAL COST RECOVERY CHARGE**

This Intergovernmental Agreement, (the “Agreement”) is dated the 17th day of October 2024 (the “Effective Date”), by and between the Village of Montgomery (“Village”) and the DuPage Water Commission (the “Commission”), a county water commission and public corporation under Division 135 of Article 11 of the Illinois Municipal Code, 65 ILCS 5/11-135-1 *et seq.*, and the Water Commission Act of 1985, 70 ILCS 3720/0.01 *et seq.* (the “Acts”).

WITNESSETH:

WHEREAS, the Commission has been organized under the Acts to supply water within its territorial limits; and

WHEREAS, the Village currently owns and operates a municipal drinking water system (“Montgomery Unit System”) served by wells that extract source water from the Ironton-Galesville aquifer; and

WHEREAS, the Village is within the territorial limits of the Commission; and

WHEREAS, the Village intends to change from the Ironton-Galesville groundwater source to Lake Michigan source water, through a Water Purchase and Sale Contract with the DuPage Water Commission, and has applied for and received a Lake Michigan Water Allocation Permit (“Permit”) from the State of Illinois Department of Natural Resources, Office of Water Resources; and

WHEREAS, the Village has conducted extensive study and has concluded that the most sustainable alternative water source to serve the Village through the municipal waterworks system currently serving the Village, as well as any extensions or improvements of that system, is Lake Michigan water from the Commission; and

WHEREAS, the Commission owns and maintains a waterworks system as a supplier of Lake Michigan water to member customers that contract for such service (“Commission’s Waterworks System”); and

WHEREAS, the Village is seeking to obtain water for its residents beginning in or before 2032 from the Commission in the incorporated areas within the Village, as well as nearby unincorporated areas (the “Service Area”); and

WHEREAS, the Village seeks to connect to Lake Michigan through the Commission; and

WHEREAS, the Commission has entered into a water supply contract with the City of Chicago to purchase Lake Michigan water sufficient to meet the water supply needs of the Commission and its customers; and

WHEREAS, the Commission’s water supply contract with the City of Chicago is set to expire in 2041 and the Commission is currently: (1) exploring an alternative solution to obtaining Lake Michigan water; and (2) in discussions and negotiations with the City of Chicago for a new water supply agreement; and

WHEREAS, to carry out their duties and responsibilities, and desire to create a method of providing an adequate supply of Lake Michigan water to the Montgomery Unit System, the Commission, and the Village, concurrent with this Agreement, are entering into the Water Purchase and Sale Contract dated October 17, 2024, WaterLink Project Escrow Intergovernmental Agreement, and an Intergovernmental Agreement Concerning Development of Connection Facilities to Implement Water Service; and

WHEREAS, to become a member of the Commission and comply with the Water Purchase and Sale Contract, the Village must pay its proportional share of the costs for the property owned by the Commission (the “Capital Cost Recovery Charge”); and

WHEREAS, the Commission previously enacted Resolution R-79-04 allowing the Commission the ability to finance the Capital Cost Recovery Charge for potential Subsequent Customers (customers other than its original customers) requesting such accommodation on a case-by case basis; and

WHEREAS, the matters set forth in this Agreement will serve the public interest, and the Commission and the Village deem it to be in each of their best interests for the Commission to provide financing to the Village for the money necessary to pay the Capital Cost Recovery Charge and enter into this Agreement; and

WHEREAS, pursuant to Section 10 of Article VII of the Illinois Constitution of 1970, the provisions of the Intergovernmental Cooperation Act, 5 ILCS 220/1 *et seq.*, and other applicable authority, the Commission and the Village are authorized to enter into this Agreement.

NOW, THEREFORE, in consideration of the foregoing and the mutual covenants and agreements hereinafter set forth, the Commission and the Village hereby agree as follows:

SECTION 1. PREAMBLES

The foregoing recitals are by this reference incorporated herein and made a part hereof as if fully set forth herein.

SECTION 2. COMMISSION FINANCING

A. Capital Cost Recovery Financing. The Commission will, after the execution and delivery of this Agreement, provide financing to the Village in the amount of \$9,998,815.00 (the “Capital Cost Recovery Amount”).

B. Payment Terms.

1. The Village will pay the Commission the principal balance of the Capital Cost Recovery Amount in 360 monthly installments, commencing at the time the first payment is due under Subsection 7M in the Water Purchase and Sale Contract (the “Monthly Payment Date”), and continuing in successive monthly installments on each Monthly Payment Date, with the final payment of any principal, if not sooner paid, on the 360th Monthly Payment Date. Each of the 360 monthly installments of principal for the Capital Cost Recovery Amount will be in the amount of \$27,774.49, except that the final payment will be in the amount of \$27,773.09.
2. Interest on the unpaid principal balance of the Capital Cost Recovery Amount, will accrue at the rate of zero percent (0%) per annum.

C. Tender of Capital Cost Recovery Amount Payments. Payments of the principal of and interest will be made in lawful money of the United States of America in federal or other immediately available funds.

D. Asset-in-Kind Contribution. To the extent the Village agrees to pay for a portion of the increase in size of the primary 48” western pipeline (commencing at Book Road and 75th Street and extending west of the Fox River to a termination point at Orchard Road, also known as “TW 6/25” in the DWC naming convention), from the baseline pipe size to 54”, the value of that contribution by the Village will be mutually agreed upon and set forth in a separate agreement between the Commission and the Village before the closing of the WIFIA Loan.

E. Covenants. The covenants set forth in Subsections 9A, 9B, 9C, and 9D of the Water Purchase and Sale Contract are incorporated into this Agreement by reference.

SECTION 3. DEFAULTS AND REMEDIES

A. Commission Defaults. The occurrence of the following will constitute a default by the Commission under this Agreement: The failure by the Commission to observe and/or perform any covenant, condition, and/or agreement on its part to be observed and/or performed under this Agreement, and the continuation of said failure for thirty (30) days after the Commission's receipt of written notice thereof from the Village. However, if said failure cannot be remedied by the Commission within said thirty (30) day period and the Commission has diligently pursued the resolution of the failure during said thirty (30) days, the period will be extended by such additional time as may be reasonably required by the Commission to cure or correct said failure. In no event will the period be extended by more than ninety (90) days. In the event of a default by the Commission under this Agreement, the Village will have the same remedies as are provided for, and only the remedies provided for, in the Water Purchase and Sale Contract for a default by the Commission.

B. Village Defaults. The occurrence of the following will constitute a default by the Village under this Agreement:

1. The failure by the Village to observe and/or perform any covenant, condition, and/or agreement on its part to be observed and/or performed under this Agreement, and the continuation of said failure for thirty (30) days after the Village's receipt of written notice thereof from the Commission. However, if said failure cannot be remedied by the Village within said thirty (30) day period and the Village has diligently pursued the resolution of the failure during said thirty (30) days, the period will be extended by such additional time as may be reasonably required by the Village to cure or correct said failure. In no event will the period be

extended by more than ninety (90) days. In the event of a default by the Village under this Agreement, the Commission will have the same remedies as are provided for, and only the remedies provided for, in the Water Purchase and Sale Contract for a default by the Village;

2. A default under the October 17, 2024 Intergovernmental Agreement Concerning Development of Connection Facilities to Implement Water Service; or
3. A default under the October 17, 2024 WaterLink Project Escrow Intergovernmental Agreement.

In the event of a default by the Village, the Commission will: (1) be paid its reasonable attorneys' fees and costs incurred in connection with that default, in addition to any attorneys' fees and costs incurred in enforcing the terms of this Agreement; (2) be entitled to the right to enforce a lien against all income derived from the Montgomery Unit System, other than that income necessary to pay any loans to the State of Illinois or its agencies for the construction of the Montgomery Unit System, until the Village's Capital Cost Recovery Amount and any amounts due from the Village under the WaterLink Project Escrow Intergovernmental Agreement are paid back in full; and (3) will have the same remedies as are provided for in the Water Purchase and Sale Contract for a default by the Village.

C. Force Majeure. In case by reason of a force majeure event, either party to this Agreement will be rendered unable wholly or in part to carry out its obligation under this Agreement, then if such party will give notice and full particulars of such force majeure event in writing to the other party within a reasonable time after occurrence of the event or cause relied on, the obligation of the party giving such notice, so far as it is affected by such force majeure event, will be suspended during the continuance of the inability then claimed, but for no longer period,

and any such party will endeavor to remove or overcome such inability with all reasonable dispatch. The term “force majeure event” as employed in this Agreement will mean acts of God, strikes, lockouts, or other industrial disturbances, acts of public enemy, orders of any kind of the Government of the United States, of the State of Illinois, or of any civil or military authority, insurrections, riots, epidemics, pandemics, landslides, lightning, earthquakes, fires, hurricanes, storms, floods, washouts, droughts, arrests, restraints of government and people, civil disturbances, explosions, breakage or accidents to machinery, pipelines, canals, or tunnels, partial or entire failure of water supply, and inability on the part of the Commission or of the Village to deliver Lake Michigan water, or of the Village to receive Lake Michigan water, on account of any other causes not reasonably within the control of the party claiming such inability. The settlement of strikes and lockouts will be entirely within the discretion of the party having the difficulty, and the above requirement that any “force majeure event” will be remedied with all reasonable dispatch will not require the settlement of strikes and lockouts by acceding to the demands of the opposing party or parties when such settlement is unfavorable to it in the judgment of the party having the difficulty.

SECTION 4. LEGAL RELATIONSHIPS AND REQUIREMENTS

A. Supplemental Agreement. This Agreement will be deemed to supplement the Water Purchase and Sale Contract in connection with the supply of Lake Michigan water to the Montgomery Unit System. If there is any other conflict or inconsistency between the terms of this Agreement and the terms of the Water Purchase and Sale Contract, then the terms of this Agreement will control. The Village will at all times comply with all terms and conditions of the Water Purchase and Sale Contract, except as otherwise provided in this Agreement.

B. Term of Agreement. This Agreement will continue in full force and effect from the Effective Date until the Capital Cost Recovery Amount is paid in full by the Village.

C. Cooperation and Further Agreements. The Commission and the Village agree to cooperate in good faith throughout the term of this Agreement to implement the letter and spirit of the provisions set forth in this Agreement.

D. Assignment. This Agreement may not be assigned by any party, in whole or in part, without the prior written consent of the other party.

E. Notices. Any notices under this Agreement will be personally delivered, delivered by the deposit thereof in the U. S. Postal Service, postage prepaid, registered, or certified, return receipt requested, or by overnight courier service to the Party at the address listed below or at another address hereafter designated by notice, or by email transmission. Any such notice will be deemed to have been delivered and given upon personal delivery or delivery by a nationally recognized overnight courier service, or deposit with the United States Postal Service or upon receipt of written confirmation that facsimile or email transmission has been successfully completed:

If to the Commission:

Paul D. May, P.E., General Manager
DuPage Water Commission
600 E. Butterfield Road
Elmhurst, IL 60126
Email: may@dpwc.org

With a copy to:

Phillip A. Luetkehans
Luetkehans, Brady, Garner & Armstrong
2700 International Drive, Suite 305
West Chicago, IL 60185
Email: pal@lbgalaw.com

If to the Village:

Village Administrator
Village of Montgomery
200 N. River Street
Montgomery, IL 60538
Email: zoephel@montgomeryil.org

With a copy to:

Laura M. Julien
Village Attorney
Mickey, Wilson, Weiler, Renzi, Lenert & Julien PC
140 Municipal Drive
Sugar Grove, IL 60554

With a copy to:

Irene Schild Caminer
Caminer Law, LLC
2612 W. Sunnyside Ave.
Chicago, IL 60625
Email: Irene@caminerlaw.com

By notice complying with the requirements of this Section 4.E, the Commission and the Village each will have the right to change the address or addressee or both for all future notices to it, but no notice of a change of address will be effective until actually received.

F. No Oral Agreements. No oral agreements exist by or between the Commission and the Village with respect to this Agreement, nor was the making and execution of this Agreement induced by any representation, statement, warranty, agreement, or action other than those expressed or explicitly referenced in this Agreement.

G. No Waiver. No course of dealing or failure of the Commission or the Village to enforce strictly any term, right, or condition of this Agreement will be construed as a waiver of

such term, right, or condition. No express waiver of any term, right, or condition of this Agreement will operate as a waiver of any other term, right, or condition.

H. No Third-Party Beneficiaries. This Agreement is entered into solely for the benefit of the contracting parties, and nothing in this Agreement is intended, either expressly or impliedly, to provide any right or benefit of any kind whatsoever to any person or entity who is not a party to this Agreement, or to acknowledge, establish, or impose any legal duty to any third party.

I. Governing Law and Venue. This Agreement will be governed by and construed exclusively under the applicable laws, but not the conflict of laws rules, of the State of Illinois. Venue for any litigation arising out of this Agreement will only be proper in the Eighteenth Judicial Circuit Court, DuPage County, Illinois.

J. Counterparts. This Agreement may be executed in several counterparts, each of which will be deemed to be an original, and all of which will constitute but one and the same instrument. Any such counterpart may be signed by one or more of the parties hereto so long as each of the parties hereto has signed one or more of such counterparts.

K. Authority. The person(s) executing this Agreement on behalf of the Parties hereto warrant that: (i) such the Village and the Commission are duly organized and existing; (ii) the individual signing is duly authorized to execute and deliver this Agreement on behalf of said Village or the Commission; (iii) by so executing this Agreement, such Village and the Commission are formally bound to the provisions and conditions contained in this Agreement; and (iv) the entering into this Agreement by the Village and the Commission does not violate any provision of any other agreement to which said Village and the Commission is bound.

L. Cooperation. The Village and the Commission acknowledge that it may be necessary to execute documents other than those specifically referred to herein in order to

complete the objectives and requirements that are set forth in this Agreement. The Village and the Commission hereby agree to cooperate with each other by executing such other documents or taking such other actions as may be reasonably necessary to complete the objectives and requirements set forth herein in accordance with the intent of the Village and the Commission as evidenced by this Agreement.

M. Amendment. This Agreement is the entire agreement between the Village and the Commission regarding its subject matter and may not be changed or amended except pursuant to a written instrument signed by the Village and the Commission.

IN WITNESS WHEREOF, the Village and the Commission hereto have caused their respective corporate names to be subscribed hereto and their respective corporate seals to be affixed hereto and attested by their duly authorized officers.

ATTEST: DuPAGE WATER COMMISSION

By: _____ By: _____

Its: _____ Its: _____

ATTEST: VILLAGE OF MONTGOMERY

By: _____ By: _____

Its: _____ Its: _____



Resolution #: R-66-24

Account: N/A

Approvals: *Author / Manager / Finance / Admin*

PDM - - PDM

REQUEST FOR BOARD ACTION

Date: 10/9/2024

Description: **Recommendation to Approve the WaterLink Connection Facilities IGA**

Agenda Section: Administration Committee

Originating Department: Administration

Construction of significant infrastructure will be necessary to provide Lake Michigan drinking water to the WaterLink communities of Montgomery, Oswego, and Yorkville. Activities associated with Phase I Engineering and Phase II Engineering have been funded by the WaterLink communities through deposits into escrow accounts for that purpose.

Presented for DWC Board consideration today are the Water Purchase and Sale agreements (3), and the Capital Cost Recovery Charge agreements (3) for the WaterLink communities of Montgomery, Oswego, and Yorkville. Upon approval of these six agreements, the WaterLink communities will become customers of the DuPage Water Commission, and DWC will be charged with constructing the pipeline extensions (“WaterLink Connection Facilities”) to convey Lake Michigan water to the WaterLink service area. Phase II Engineering is advancing well, and DWC is preparing for construction to commence in 2025, with completion and commissioning of the new infrastructure in 2028.

The attached “Connection Facilities Intergovernmental Agreement” is the instrument which documents the obligation of the WaterLink communities to provide full funding for all activities associated with the extension of the DWC system to serve the WaterLink service area, including, legal, engineering, property acquisition, construction, and commissioning activities. The IGA also incorporates by reference the external Cost Share Agreement between the communities which establishes the percentage share of cost to be committed by each community to ensure full funding and continuity among funding sources/agreements. This document is accompanied by the companion WaterLink Project Escrow Agreement, which establishes the mechanism for fund deposits (R-67-24).

Recommended Motion:

It is recommended that the DWC Board approve the WaterLink Connection Facilities Intergovernmental Agreement

RESOLUTION NO. R-66-24

A RESOLUTION APPROVING AN INTERGOVERNMENTAL AGREEMENT CONCERNING DEVELOPMENT OF CONNECTION FACILITIES TO IMPLEMENT WATER SERVICE

WHEREAS, the Commission was formed and exists pursuant to the Water Commission Act of 1985, 70 ILCS 3720/0.01 et seq., and Division 135 of Article 11 of the Illinois Municipal Code, 65 ILCS 5/11-135-1 et seq., for the purpose of securing an adequate source and supply of water for its customers; and

WHEREAS, the Village of Montgomery (“Montgomery”), the Village of Oswego (“Oswego”) and the United City of Yorkville (“Yorkville”) (collectively the “Municipalities”) desire to supply Lake Michigan water to their residents by connecting to the Commission’s waterworks system (the “Project”); and

WHEREAS, the Commission and the Municipalities have negotiated an Intergovernmental Agreement Concerning Development of Connection Facilities to Implement Water Service (the “Development Agreement”) for the Project; and

WHEREAS, concurrently with the approval of the Development Agreement, the Commission is entering into a WaterLink Project Escrow Intergovernmental Agreement with the Municipalities for the Project; and

WHEREAS, each Municipality and the Commission are also concurrently entering into an Intergovernmental Agreement Concerning Capital Cost Recovery Charge and a Water Purchase and Sale Contract for the Project; and

WHEREAS, the Commission deems it to be in the best interests of the Commission and the public to complete the Project and enter into the Development Agreement with the Municipalities.

NOW, THEREFORE, BE IT RESOLVED by the Board of Commissioners of the DuPage Water Commission as follows:

SECTION ONE: The Board of Commissioners of the DuPage Water Commission hereby approves the Intergovernmental Agreement Concerning Development of Connection Facilities to Implement Water Service attached hereto as Exhibit 1 and authorizes the Chairman to execute the agreement on behalf of the DuPage Water Commission and to take whatever steps necessary to effectuate the terms of said agreement.

SECTION TWO: This Resolution shall be in full force and effect after passage and approval as required by law.

	Aye	Nay	Absent	Abstain
Bouckaert, D.				
Cuzzone, N.				
Fennell, J.				
VACANT	_____			
Novotny, D.				
Pruyn, J.				
Romano, K.				
Rush, K.				
Russo, D.				
Saverino, F.				
Suess, P.				
Van Vooren, D.				
Zay, J.				

ADOPTED THIS _____ DAY OF _____, 2024.

James F. Zay, Chairman

ATTEST:

Danna Mundall, Clerk

Board/Resolutions/2024/R-66-24.docx

EXHIBIT 1

**INTERGOVERNMENTAL AGREEMENT CONCERNING DEVELOPMENT OF
CONNECTION FACILITIES TO IMPLEMENT WATER SERVICE**

This Intergovernmental Agreement, (the “Agreement”) is dated the 17th day of October, 2024 (the “Effective Date”), by and between the Village of Montgomery (“Montgomery”), the Village of Oswego (“Oswego”), and the United City of Yorkville (“Yorkville”) (Oswego, Montgomery, and Yorkville are collectively referred to herein as the “WaterLink Communities”) and the DuPage Water Commission, (the “Commission”) a county water commission and public corporation under Division 135 of Article 11 of the Illinois Municipal Code, 65 ILCS 5/11-135-1 *et seq.*, and the Water Commission Act of 1985, 70 ILCS 3720/0.01 *et seq.* (the “Acts”).

WITNESSETH:

WHEREAS, the Commission has been organized under the Acts to supply water within its territorial limits; and

WHEREAS, the WaterLink Communities currently own and operate municipal drinking water systems served by wells that extract source water from the Ironton-Galesville aquifer; and

WHEREAS, the WaterLink Communities are within the territorial limits of the Commission; and

WHEREAS, the WaterLink Communities intend to change from the Ironton-Galesville groundwater source to Lake Michigan source water, through a water purchase agreement with the Commission, and have applied for and been awarded a Lake Michigan Water Allocation Permit (“Permit”) from the State of Illinois Department of Natural Resources, Office of Water Resources for each discrete and non-contiguous service area served by each WaterLink Community’s Unit System; and

WHEREAS, the WaterLink Communities have conducted extensive study and concluded that the most sustainable alternative water source to serve the WaterLink Communities through the municipal waterworks systems currently serving the WaterLink Communities, as well as any extensions or improvements of those systems is Lake Michigan water from the Commission; and

WHEREAS, the Commission owns and maintains a waterworks system as a supplier of Lake Michigan water to member customers that contract for such service (“Commission’s Waterworks System”); and

WHEREAS, the WaterLink Communities seek to connect to their individual Unit Systems to Lake Michigan through the Commission; and

WHEREAS, beginning in 2028 the WaterLink Communities seek to have completed the improvements to certain of their WaterLink Communities’ individual Unit Systems necessary to connect to the Commission’s Waterworks System (the “Connection Facilities”); and

WHEREAS, the Commission has entered into a water supply contract with the City of Chicago to purchase Lake Michigan water sufficient to meet the water supply needs of the Commission and its customers (“Water Supply Contract”); and

WHEREAS, the Commission’s Water Supply Contract with the City of Chicago is set to expire in 2041 and the Commission is currently: (1) exploring an alternative solution to obtaining Lake Michigan water; and (2) in discussions and negotiations with the City of Chicago for a new Water Supply Contract; and

WHEREAS, the construction of certain improvements to the Commission's Waterworks System will enable the WaterLink Communities to provide water to the Individual Unit Systems (the "Improvements"); and

WHEREAS, to carry out their duties and responsibilities, and desiring to create a method of providing an adequate supply of Lake Michigan water to the Individual Unit Systems, the Commission and the WaterLink Communities, contemporaneously with this Agreement, are entering into a Water Purchase and Sale Contract dated October 17, 2024 (the "Water Purchase Agreement"); and

WHEREAS, it is in the best interests of the Commission and the WaterLink Communities to coordinate and implement the supply of Lake Michigan water to the Individual Unit Systems in accordance with the Water Purchase Agreement; and

WHEREAS, the Commission and the WaterLink Communities desire to set forth their understanding regarding such coordination and implementation in this Agreement; and

WHEREAS, the matters set forth in this Agreement will serve the public interest and assure that the residents of the Individual Unit Systems are provided safe water to the greatest extent possible; and

WHEREAS, pursuant to Section 10 of Article VII of the Illinois Constitution of 1970, the provisions of the Intergovernmental Cooperation Act, 5 ILCS 220/1 *et seq.*, and other applicable authority, the Commission and the WaterLink Communities are authorized to enter into this Agreement; and

WHEREAS, contemporaneously with this Agreement, the WaterLink Communities and the Commission are entering into other agreements including but not limited to a WaterLink

Project Escrow Intergovernmental Agreement to fund the construction of the Connection Facilities (the “WaterLink Escrow Agreement”); and

WHEREAS, the WaterLink Communities have previously agreed to each Municipality’s percentage share of the Connection Facilities Cost pursuant to an Intergovernmental Cost Share Agreement (the “Cost Share Agreement”). The WaterLink Communities agree that the costs paid for the Connection Facilities will mirror the Division of Financial Responsibilities/Allocation of Costs set forth in the Cost Share Agreement. Specifically, Montgomery commits and agrees to pay 24.42%, Yorkville commits and agrees to pay 40.22% and Oswego commits and agrees to pay 35.36%. The Commission is not a party to the Cost Share Agreement and has no responsibility or liability as to any true-up or adjusted accounting between the WaterLink Communities.

NOW, THEREFORE, in consideration of the foregoing and the mutual covenants and agreements hereinafter set forth, the Commission and the WaterLink Communities hereby agree as follows:

SECTION 1. INCORPORATION OF PREAMBLES AND DEFINITIONS FROM WATER PURCHASE AGREEMENT

The foregoing recitals are by this reference incorporated herein and made a part hereof as if fully set forth herein. Further, to the extent any capitalized terms in this Agreement are set forth as a defined term in the Water Purchase Agreement, the capitalized terms in this Agreement will have the same meaning in this Agreement as the definition in the Water Purchase Agreement.

SECTION 2. CONSTRUCTION OF IMPROVEMENTS; EXTENSION OF SERVICE

A. Description of the Connection Facilities. For purposes of this Agreement, the Connection Facilities will include the water mains, metering station(s), and appurtenances necessary to be built by the Commission to provide water to the WaterLink Communities,

including portions of the Waterworks System constructed by the Commission to initially connect the WaterLink Communities' individual Unit Systems to the Commission's existing Waterworks System as depicted in preliminary plans attached to the Water Purchase Agreement as Exhibits B-1 and B-2.

B. Design of the Connection Facilities. As outlined in the Water Purchase Agreement, the Commission will be the contracting party with the design engineer and will administer the design contract for the benefit of both the Commission and the WaterLink Communities for the Connection Facilities. The Commission will keep the WaterLink Communities advised as to the progress of the design work. The Commission and the WaterLink Communities will confer upon issues regarding the details of such design work. The final design of the Connection Facilities will be subject to the review of both the Commission and the WaterLink Communities.

C. Land Acquisition. The Commission will be responsible for the acquisition and divestment of lands, easements, and rights of way over lands and waters necessary for the construction, installation, removal, relocation, replacement, extension, and/or improvement of the Connection Facilities outside the corporate limits of the WaterLink Communities and all administrative, title, surveying, and legal fees, costs and expenses associated therewith, including, if necessary, exercising the power of eminent domain to procure any necessary easements, which expenses will be added to the Connection Facilities Cost amount that the WaterLink Communities will pay the Commission. The Commission will keep the WaterLink Communities advised of all land acquisition costs and any necessary condemnation proceedings. All land acquired and costs associated therewith within the WaterLink Communities will be the sole responsibility of the WaterLink Communities.

D. Construction and Acceptance of the Connection Facilities. The Commission will solicit bids for the construction of the Connection Facilities. The Commission's standard form of bidding and construction contract documents will be used. The Commission will solicit, award, and administer all contracts for the project in the best interest of both the Commission and the WaterLink Communities and will consult with, and keep advised, the WaterLink Communities' officials regarding the progress of the work and any problems encountered or changes recommended. Once the winning contractor(s) and the construction costs have been determined, the Commission will enter into a construction contract(s) with the selected contractor(s) and will administer such construction contract(s) in conformance with this Agreement. Any change orders, as well as final acceptance and approval of the completed Connection Facilities, will be subject to the final approval of the Commission.

E. Connection Facilities Cost. In accordance with the WaterLink Project Escrow Intergovernmental Agreement, the Commission, will make available in the form of a Line of Credit to the WaterLink Communities funds needed for the Connection Facilities Cost, up to the amount of the Commitment Amount as that term is defined therein, and the WaterLink Communities agree to reimburse the Commission for those costs.

SECTION 3. DEFAULTS AND REMEDIES

A. Commission Defaults. The occurrence of the following will constitute a default by the Commission under this Agreement: The failure by the Commission to observe and/or perform any covenant, condition, and/or agreement on its part to be observed and/or performed under this Agreement, and the continuation of said failure for thirty (30) days after the Commission's receipt of written notice thereof from the WaterLink Communities. However, if said failure cannot be remedied by the Commission within said thirty (30) day period, and the Commission has diligently

pursued the resolution of the failure during said thirty (30) days, the period will be extended by such additional time as may be reasonably required by the Commission to cure or correct said failure. In no event will the period be extended by more than ninety (90) days. In the event of a default by the Commission under this Agreement, the WaterLink Communities will have the same remedies as are provided for, and only the remedies provided for, in the Water Purchase Agreement for a default by the Commission.

B. WaterLink Communities Defaults. The occurrence of the following will constitute a default by the WaterLink Communities under this Agreement:

1. The failure by the WaterLink Communities to observe and/or perform any covenant, condition, and/or agreement on its part to be observed and/or performed under this Agreement, and the continuation of said failure for thirty (30) days after the WaterLink Communities' receipt of written notice thereof from the Commission. However, if said failure cannot be remedied by the WaterLink Communities within said thirty (30) day period, and the WaterLink Communities will have diligently pursued the resolution of the failure during said thirty (30) days, the period will be extended by such additional time as may be reasonably required by the WaterLink Communities to cure or correct said failure. In no event will the period be extended by more than ninety (90) days; or
2. A default by the WaterLink Communities under the WaterLink Project Escrow Intergovernmental Agreement; or
3. A default by any of the WaterLink Communities under the Intergovernmental Agreements with each individual WaterLink Community Concerning Capital Cost Recovery Charge.

In the event of one of the above defaults, the Commission will: (i) be paid its reasonable attorneys' fees and costs incurred in connection with that default, in addition to any attorneys' fees and costs incurred in enforcing the terms of this Agreement; (2) be entitled to the right to enforce a lien against all income derived from the WaterLink Communities individual Unit Systems, other than that income necessary to pay any loans to the Government of the United States, of the State of Illinois or their agencies for the construction of the WaterLink Communities individual Unit Systems, until the line of credit referenced in the WaterLink Project Escrow Intergovernmental Agreement is paid back in full; and (3) will have the same remedies as are provided for in the Water Purchase Agreements for a default by the individual WaterLink Communities.

C. Force Majeure. In case by reason of a force majeure event, a party to this Agreement will be rendered unable wholly or in part to carry out its obligation under this Agreement, then if such party will give notice and full particulars of such force majeure event in writing to the other party within a reasonable time after occurrence of the event or cause relied on, the obligation of the party giving such notice, so far as it is affected by such force majeure event, will be suspended during the continuance of the inability then claimed, but for no longer period, and any such party will endeavor to remove or overcome such inability with all reasonable dispatch. The term "force majeure event" as employed in this Agreement will mean acts of God, strikes, lockouts, or other industrial disturbances, acts of public enemy, orders of any kind of the Government of the United States, of the State of Illinois, or of any civil or military authority, insurrections, riots, epidemics, pandemics, landslides, lightning, earthquakes, fires, hurricanes, storms, floods, washouts, droughts, arrests, restraints of government and people, civil disturbances, explosions, breakage or accidents to machinery, pipelines, canals, or tunnels, partial or entire failure of water supply, and inability on the part of the Commission or of the WaterLink

Communities to deliver Lake Michigan water, or of the WaterLink Communities to receive Lake Michigan water, on account of any other causes not reasonably within the control of the party claiming such inability. The settlement of strikes and lockouts will be entirely within the discretion of the party having the difficulty and the above requirement that any “force majeure event” will be remedied with all reasonable dispatch will not require the settlement of strikes and lockouts by acceding to the demands of the opposing party or parties when such settlement is unfavorable to it in the judgment of the party having the difficulty.

SECTION 4. LEGAL RELATIONSHIPS AND REQUIREMENTS

A. Supplemental Agreement. This Agreement will be deemed to supplement the Water Purchase Agreement in connection with the supply of Lake Michigan water to the WaterLink Communities. If there is any other conflict or inconsistency between the terms of this Agreement and the terms of the Water Purchase Agreement, then the terms of this Agreement will control. The WaterLink Communities will at all times comply with all terms and conditions of the Water Purchase Agreement except as otherwise provided in this Agreement.

B. Term of Agreement. This Agreement will continue in full force and effect from the Effective Date until the Line of Credit is paid in full by the WaterLink Communities.

C. Cooperation and Further Agreements. The Commission and WaterLink Communities agree to meet and cooperate in good faith throughout the term of this Agreement to implement the letter and spirit of the provisions set forth in this Agreement.

D. Assignment. This Agreement may not be assigned by any party, in whole or in part, without the prior written consent of the other party.

E. Notices. Any notices under this Agreement will be personally delivered, delivered by the deposit thereof in the U. S. Postal Service, postage prepaid, registered, or

certified, return receipt requested, or by overnight courier service to the Party at the address listed below or at another address hereafter designated by notice or by email transmission. Any such notice will be deemed to have been delivered and given upon personal delivery or delivery by a nationally recognized overnight courier service, or deposit with the United States Postal Service or upon receipt of written confirmation that facsimile or email transmission has been successfully completed:

If to the Commission:

Paul D. May, P.E., General Manager
DuPage Water Commission
600 E. Butterfield Road
Elmhurst, IL 60126
Email: may@dpwc.org

With a copy to:

Phillip A. Luetkehans
Luetkehans, Brady, Garner & Armstrong
2700 International Drive, Suite 305
West Chicago, IL 60185
Email: pal@lbgalaw.com

If to the WaterLink Communities:

Village Administrator
Village of Oswego
100 Parkers Mill
Oswego, IL 60543
Email: info@oswegoil.org

With a copy to:

David J. Silverman
Village Attorney
Mahoney, Silverman, & Cross, LLC
126 South Main Street
Oswego, Illinois 60543

Village Administrator
Village of Montgomery
200 N River Street
Montgomery, IL 60538
Email: zoephel@montgomeyil.org
With a copy to:

Laura M. Julien
Village Attorney
Mickey Wilson, Weiler, Renzi, Lenert, & Julien, PC
140 Municipal Drive
Sugar Grove, IL 60554

City Administrator
United City of Yorkville
800 Game Farm Road
Yorkville, IL 60560
Email: bolson@yorkville.il.us

With a copy to:

Kathleen Field Orr & Associates
Kathleen Field Orr
2024 Hickory Road, Suite 205
Homewood, IL 60430

With a copy to:

Irene Schild Caminer
Caminer Law, LLC
2612 W. Sunnyside Ave.
Chicago, IL 60625
Email: Irene@caminerlaw.com

By notice complying with the requirements of this Section 4.E, the Commission and the WaterLink Communities each will have the right to change the address or addressee or both for all future notices to it, but no notice of a change of address will be effective until actually received.

F. No Oral Agreements. No oral agreements exist by or between the Commission and the WaterLink Communities with respect to this Agreement, nor was the making and execution of this Agreement induced by any representation, statement, warranty, agreement, or action other than those expressed or explicitly referenced in this Agreement.

G. No Waiver. No course of dealing or failure of the Commission or the WaterLink Communities to enforce strictly any term, right, or condition of this Agreement will be construed as a waiver of such term, right, or condition. No express waiver of any term, right, or condition of this Agreement will operate as a waiver of any other term, right, or condition.

H. No Third-Party Beneficiaries. This Agreement is entered into solely for the benefit of the contracting parties, and nothing in this Agreement is intended, either expressly or impliedly, to provide any right or benefit of any kind whatsoever to any person or entity who is not a party to this Agreement, or to acknowledge, establish, or impose any legal duty to any third party.

I. Governing Law and Venue. This Agreement will be governed by and construed exclusively under the applicable laws, but not the conflict of laws rules, of the State of Illinois. Venue for any litigation arising out of this Agreement will only be proper in the Eighteenth Judicial Circuit Court, DuPage County, Illinois.

J. Counterparts. This Agreement may be executed in several counterparts, each of which will be deemed to be an original, and all of which will constitute but one and the same instrument. Any such counterpart may be signed by one or more of the parties hereto so long as each of the parties hereto has signed one or more of such counterparts.

K. Authority. The person(s) executing this Agreement on behalf of the Parties hereto warrant that: (i) such The WaterLink Communities and the Commission are duly organized and existing; (ii) the individual signing is duly authorized to execute and deliver this Agreement on

behalf of said WaterLink Communities or the Commission; (iii) by so executing this Agreement, such WaterLink Communities and the Commission are formally bound to the provisions and conditions contained in this Agreement; and (iv) the entering into this Agreement by the WaterLink Communities and the Commission does not violate any provision of any other agreement to which said WaterLink Communities and the Commission is bound.

L. Mutual Cooperation. The WaterLink Communities and the Commission acknowledge that it may be necessary to execute documents other than those specifically referred to herein in order to complete the objectives and requirements that are set forth in this Agreement. the WaterLink Communities and the Commission hereby agree to cooperate with each other by executing such other documents or taking such other actions as may be reasonably necessary to complete the objectives and requirements set forth herein in accordance with the intent of the WaterLink Communities and the Commission as evidenced by this Agreement.

M. Amendment. This Agreement is the entire agreement between the WaterLink Communities and the Commission regarding its subject matter and may not be changed or amended except pursuant to a written instrument signed by each Municipality and the Commission.

IN WITNESS WHEREOF, The WaterLink Communities and the Commission hereto have caused their respective corporate names to be subscribed hereto and their respective corporate seals to be affixed hereto and attested by their duly authorized officers, all on the date set opposite their respective corporate names.

ATTEST:

DuPage Water Commission

BY: _____

ATTEST:

Village of Montgomery

BY: _____

ATTEST:

Tina Touchette

Village of Oswego

BY: [Signature]

ATTEST:

Joni Behlman by Monica Cisyak
Deputy Clerk

United City of Yorkville

BY: [Signature]



Resolution #: R-67-24

Account: N/A

Approvals: *Author / Manager / Finance / Admin*

PDM - - PDM

REQUEST FOR BOARD ACTION

Date: 10/9/2024

Description: **Recommendation to Approve the WaterLink Project Escrow Agreement**

Agenda Section: Administration Committee

Originating Department: Administration

Presented for DWC Board consideration today are the Water Purchase and Sale agreements (3), and the Capital Cost Recovery Charge agreements (3) for the WaterLink communities of Montgomery, Oswego, and Yorkville. Upon approval of these six agreements, the WaterLink communities will become customers of the DuPage Water Commission, and DWC will be charged with constructing the pipeline extensions (“WaterLink Connection Facilities”) to convey Lake Michigan water to the WaterLink service area. The companion “Connection Facilities Intergovernmental Agreement” (R-67-24) has also been presented for consideration, and upon approval will obligate the WaterLink communities to provide full funding for all activities associated with the extension of the DWC system to serve the WaterLink service area.

The “WaterLink Project Escrow Agreement” attached hereto is the instrument which establishes the mechanism for fund deposits for the construction of the DWC infrastructure extensions (“WaterLink Connection Facilities”). This document has been crafted to maintain continuity of approach with the previously approved Escrow Agreements which have been successfully utilized for Phase I and Phase II Engineering work. Items of note include a requirement for a standing \$30M balance, as well as an optional DWC line-of-credit in an amount not-to-exceed \$21M, providing parity with the terms offered for the most recent Bartlett extension.

The intention of the attached agreement is to ensure that adequate deposits are retained in the DWC-controlled escrow account to cover the cost of all construction activities for which payment is expected to be obligated on a quarterly basis over the 3-year construction/commissioning schedule.

Recommended Motion:

It is recommended that the DWC Board approve the WaterLink Project Escrow Agreement

DUPAGE WATER COMMISSION

RESOLUTION NO. R-67-24

A RESOLUTION APPROVING WATERLINK PROJECT ESCROW INTERGOVERNMENTAL AGREEMENT

WHEREAS, the Commission was formed and exists pursuant to the Water Commission Act of 1985, 70 ILCS 3720/0.01 et seq., and Division 135 of Article 11 of the Illinois Municipal Code, 65 ILCS 5/11-135-1 et seq., for the purpose of securing an adequate source and supply of water for its customers; and

WHEREAS, the Village of Montgomery (“Montgomery”), the Village of Oswego (“Oswego”) and the United City of Yorkville (“Yorkville”) (collectively the “Municipalities”) desire to supply Lake Michigan water to their residents by connecting to the Commission’s waterworks system (the “Project”); and

WHEREAS, the Commission and the Municipalities have negotiated a WaterLink Project Escrow Intergovernmental Agreement (the “Escrow Agreement”) for the Project; and

WHEREAS, concurrently with the approval of the Escrow Agreement, the Commission is entering into an Intergovernmental Agreement Concerning Development of Connection Facilities to Implement Water Service with the Municipalities for the Project; and

WHEREAS, each Municipality and the Commission are also concurrently entering into an Intergovernmental Agreement Concerning Capital Cost Recovery Charge and a Water Purchase and Sale Contract for the Project; and

WHEREAS, the Commission deems it to be in the best interests of the Commission and the public to complete the Project and enter into the Escrow Agreement with the Municipalities.

NOW, THEREFORE, BE IT RESOLVED by the Board of Commissioners of the DuPage Water Commission as follows:

SECTION ONE: The Board of Commissioners of the DuPage Water Commission hereby approves the WaterLink Project Escrow Intergovernmental Agreement attached hereto as Exhibit 1 and authorizes

the Chairman to execute the agreement on behalf of the DuPage Water Commission and to take whatever steps necessary to effectuate the terms of said agreement.

SECTION TWO: This Resolution shall be in full force and effect after passage and approval as required by law.

	Aye	Nay	Absent	Abstain
Bouckaert, D.				
Cuzzone, N.				
Fennell, J.				
VACANT	_____			
Novotny, D.				
Pruyn, J.				
Romano, K.				
Rush, K.				
Russo, D.				
Saverino, F.				
Suess, P.				
Van Vooren, D.				
Zay, J.				

ADOPTED THIS _____ DAY OF _____, 2024.

ATTEST:

James F. Zay, Chairman

Danna Mundall, Clerk

Board/Resolutions/2024/R-67-24.docx

EXHIBIT 1

**WATERLINK PROJECT
ESCROW INTERGOVERNMENTAL AGREEMENT**

This WaterLink Project Escrow Intergovernmental Agreement (the “WaterLink Project Escrow Agreement” or this “Agreement”) is dated the 17th day of October 2024 between the Village of Montgomery (“Montgomery”), the Village of Oswego (“Oswego”), and the United City of Yorkville (“Yorkville”) (Oswego, Montgomery, and Yorkville are collectively referred to herein as the “WaterLink Communities”) and the DuPage Water Commission (the “Commission”), a county water commission and public corporation under Division 135 of Article 11 of the Illinois Municipal Code, 65 ILCS 5/11-135-1 *et seq.*, and the Water Commission Act of 1985, 70 ILCS 3720/0.01 *et seq.* (the “Acts”).

WITNESSETH:

WHEREAS, the Commission has been organized under the Acts to supply water within its territorial limits; and

WHEREAS, the WaterLink Communities currently own and operate municipal drinking water systems served by wells that extract source water from the Ironton-Galesville aquifer; and

WHEREAS, the WaterLink Communities are within the territorial limits of the Commission; and

WHEREAS, the WaterLink Communities intend to change from the Ironton-Galesville groundwater source to Lake Michigan source water, through water purchase and sale agreements with the Commission, and have applied for and been awarded Lake Michigan Water Allocation Permits from the State of Illinois Department of Natural Resources, Office of Water Resources for each discrete and non-contiguous service area served by each WaterLink Community’s Unit System (“Service Area”); and

WHEREAS, the WaterLink Communities have conducted extensive study and have concluded that the most sustainable alternative water source to serve the WaterLink Communities through the municipal waterworks systems currently serving the WaterLink Communities, as well as any extensions or improvements of those systems, is Lake Michigan water from the Commission; and

WHEREAS, the Commission owns and maintains a waterworks system as a supplier of Lake Michigan water to member customers that contract for such service (“Commission’s Waterworks System”); and

WHEREAS, the parties seek to complete the improvements necessary to connect the Commission’s Waterworks System to the WaterLink Communities’ individual Unit Systems in 2028; and

WHEREAS, the Commission has entered into a Water Supply Contract with the City of Chicago to purchase Lake Michigan water sufficient to meet the water supply needs of the Commission and its customers; and

WHEREAS, the Commission’s Water Supply Contract with the City of Chicago is set to expire in 2041, and the Commission is currently: (1) exploring an alternative solution to obtaining Lake Michigan water; and (2) in discussions and negotiations with the City of Chicago for a new Water Supply Contract; and

WHEREAS, to carry out their duties and responsibilities, and desire to create a method of providing an adequate supply of Lake Michigan water to the Service Area, the Commission and each of the WaterLink Communities, contemporaneously with this Agreement are entering into Water Purchase and Sale Contracts (the “Water Purchase Agreements”) and this Agreement incorporates the defined terms of the Water Purchase Agreements unless otherwise specified herein; and

WHEREAS, to become a member of the Commission and comply with the Water Purchase Agreements, each WaterLink Community must pay its proportional share of the costs for the property owned by the Commission; and

WHEREAS, contemporaneously with this Agreement, the WaterLink Communities and the Commission are each entering into a Capital Cost Recovery Agreements that establish the terms and conditions for financing each WaterLink Community’s proportional share of the costs for the property owned by the Commission; and

WHEREAS, contemporaneously with this Agreement, each WaterLink Community and the Commission are entering into an Intergovernmental Agreement Concerning the Development of Connection Facilities to Implement Water Service (the “Development Agreement”); and

WHEREAS, the WaterLink Communities intend that certain provisions within this Agreement be used only to the extent that one or all of the WaterLink Communities have failed to properly fund this Agreement after notice has been provided in accordance with this Agreement; and

WHEREAS, the Commission will incur in connection with (i) the design, bidding, contracting, managing, and actual construction, installation, removal, relocation, replacement, extension, or improvement of the Connection Facilities, including without limitation equipment required for the operation of the Connection Facilities and all administrative, financing, supervisory, inspection, engineering, surveying, and legal fees, costs, and expenses associated therewith; (ii) the acquisition and divestment of lands, easements, and rights of way over lands and waters necessary for the construction, installation, removal, relocation, replacement, extension, or improvement of the Connection Facilities, and all administrative, title, surveying, and legal fees, costs, and expenses associated therewith; and (iii) the review and processing of plans and agreements for the construction, installation, removal, relocation, replacement, extension, or improvement of the Connection Facilities and in connection with the negotiation, preparation, consideration, and review of this Contract, including without limitation all legal, engineering, consulting, and administrative fees, costs, and expenses associated therewith; except as any of the above are included in Operation and Maintenance Costs (“Connection Facilities Cost”); and

WHEREAS, the Commission and the WaterLink Communities have previously entered into First and Second Escrow Intergovernmental Agreements (the “Prior Escrow Agreements”) for what is defined under those Prior Escrow Agreements as Phase I and Phase 2 Services; and

WHEREAS, prior to the execution of documents requiring the expenditure of Commission Expenses, the Commission requires the WaterLink Communities to establish an additional escrow fund with the Commission as stated herein to provide a funding source for the Commission Expenses beyond those incurred for the Phase 1 and Phase 2 Services; and

WHEREAS, pursuant to the Development Agreement, the WaterLink Communities will be responsible for the Connection Facilities Cost; and

WHEREAS, the WaterLink Communities have previously agreed to each Municipality's percentage share of the Connection Facilities Cost pursuant to an Intergovernmental Cost Share Agreement (the "Cost Share Agreement"). The WaterLink Communities agree that the costs paid into the escrow account under this WaterLink Project Escrow Agreement will mirror the Division of Financial Responsibilities/Allocation of Costs set forth in the Cost Share Agreement. Specifically, Montgomery commits and agrees to pay 24.42%, Yorkville commits and agrees to pay 40.22%, and Oswego commits and agrees to pay 35.36%. The Commission is not a party to the Cost Share Agreement and has no responsibility or liability as to any true-up or adjusted accounting between the WaterLink Communities; and

WHEREAS, pursuant to Article VII, Section 10 of the Illinois Constitution of 1970, and the Intergovernmental Cooperation Act, 5 ILCS 220/1 et seq., the Commission and the WaterLink Communities are authorized to enter into this WaterLink Project Escrow Agreement.

NOW, THEREFORE, in consideration of the foregoing recitals and of the mutual covenants and agreements herein contained, the WaterLink Communities and the Commission hereby agree as follows:

1. The foregoing recitals are by this reference incorporated herein and made a part hereof as if fully set forth herein. Further, to the extent any capitalized terms in this Agreement are set forth as a defined term in the Water Purchase Agreements, the capitalized terms in this Agreement shall have the same meaning in this Agreement as the definition in the Water Purchase Agreements.

2. The Commission will establish a segregated escrow account for the sole purpose of funding the Connection Facilities Cost (the "Waterlink Project Escrow Account"). The WaterLink Communities will each deposit into the Waterlink Project Escrow Account all payments necessary to fund the Connection Facilities Cost. Any remaining funds from the prior Escrow Agreements will remain in the related escrow account, and any funds not expended or necessary for Phase I and Phase II Services, when those phases are complete, may be transferred

to the WaterLink Project Escrow Account, unless otherwise directed by the WaterLink Communities.

3. The Commission will draw from the WaterLink Project Escrow Account to pay for or reimburse any Connection Facilities Cost incurred.

4. The WaterLink Project Escrow Account will be insured and interest-bearing, and the Commission will provide the WaterLink Communities with Quarterly Statements within twenty-one (21) days after the end of each quarter: (1) showing the starting and ending balances for that quarter in the WaterLink Project Escrow Account; and (2) detailing the costs of Connection Facilities Cost incurred for that quarter including any amounts received or paid from the WaterLink Project Escrow Account. The WaterLink Communities will have the right to conduct audits for three years after the termination of this WaterLink Project Escrow Agreement relative to the WaterLink Project Escrow Account.

5. The Commission will keep a record of all pay requests from the WaterLink Project Escrow Account for reimbursement of Connection Facilities Cost incurred (the "Pay Request") and sufficient documentation of the Connection Facilities Cost incurred in support of the Pay Request. The documentation will be retained for review by the WaterLink Communities upon request and included within the Quarterly Statements issued by the Commission.

If at any time during the term of this WaterLink Project Escrow Agreement, the balance in the WaterLink Project Escrow Account is less than Thirty Million Dollars (\$30,000,000.00) (the "Minimum Balance Amount"), the Commission will notify the WaterLink Communities. Within thirty (30) days of the Commission notifying the WaterLink Communities under this Paragraph 5, the WaterLink Communities will each pay the Commission its proportionate share (as set forth in the Cost Share Agreement) of the request to ensure that the Minimum Balance is met. Failure to make such payment when required under this Paragraph 5 shall be considered a default of this Agreement by the WaterLink Communities.

6. The Commission will, after the execution and delivery of this Agreement, make available as a line of credit to the WaterLink Communities an amount not to exceed \$21,000,000

(the “Commitment Amount”) to pay a portion of the Connection Facilities Cost as defined in the Water Purchase Agreements. The actual amounts of money borrowed by each of the WaterLink Communities pursuant to the Commitment Amount will constitute the “Line of Credit.”

7. The WaterLink Communities will repay the principal balance of the Line of Credit, plus accrued and unpaid interest at the Interest Rate set forth in Paragraph 8 of this Agreement from the Interest Commencement Date through the Line of Credit Payment Commencement Date (the “Capitalized Interest”), as those terms are hereinafter defined on the unpaid principal balance, and any Capitalized Interest, of the Line of Credit from and after the Line of Credit Payment Commencement Date, as that term is hereinafter defined, in 240 monthly installments, commencing on the 10th day of every month (the “Monthly Payment Date”) commencing on the Line of Credit Payment Commencement Date as hereafter defined in Paragraph 9 and continuing in successive monthly installments on each Monthly Payment Date in each month thereafter, with the final payment of any unpaid interest and principal, if not sooner paid, on the 240th Monthly Payment Date. Each of the 240 monthly installments of principal on the Line of Credit will be determined as of the last day of the month preceding the Monthly Payment Date in any given year during the term of the Line of Credit (a “Principal Determination Date”) and will be determined by dividing the unpaid principal balance, and any Capitalized Interest, of the Line of Credit as of the applicable Principal Determination Date by the number of monthly installments of principal remaining to be paid during the term of the Line of Credit. The accrued and unpaid interest will be capitalized on a monthly basis until the Line of Credit Payment Commencement Date. There will be no penalty for prepayment.

8. Interest on the unpaid principal balance, and any Capitalized Interest, of the Line of Credit will accrue at a rate (the “Interest Rate”) that is equivalent to the highest yield to maturity interest rate earned by the Commission (based on all investments) as reported monthly on the Commission’s Schedule of Investments for the immediately preceding fiscal year (May 1 – April 30) as determined by the Commission (the “Earned Interest Rate”) plus one percent (1%). Interest will only accrue on money actually borrowed under Paragraph 6 of this Agreement and will begin to accrue when the Commission makes its first draw on the Line of Credit for the WaterLink Communities (the “Interest Commencement Date”). The Interest Rate for each year that the Line

of Credit remains outstanding will be calculated on the basis of a calendar year consisting of 360 days of twelve 30-day months and will be adjusted on May 1st of each year, and will be applied to the outstanding unpaid principal balance, and any Capitalized Interest, as determined on the most recent Principal Determination Date, will be paid commencing on the Monthly Payment Date, and continuing on the Monthly Payment Date each month thereafter until the principal balance of the Line of Credit and all interest thereon has been paid in full.

9. Payments of principal and interest, including Capitalized Interest, will begin no later than the 10th day of the first month after the first delivery of potable, filtered water drawn from Lake Michigan to any of the WaterLink Communities individual Unit Systems as that term is defined in the Water Purchase Agreement (the “Line of Credit Payment Commencement Date”).

10. Payments of the principal and interest will be made in lawful money of the United States of America in federal or other immediately available funds.

11. If at any time, the Commission receives invoices incurred arising out of the Connection Facilities Cost for which there are insufficient funds in the Construction Escrow Agreement, the Commission will pay the actual costs incurred from the Connection Facilities Cost Line of Credit. The Commission payments for the Connection Facilities Cost will be paid out of the Commitment Amount and will be immediately considered part of the Line of Credit. The Commission may make payments from the Line of Credit no more than once per month, on the 10th day of the month, provided that the Commission will give the WaterLink Communities notice (which notice must be received by the WaterLink Communities prior to 10:00 a.m., local time, 7 days prior to the requested borrowing date), specifying the amount to be paid and the payment date. It is anticipated that only a single borrowing will be requested each month. Each borrowing pursuant to this Agreement will be in an aggregate principal amount less than the Available Commitment. For purposes of this Paragraph 11, the Available Commitment at a particular time is an amount equal to the difference between the Commitment Amount and the aggregate principal balance of the Line of Credit then outstanding.

12. Subject to the limitations of Paragraph 12, the WaterLink Communities may, without premium or penalty, upon at least one business day’s irrevocable notice to the

Commission, specifying the date and amount of prepayment, make such prepayment; and the payment amount specified in such notice will be due and payable on the date specified therein. The proceeds of any such prepayment will be applied by the Commission first, to the payment of accrued and unpaid interest, if any, on the Line of Credit, and second, to the payment of the unpaid principal balance of the Line of Credit. The WaterLink Communities will not be entitled to, nor receive any credit for, interest on any such prepayment.

13. The proceeds of the Line of Credit will be devoted to and used with due diligence for the purpose of paying the Connection Facilities Cost identified in Exhibit A; provided, however, that where an unexpended balance remains in any one or more of the various cost components of the Connection Facilities Cost detailed in Exhibit A attached hereto, such balance may be transferred and expended, in whole or in part, to and for any other cost component of the Connection Facilities Cost detailed in Exhibit A attached hereto.

14. The Covenants set forth in Subsections 9A, 9B, 9C, and 9D of the Water Purchase Agreements are incorporated into this Agreement by reference.

15. This WaterLink Project Escrow Agreement will terminate, and any monies not paid or incurred for Connection Facilities Cost, including any interest therein will be returned to the WaterLink Communities, unless mutually agreed to by the WaterLink Communities and the Commission, upon the earlier of:

- a. upon written request by the WaterLink Communities, a written direction that is issued by the General Manager of the Commission that the funds are no longer needed for any Connection Facilities Cost, which direction shall not be unreasonably withheld; or
- b. upon the WaterLink Communities' written notification to the Commission that they are no longer pursuing the purchase of Lake Michigan water from the Commission, and the payment of all the Connection Facilities Cost.

No monies will be returned to the WaterLink Communities until a full accounting has been completed of the expenditures incurred under this WaterLink Project Escrow Agreement.

16. If any WaterLink Community or the Commission defaults in the full and timely performance of any of its obligations hereunder, the non-breaching entity or entities, after first providing written notice to the breaching entity of the event of default and providing the breaching entity ten (10) days to cure the same, will be entitled to invoke its legal rights and remedies as a result thereof, including, but not limited to, its equitable remedy of specific performance. THE FOREGOING NOTWITHSTANDING, NO ENTITY WILL BE LIABLE TO ANOTHER ENTITY OR ANY OF ITS AFFILIATES, AGENTS, EMPLOYEES, OR CONTRACTORS FOR SPECIAL, INDIRECT, EXEMPLARY, INCIDENTAL, PUNITIVE, OR CONSEQUENTIAL DAMAGES.

17. There are no third-party beneficiaries of this WaterLink Project Escrow Agreement and nothing in this WaterLink Project Escrow Agreement, express or implied, is intended to confer on any person other than the Parties hereto (and their respective successors, heirs, and permitted assigns), any rights, remedies, obligations, or liabilities.

18. Any notices under this WaterLink Project Escrow Agreement will be personally delivered, delivered by the deposit thereof in the U. S. Postal Service, postage prepaid, registered, or certified, return receipt requested, or by overnight courier service to the Party at the address listed below or at another address hereafter designated by notice, or by email transmission. Any such notice will be deemed to have been delivered and given upon personal delivery or delivery by a nationally recognized overnight courier service, or deposit with the United States Postal Service or upon receipt of written confirmation that facsimile or email transmission has been successfully completed:

If to the Commission:

Paul D. May, P.E., General Manager
DuPage Water Commission
600 E. Butterfield Road
Elmhurst, IL 60126
Email: may@dpwc.org

With a copy to:

Phillip A. Luetkehans
Luetkehans, Brady, Garner & Armstrong, LLC
105 E. Irving Park Road
Itasca, IL 60143
Email: pal@lbgalaw.com

If to the WaterLink Communities:

Village Administrator
Village of Oswego
100 Parkers Mill
Oswego, IL 60543
Email: info@oswegoil.org

With a copy to:

David J. Silverman
Village Attorney
Mahoney, Silverman, & Cross, LLC
126 South Main Street
Oswego, Illinois 60543

Village Administrator
Village of Montgomery
200 N River Street
Montgomery, IL 60538
Email: zoephel@montgomeryil.org

With a copy to:

Laura M. Julien
Village Attorney
Mickey Wilson, Weiler, Renzi, Lenert, & Julien, PC
140 Municipal Drive
Sugar Grove, IL 60554

City Administrator
United City of Yorkville
800 Game Farm Road
Yorkville, IL 60560
Email: bolson@yorkville.il.us

With a copy to:

Kathleen Field Orr & Associates
Kathleen Field Orr
2024 Hickory Road, Suite 205
Homewood, IL 60430

With a copy to:

Irene Schild Caminer
Caminer Law, LLC
2612 W. Sunnyside Ave.
Chicago, IL 60625
Email: Irene@caminerlaw.com

19. Each WaterLink Community will hold the Commission harmless and defend the Commission from any claims or litigation that arise out of the engineering, construction, property acquisition, and easement acquisitions for the Connection Facilities being constructed for the WaterLink Communities due to one of all of the WaterLink Communities' failure to comply with the payment obligations arising under this WaterLink Project Escrow Agreement.

20. Miscellaneous.

- a. This WaterLink Project Escrow Agreement shall be deemed to supplement the Water Purchase Agreements in connection with the supply of Lake Michigan water to the Waterlink Communities' individual Unit Systems. If there is any other conflict or inconsistency between the terms of this Agreement and the terms of the Water Purchase Agreements, then the terms of this WaterLink Project Escrow Agreement shall control. The WaterLink Communities shall at all times comply with all terms and conditions of the Water Purchase Agreements except as otherwise provided in this Agreement.

- b. Except as provided herein, the WaterLink Communities and the Commission will not assign this WaterLink Project Escrow Agreement or any right or privilege any WaterLink Communities and the Commission may have under this WaterLink Project Escrow Agreement without the prior written consent of all Parties hereto, not to be unreasonably withheld conditioned or delayed.
- c. This WaterLink Project Escrow Agreement shall be governed by and construed exclusively under the applicable laws, but not the conflict of laws rules, of the State of Illinois. Venue for any litigation arising out of this Agreement shall only be proper in the Eighteenth Judicial Circuit Court, DuPage County, Illinois.
- d. The person(s) executing this WaterLink Project Escrow Agreement on behalf of the Parties hereto warrant that: (i) each WaterLink Community and the Commission are duly organized and existing; (ii) the individual signing is duly authorized to execute and deliver this WaterLink Project Escrow Agreement on behalf of said WaterLink Community or the Commission; (iii) by so executing this WaterLink Project Escrow Agreement, such WaterLink Community and the Commission are formally bound to the provisions and conditions contained in this WaterLink Project Escrow Agreement; and (iv) the entering into this WaterLink Project Escrow Agreement by a WaterLink Community and the Commission does not violate any provision of any other agreement to which said WaterLink Community and the Commission is bound.
- e. Each WaterLink Community and the Commission acknowledge that it may be necessary to execute documents other than those specifically referred to herein in order to complete the objectives and requirements that are set forth in this WaterLink Project Escrow Agreement. Each WaterLink Community and the Commission hereby agree to cooperate with each other by executing such other documents or taking such other actions as may be reasonably necessary to complete the objectives and requirements set forth herein in accordance with the intent of each WaterLink Community and the Commission as evidenced by this WaterLink Project Escrow Agreement.

- f. This WaterLink Project Escrow Agreement is the entire agreement between the WaterLink Communities and the Commission regarding its subject matter and may not be changed or amended except pursuant to a written instrument signed by each WaterLink Community and the Commission.
- g. This WaterLink Project Escrow Agreement may be executed in any number of identical counterparts, each of which will be considered an original, but which together will constitute one and the same agreement.

IN WITNESS WHEREOF, each WaterLink Community and the Commission hereto have caused their respective corporate names to be subscribed hereto and their respective corporate seals to be affixed hereto and attested by their duly authorized officers.

ATTEST:

DuPage Water Commission

BY: _____

ATTEST:

Village of Montgomery

BY: _____

ATTEST:

Village of Oswego

BY: _____

ATTEST:

United City of Yorkville

EXHIBIT A

CONNECTION FACILITIES COST

WATERLINK PROJECT ESCROW INTERGOVERNMENTAL AGREEMENT

EXHIBIT A

CONNECTION FACILITIES COST ESTIMATE (1)

CONSTRUCTION (including 25% contingency)	\$210,389,827
PROPERTY INTERESTS/LAND ACQUISITION	\$17,477,530
LEGAL & ADMINISTRATIVE	\$1,000,000
ENGINEERING	\$28,000,000
	<hr/>
	\$256,867,357
COST ESCALATION OVER PROJECT DURATION	\$26,699,000
	<hr/>
ESTIMATED PROJECT COST (2)	\$283,566,357

(1) COST ESTIMATE IS BASED UPON FORECASTED PROJECT COSTS AS OF THE DATE IDENTIFIED BELOW AND IS PROVIDED FOR REFERENCE ONLY. ACTUAL PROJECT COSTS WILL BE BASED UPON AWARDED PROJECT CONTRACT(S) AND ACTUAL REALIZED UNIT PRICE AND LUMP SUM COSTS, INCLUDING PROPERTY ACQUISITION, ENGINEERING, LEGAL AND COMMISSIONING COSTS, ALL OF WHICH HAVE BEEN ESTIMATED HEREIN BUT WILL NOT BE FINALLY DETERMINED UNTIL THE COMPLETION OF THE PROJECT AND FINAL COMMISSIONING.

(2) BASED UPON ESTIMATES INCLUDED IN THE PROJECT DEVELOPMENT REPORT DATED FEBRUARY 1, 2024



Resolution #: R-68-24

Account: N/A

Approvals: *Author / Manager / Finance / Admin*

PDM - - PDM

REQUEST FOR BOARD ACTION

Date: 10/9/2024

Description: **Recommendation to Approve First Amendment to Second Escrow Agreement - WaterLink**

Agenda Section: Administration Committee

Originating Department: Administration

In order to fund Phase I Engineering Activities for the WaterLink Project, an Intergovernmental Escrow Agreement was established, and funds were deposited by the WaterLink communities accordingly. A similar approach was utilized to fund Phase II Engineering Activities (preparation of construction drawings prepared for bid), which is currently underway. Funding for Phase II activities was provided in accordance with the associated Second Escrow Agreement.

During the Phase II engineering activities, it was identified that a proposed IDOT project would precede the WaterLink project and would result in a new storm sewer which would be in conflict with future WaterLink watermain alignment. After discussion with IDOT, a solution was developed which would result in a modification to the IDOT plans to construct the proposed storm sewer in a manner which would accommodate the future alignment for the proposed WaterLink pipeline. This activity consists of modifying the proposed storm sewer material to be watermain quality, which permits the future water pipeline to be constructed within ten feet in a manner compliant with IEPA standards.

This approach provides an opportunity to mitigate a potential future conflict at a significantly lower cost, by the DWC funding the cost of the IDOT storm sewer material revision, rather than revising the future watermain alignment. However, the previously authorized Second Escrow Agreement approved funds for engineering services only. The attached First Amendment to the Second Escrow Agreement permits funds to be utilized for the advanced construction activities as well (IDOT storm sewer). The amendment has been approved by all three WaterLink communities.

Recommended Motion:

It is recommended that the First Amendment to the Second Escrow Agreement be approved.

DUPAGE WATER COMMISSION

RESOLUTION NO. R-68-24

A RESOLUTION APPROVING AN AMENDMENT TO THE WATERLINK SECOND ESCROW INTERGOVERNMENTAL AGREEMENT

WHEREAS, the Commission was formed and exists pursuant to the Water Commission Act of 1985, 70 ILCS 3720/0.01 et seq., and Division 135 of Article 11 of the Illinois Municipal Code, 65 ILCS 5/11-135-1 et seq., for the purpose of securing an adequate source and supply of water for its customers; and

WHEREAS, the Village of Montgomery (“Montgomery”), the Village of Oswego (“Oswego”) and the United City of Yorkville (“Yorkville”) (collectively the “Municipalities”) desire to supply Lake Michigan water to their residents by connecting to the Commission’s waterworks system (the “Project”);

WHEREAS, the Commission previously entered into a contract with Lockwood, Andrews & Newman, Inc. for the second phase of general engineering services related to the Project (the “Phase 2 Services”); and

WHEREAS, the Commission and the Municipalities previously entered into a Second Escrow Intergovernmental Agreement (the “IGA”) to provide for the payment of Phase 2 Services; and

WHEREAS, the Commission and the Municipalities desire and intend to amend the IGA to allow for the funds placed in escrow under the IGA to be utilized to also pay for costs related to and Illinois Department of Transportation project entitled IL Route 71 Gravity Storm Sewer Replacement, which will save significant engineering and construction costs for the Project.

NOW, THEREFORE, BE IT RESOLVED by the Board of Commissioners of the DuPage Water Commission as follows:

SECTION ONE: The Board of Commissioners of the DuPage Water Commission hereby approves the Amendment to the Second Escrow Intergovernmental Agreement attached hereto as Exhibit A and

authorizes the Chairman to execute the agreement on behalf of the DuPage Water Commission and to take whatever steps necessary to effectuate the terms of said agreements.

SECTION TWO: This Resolution shall be in full force and effect after passage and approval as required by law.

	Aye	Nay	Absent	Abstain
Bouckaert, D.				
Cuzzone, N.				
Fennell, J.				
VACANT	_____			
Novotny, D.				
Pruyn, J.				
Romano, K.				
Rush, K.				
Russo, D.				
Saverino, F.				
Suess, P.				
Van Vooren, D.				
Zay, J.				

ADOPTED THIS _____ DAY OF _____, 2024.

James F. Zay, Chairman

ATTEST:

Danna Mundall, Clerk

Board/Resolutions/2024/R-8-24.docx

EXHIBIT A

AMENDMENT TO THE SECOND ESCROW INTERGOVERNMENTAL AGREEMENT

This Amendment to the Second Escrow Intergovernmental Agreement (the “Amendment”) is dated the 19th day of September, 2024 between the Village of Montgomery (“Montgomery”), the Village of Oswego (“Oswego”), and the United City of Yorkville (“Yorkville”) (Oswego, Montgomery, and Yorkville are collectively referred to herein as the “Municipalities”) and the DuPage Water Commission (the “Commission”), a county water commission and public corporation under Division 135 of Article 11 of the Illinois Municipal Code, 65 ILCS 5/11-135-1 *et seq.*, and the Water Commission Act of 1985, 70 ILCS 3720/0.01 *et seq.* (the “Acts”).

WITNESSETH:

WHEREAS, on March 24, 2024, the Commission and the Municipalities entered into the Second Escrow Intergovernmental Agreement (the “IGA”) for the purpose of funding an escrow for Phase 2 engineering services (the “Escrow”); and

WHEREAS, the Commission and the Municipalities are negotiating and intend to enter into a Water Purchase and Sale Contract (the “Water Purchase Agreement”) for the supply of Lake Michigan Water to the Municipalities; and

WHEREAS, as of the date of this amendment the Escrow maintains a sufficient balance and is not expected to need to be replenished before the execution of the Water Purchase Agreement; and

WHEREAS, the Commission is in the process of entering into a Funding Resolution and Letter of Intent (the “Resolution and LOI”) with the Illinois Department of Transportation (“IDOT”) for the modification of an IDOT project entitled IL Route 71 Gravity Storm Sewer Replacement to include a water quality pipe (the “IDOT Project”); and

WHEREAS, the IDOT Project impacts the design and construction of the project to build a connection between the Municipalities and the DWC facilities; and

WHEREAS, the Water Purchase Agreement will not be finalized before the Commission needs to enter into the Resolution and LOI; and

WHEREAS, the IDOT Project will save the Municipalities significant engineering and construction costs as it relates to IEPA and Illinois Pollution Control Board requirements of minimal separation of non-potable water systems from potable water systems; and

WHEREAS, the IGA does not specifically include the ability to pay for construction costs out of the Escrow; and

WHEREAS, the parties deem it to be in their best interests to amend the IGA for Phase 2 engineering services to include the funding of the IDOT Project and allow the Escrow funds to pay for the Phase 2 engineering services, including the IDOT Project.

NOW, THEREFORE, in consideration of the foregoing recitals and of the mutual covenants and agreements herein and other good and valuable consideration, the receipt and sufficiency of which are hereby acknowledged, the IGA is hereby amended as follows:

1. The recitals contained in the Preamble above will become a part of this Amendment to the Second Escrow Agreement as if fully set forth herein.

2. Capitalized terms used, but not otherwise defined herein, shall their respective meanings in the IGA.

3. Section 3 of the IGA is hereby amended to state as follows:

The Commission will establish a segregated Escrow Account for the sole purpose of funding Commission Expenses. The Commission will draw from the Escrow Account to pay for or reimburse the design engineering costs of Commission Expenses along with the costs expended for the Project. Any remaining funds from the First Escrow Agreement will remain in the account and can be utilized for Phase 2 activities.

4. Except as expressly amended by this Amendment, the remaining terms, covenants, conditions, and provisions of the IGA shall remain unchanged and in full force and effect, and this Amendment and the IGA shall constitute the full, true, and complete agreement between the parties.

5. This Amendment shall be binding upon and inure to the benefit of the parties, and their successors and assigns.

6. If any provision of this Amendment is held to be illegal, invalid or unenforceable under present or future laws effective during the term hereof, such provision shall be fully severable. This Amendment shall be construed and enforceable as if the illegal, invalid or unenforceable provision had never comprised a part of it, and the remaining provisions of this Amendment shall remain in full force and effect and shall not be affected by the illegal, invalid or unenforceable provision or by its severance here from. Furthermore, in lieu of such illegal, invalid or unenforceable provision, there shall be added automatically as a part of this Amendment, a provision as similar in terms to such illegal, invalid or unenforceable provision as may be possible and legal, valid and enforceable.

7. This Amendment may be executed in counterparts, each of which shall be deemed an original instrument, but all such counterparts together shall constitute but one agreement. Delivery of an executed counterpart signature page by facsimile or electronic transmittal (PDF) is as effective as executing and delivering this Amendment in the presence of the other parties to this Amendment.

IN WITNESS WHEREOF, each Municipality and the Commission hereto have caused their respective corporate names to be subscribed hereto and their respective corporate seals to be affixed hereto and attested by their duly authorized officers, all on the date set opposite their respective corporate names.

ATTEST:

DuPage Water Commission

BY: _____

ATTEST:

Debra Buchanan

Village of Montgomery

BY: M.T. Boy

ATTEST:

Tina Touchette

Village of Oswego

BY: [Signature]

ATTEST;

[Signature]

United City of Yorkville

BY: [Signature]



Resolution #: N/A

Account: 01-60-659000 \$61,000.00

Approvals: *Author / Manager / Finance / Admin*

JR RCB CAP PDM

REQUEST FOR BOARD ACTION

Date: 9/6/2024

Description: **To Authorizing Approval of Requisition No. 79341 to Hexagon for Annual Maintenance Renewal**

Agenda Section: Administration Committee

Originating Department: Systems & Information Technology

Staff is requesting authorization to contract with Hexagon AB (formerly Infor) for software maintenance and licensing renewal in the amount of approximately \$61,000.

This expense is for the Enterprise Asset Management (EAM) system, the Commission's Computerized Maintenance Management and Purchasing Management Systems, which has been utilized since 2008. The software maintenance and licensing renewal fee is due annually and in addition to licensing for each staff member, provides the Commission with telephone and online product support, patches, revision changes, and program updates.

This expense is budgeted in the Annual Management Budget; Board approval is required due to the sole source service provider.

Recommended Motion:

Authorize the General Manager to approve Requisition No. 79341 in the amount of approximately \$61,000 to Hexagon (formerly Infor).



Print Requisition



Purchase Requisition

Purchase Requisition 79341 [Hexagon Annual Software Maintenance 2025] Requisition Date 09/18/2024

Date Approved

Status U [Unfinished]
For Store DPS [DuPage Pumping Station]
Originator 501-0045 [JENESSA RODRIGUEZ]

Services

Table with 8 columns: Line, Task Plan, Due date, Quantity, UOM, Units, Unit Price, Total. Row 1: 1, , 09/18/2024, 1, UOM, , 60,176.89, 60,176.89 USD

From Supplier HEXAGON [Hexagon]
Work Order - Activity
RFQ
Quotation
Quotation Line

Total 60,176.89 USD

Approver []

Comments

Date

Requisition Comments

RODRIGUEZ [09/18/2024 10:57]:

Annual software maintenance fee for Hexagon (formerly Infor EAM).

Copy of original quote is on the Documents tab.

Due date: Feb 2025

Quote Summary Information
 DUPAGE WATER COMMISSION



Service Site : US00161305
 Site Contact : JENESSA RODRIGUEZ
 Contact Phone :
 Email Address : rodriguez@dpwc.org
 Service Address : 600 E BUTTERFIELD RD
 City/State/Zip : ELMHURST IL 60126
 Country : US

Customer ID : DUPAGE WA/ELMHU US00161305
 Bill To Cust : DUPAGE WATER COMMISSION
 Bill To Address : 600 E BUTTERFIELD RD
 City/State/Zip : ELMHURST IL 60126
 Country : US
 Policy Number : DDCC550F0
 PO Nbr : RENEWAL QUOTE

Service Type : **RENEWAL Q**
 Period of Performance : **02/01/2025 - 01/31/2026**
 Billed on the : 1 st Day of each period
 Period is defined as : Every 12 Months
 Previous Cust Code :
 Previous Contract # :

Total Contract Value : \$ 60,176.89

*** Totals are exclusive of sales tax. This is NOT AN INVOICE.**

Offered By Hexagon ALI

Quote: 0000122644

By : _____
 Name : Kelly Bergfalk
 Email : kelly.bergfalk@hexagon.com
 Address : 305 Intergraph Way
 Madison, AL 35758

Accepted By : _____
 COMPANY : _____
 By : _____
 Name/Title : _____
 POC/Phone : _____
 POC Email : _____
 Date : _____

Issue Date : 09/18/2024

Quotes are valid for 90 days from original date of issue. Quote acceptance after 90 days is at the discretion of Hexagon ALI, a division of Intergraph Corporation.

Messages All services provided hereunder are subject to ALI's Maintenance Service Contract Terms & Conditions (T's & C's) for software (DDCC550F0) unless other specific Terms & Conditions apply and are referenced in the Policy Number field. Copies of the applicable T's & C's may be obtained online at [T's & C's](#). * Totals are exclusive of sales tax - This is NOT AN INVOICE. For coverage code explanations, refer to the last page.

Hexagon ALI

Quote Summary Information
 DUPAGE WATER COMMISSION



Summary Of Service Quote 0000122644

<u>Item Number</u>	<u>Description</u>	<u>QTY</u>	<u>Total Value</u>	<u>Start Date</u>	<u>End Date</u>
EAM00004	HxGN EAM Enterprise Edition for SQL Database NU	1	\$ 962.16	02/01/2025	01/31/2026
EAM00004	HxGN EAM Enterprise Edition for SQL Database NU	5	\$ 2,849.28	02/01/2025	01/31/2026
EAM00004	HxGN EAM Enterprise Edition for SQL Database NU	35	\$ 48,470.08	02/01/2025	01/31/2026
EAM00014	HxGN EAM Enterprise Edition Barcoding NU	1	\$ 485.94	02/01/2025	01/31/2026
EAM00019	HxGN EAM Enterprise Edition Advanced Reporting Consumer NU	1	\$ 75.24	02/01/2025	01/31/2026
EAM00019	HxGN EAM Enterprise Edition Advanced Reporting Consumer NU	5	\$ 222.60	02/01/2025	01/31/2026
EAM00019	HxGN EAM Enterprise Edition Advanced Reporting Consumer NU	35	\$ 4,950.36	02/01/2025	01/31/2026
EAM00035	HxGN EAM Enterprise Edition Requestor DA	2	\$ 164.23	02/01/2025	01/31/2026
EAM00356	HxGN EAM Enterprise Edition Mobile DV	3	\$ 1,997.00	02/01/2025	01/31/2026
Grand Total :			\$ 60,176.89		

Quote Summary Information
DUPAGE WATER COMMISSION



<u>LI</u>	<u>Sts</u>	<u>Item Number</u>	<u>Description</u>	<u>Serial Number</u>	<u>Start Date</u>	<u>End Date</u>	<u>Coverage</u>	<u>QTY</u>	<u>Ext. Price</u>	<u>Cancel Flag</u>
100		EAM00019	HxGN EAM Enterprise Edition Advanced Reporting Consumer NU	A109497	02/01/2025	01/31/2026	PREM	1	\$ 75.24	
200		EAM00019	HxGN EAM Enterprise Edition Advanced Reporting Consumer NU	B109497	02/01/2025	01/31/2026	PREM	35	\$ 4,950.36	
300		EAM00014	HxGN EAM Enterprise Edition Barcoding NU	C109497	02/01/2025	01/31/2026	PREM	1	\$ 485.94	
500		EAM00356	HxGN EAM Enterprise Edition Mobile DV	E109497	02/01/2025	01/31/2026	PREM	3	\$ 1,997.00	
600		EAM00035	HxGN EAM Enterprise Edition Requestor DA	F109497	02/01/2025	01/31/2026	PREM	2	\$ 164.23	
700		EAM00004	HxGN EAM Enterprise Edition for SQL Database NU	G109497	02/01/2025	01/31/2026	PREM	1	\$ 962.16	
800		EAM00004	HxGN EAM Enterprise Edition for SQL Database NU	H109497	02/01/2025	01/31/2026	PREM	35	\$ 48,470.08	
900		EAM00004	HxGN EAM Enterprise Edition for SQL Database NU	I109497	02/01/2025	01/31/2026	PREM	5	\$ 2,849.28	
1000		EAM00019	HxGN EAM Enterprise Edition Advanced Reporting Consumer NU	J109497	02/01/2025	01/31/2026	PREM	5	\$ 222.60	

Quote Summary Information
DUPAGE WATER COMMISSION



Quote Line Notes:

Coverage Code Definitions:

PREM: Premium Service. A monthly maintenance charge. Includes telephone support, bulletin board support and upgrades when made available by Hexagon ALI or a Third Party Software Vendor.



MEMORANDUM

To: Paul May – General Manager

From: Chris Bostick – Manager of Water Operations
Jeff Loster – Manager of Engineering

Mike Weed – Operations & Instrumentation Supervisor
Dariusz Panaszek – Pipeline & Remote Facilities Supervisor
Denis Cuvalo – Systems Engineer and Information Technology Supervisor

Date: 10/10/2024

Subject: Status of Operations, Engineering and Construction

Operations Overview

The Commission's sales for September 2024 were a total of 2.64 billion gallons. This represents an average daily demand of 87.8 million gallons per day (MGD), which is higher than the September 2023 average day demand of 80.5 MGD. The maximum day demand was 101.3 MGD recorded on September 16, 2024, which is lower than the September 2023 maximum day demand of 103.3 MGD. The minimum day flow was 75.6 MGD.

The recorded total precipitation for September 2024 was 1.32 inches compared to 3.36 inches for September 2023. The level of Lake Michigan for September 2024 is 579.30 (Feet International Great Lakes Datum (IGLD) 1985) compared to 579.17 (Feet IGLD 1985) for September 2023.

DuPage Operations & Instrumentation Maintenance and Construction Overview

The 2024 Meter Testing Program is in process and 63% complete.

High Lift Pump #7 outboard mechanical seal was rebuilt due to end-of-life service. The pump was placed back in service.

Preventive maintenance was performed on the 5kv High Lift Pump Motor starters.

City of Chicago Water Treatment Modifications

The Illinois EPA released a form letter to all water systems that receive Lake Michigan water via the City of Chicago's two water treatment plants. The letter advised the recipients that the City will be transitioning in October from their current blended phosphate to phosphoric

acid to optimize the control of lead and copper release through household plumbing. The letter suggested that each water system employ unidirectional flushing of their individual systems and perform sentinel monitoring for the lead and copper as well as other compounds, before, during and after the transitional period.

DWC Staff believes that while we are confident the proposed treatment change is appropriate and has been properly vetted by the City of Chicago and the IEPA, there remains an absence of information and specific guidance for DWC Customers. Staff has reached out to various parties to facilitate the cohesive and consistent communication of activities, and the development of specific operational recommendations associated with the Chicago treatment change.

DWC Staff has received a draft report from Dr. David Cornwell, PhD, of the Cornwell Engineering Group, having completed his review of the Chicago study which includes recommendations regarding DWC and DWC Customer operations during the transition. DWC Staff has initiated the monitoring of certain water quality parameters to follow the progress during the City's modification of the treatment technique. The City, their consultants and IEPA have held informational webinars for their customer base and their respective consultants on September 23rd and 24th.

Lexington Operations and Maintenance Overview

Staff continues to discuss with the Department of Water Management Staff (DWM) the content of the 2023 Lexington Pump Station Condition Assessment and other emerging issues. Previous discussions focused on the Pumping System Vibration Analysis equipment and the installation to replace the erstwhile analytical equipment. Investigations continue and additional proposals are being sought for the installation of vibration analysis instrumentation; proposals will be brought forth for Board consideration in the near future.

The Photovoltaic Systems (PV System) evaluation reports have been received by staff. The reports indicate the planning level estimates to return the PV system to full functionality and propose potential enhancements for consideration.

DWM reports they continue to troubleshoot their SCADA system deficiencies however have not been able to identify the root cause of the ongoing issue to date.

Alternate Water Source

Christopher B. Burke Engineering, Ltd. (CBBEL) continues the process of developing a preliminary site plan for the Northbrook property. Staff has met with CBBEL to discuss preliminary site stormwater management strategies, grading, utility and interim landscaping plans.

Staff continues to maintain the site grass below the ordained height of the Village of Northbrook zoning regulations, and the driveway barrier gates have been installed.

Pipeline & Remote Facilities Maintenance Overview

Pipeline staff continue inspecting Remote Facilities and performing maintenance and corrective work as needed including meter station site drainage improvements and various valve actuator repairs.

Pipeline staff is working with Rossi Contractors, Inc. repairing and replacing frames and lids at locations listed in the Work Authorization Order No. 27.

Pipeline staff continue monitoring I-294 (NB and SB) Tollway construction work in the vicinity of the Commission's 72-inch and 90-inch water mains.

Resolution R-54-24 appears on agenda to authorize the General Manager to purchase hydro-vacuum cleaning services from Badger Hydrovac Service at a cost not to exceed \$30,000. The purpose of the purchase is to maintain the interiors of various Air Release Valve Vaults.

SCADA & Information Technology Overview

The SCADA Replacement Project (Contract PSD-9/21) is ongoing. Resolution R-56-24 appears on the agenda as Change Order No. 05 for necessary modifications to the Work at a net cost increase of \$31,122.00, revising the total Contract Price to \$15,577,720.83, resulting in a net increase in the Contract Value by 0.2%. The DWC campus control panel replacement has been completed with final site acceptance testing and open items work being completed. The Factory Acceptance Test (FAT) for the remote site control panels including Lexington and the Tank Sites is scheduled for November. The inspection and maintenance of all remote site antenna systems is underway and progressing well and is anticipated to be completed by the end of the year, ~ 55% complete. Replacement of the fiber network for the DWC campus is anticipated to begin late this Fall following the completion of all control and network upgrades with the addition of a new duct bank to complete a ring topology for the new fiber network. The Back-Up Telemetry System radio and processor upgrade has been completed and tested. Access Control security system upgrade is scheduled for December.

Engineering & Capital Improvement Program Overview

The DPPS Emergency Generation System Modifications (Contract PSD-10/22) Project has been completed. A final balancing change order will be brought forward in November for final approval, after which the project will be closed out. At this time, the final cost of the project is anticipated to represent an increase of approximately 3% over the initial contract award amount. All completed work will continue to be monitored throughout the two-year warranty period.

WaterLink Communities (Montgomery/Oswego/Yorkville)

The Phase II engineering effort remains ongoing and is approximately 45% complete. Preliminary field work (utility potholing, soil borings, etc.) is nearly complete, with the only areas remaining being those within the ComEd corridor. Commission Staff and the design team continue to hold weekly calls with ComEd Staff to ensure an efficient design that is optimal for all parties. At this time, all submittals to ComEd have been made and are currently under review.

Commission Staff continues to work diligently with the WaterLink communities to coordinate information exchanges that remain critical in establishing terms of important documents such as the Subsequent Customer Agreements, Construction Escrow Agreements and the buy-in fee calculations.

Recently, a workshop was held with the design team to further refine project details involving valve vaults as well as meter station piping and a separate meeting was held with Indian Prairie School District 204 Staff to discuss construction along Book Road and the associated detours that will impact their bus routes.

The corrosion control treatment study, performed by the Cornwell Engineering Group, is ongoing with the acclimation phase scheduled to be completed at the end of the year. The study is performed by flowing water through residential pipe segments harvested from the WaterLink communities to analyze how the transition in water sources will impact things like lead concentrations, pH, alkalinity, etc. Upon completion of the acclimation phase, water from the Jardine Water Purification Plant will then be recirculated through the pipe segments to simulate the transition in water sources and further analysis will be performed. This study is required by the Illinois Environmental Protection Agency (IEPA) and is expected to be completed in October 2025.

Commission Staff also recently issued a Request for Qualifications for Phase III (construction engineering) services on the WaterLink Project. It is anticipated that multiple consulting firms will be involved in the Phase III effort, assigned to various portions of the project based on construction bid package divisions. Submittals of Qualifications (RFQs) are due on October 25th, after which time Commission staff will review and establish a short-list of firms. Subsequent Requests for Proposals (RFPs) will then be issued to the short-listed firms as deemed appropriate by Commission Staff.

Board Action Items

Resolution R-54-24: A Resolution Approving Hydro-Vacuum Cleaning Services (**Badger Daylighting Corp. – Not-To-Exceed \$30,000**)

Resolution R-56-24: A Resolution Approving and Ratifying Certain Change Orders to a Contract for the SCADA Replacement Project (Contract PSD-9/21) (**Baxter & Woodman/Boller Construction – Revising the Contract Price from \$15,546,598.83 to \$15,577,720.83**)

Attachments

1. DuPage Laboratory Bench Sheets for September 2024
2. Water Sales Analysis 01-May-2020 to 30-September-2024
3. DuPage Water Commission Chart Sales vs. Historical Average
4. DuPage Water Commission Chart Sales vs. Allocation
5. WaterLink Status Report

DU PAGE WATER COMMISSION
WATER SALES ANALYSIS

01-May-92 TO 30-Sep-24

PER DAY AVERAGE 77,971,848

MONTH	SALES TO CUSTOMERS (GALLONS)	PURCHASES FROM CHICAGO (GALLONS)	GALLONS BILLED %	BILLINGS TO CUSTOMERS	BILLINGS FROM CHICAGO	DOCUMENTED WATER USE (2)	DOCUMENTED COMMISSION WATER USE %	TOTAL ACCOUNTED FOR %	DWC OPER. & MAINT. RATE (3)	CHGO RATE
May-20	2,084,924,000	2,141,838,951	97.34%	\$10,362,072.28	\$8,513,809.83	376,100	0.02%	97.36%	\$4.97	\$3.975
Jun-20	2,522,634,000	2,596,146,493	97.17%	\$12,537,490.98	\$10,571,508.52	731,078	0.03%	97.20%	\$4.97	\$4.072
Jul-20	2,782,507,000	2,872,440,835	96.87%	\$13,829,059.79	\$11,696,579.08	647,000	0.02%	96.89%	\$4.97	\$4.072
Aug-20	3,078,522,000	3,180,137,701	96.80%	\$15,300,254.34	\$12,949,520.72	3,694,350	0.12%	96.92%	\$4.97	\$4.072
Sep-20	2,427,570,000	2,510,646,051	96.69%	\$12,065,022.90	\$10,223,350.72	1,148,848	0.05%	96.74%	\$4.97	\$4.072
Oct-20	2,143,671,000	2,203,255,879	97.30%	\$10,654,044.87	\$8,971,657.94	748,000	0.03%	97.33%	\$4.97	\$4.072
Nov-20	1,897,985,000	1,957,960,123	96.94%	\$9,432,985.45	\$7,972,813.62	200,026	0.01%	96.95%	\$4.97	\$4.072
Dec-20	1,955,711,000	2,027,160,874	96.48%	\$9,719,883.67	\$8,254,599.08	348,955	0.02%	96.49%	\$4.97	\$4.072
Jan-21	1,988,344,000	2,040,857,402	97.43%	\$9,882,069.68	\$8,310,371.34	205,828	0.01%	97.44%	\$4.97	\$4.072
Feb-21	1,915,366,000	1,971,858,620	97.14%	\$9,519,369.02	\$8,029,408.30	290,224	0.01%	97.15%	\$4.97	\$4.072
Mar-21	1,986,888,000	2,055,661,022	96.65%	\$9,874,833.36	\$8,370,651.68	512,237	0.02%	96.68%	\$4.97	\$4.072
Apr-21	1,959,759,000	2,010,756,459	97.46%	\$9,740,002.23	\$8,187,800.30	1,013,926	0.05%	97.51%	\$4.97	\$4.072
May-21	2,331,364,000	2,401,447,849	97.08%	\$11,586,879.08	\$9,778,695.64	1,625,835	0.07%	97.15%	\$4.97	\$4.072
Jun-21	2,646,312,000	2,727,518,236	97.02%	\$13,152,170.64	\$11,226,465.06	872,815	0.03%	97.05%	\$4.97	\$4.116
Jul-21	2,661,520,000	2,750,318,994	96.77%	\$13,227,754.40	\$11,320,312.98	772,815	0.03%	96.80%	\$4.97	\$4.116
Aug-21	2,736,795,000	2,818,422,046	97.10%	\$13,601,871.15	\$11,600,625.14	458,555	0.02%	97.12%	\$4.97	\$4.116
Sep-21	2,616,212,000	2,698,022,374	96.97%	\$13,002,573.64	\$11,105,060.09	1,237,080	0.05%	97.01%	\$4.97	\$4.116
Oct-21	2,128,141,000	2,179,013,387	97.67%	\$10,576,860.77	\$8,968,819.10	396,147	0.02%	97.68%	\$4.97	\$4.116
Nov-21	1,896,311,000	1,961,815,221	96.66%	\$9,424,665.67	\$8,074,831.45	462,613	0.02%	96.68%	\$4.97	\$4.116
Dec-21	1,950,793,000	2,010,917,641	97.01%	\$9,695,441.21	\$8,276,937.01	382,031	0.02%	97.03%	\$4.97	\$4.116
Jan-22	2,046,043,000	2,110,214,643	96.96%	\$10,168,833.71	\$8,685,674.26	621,078	0.03%	96.99%	\$4.97	\$4.116
Feb-22	1,879,376,000	1,935,513,559	97.10%	\$9,340,498.72	\$7,966,573.81	247,750	0.01%	97.11%	\$4.97	\$4.116
Mar-22	1,990,472,000	2,061,912,643	96.54%	\$9,892,645.84	\$8,486,832.44	459,838	0.02%	96.56%	\$4.97	\$4.116
Apr-22	1,935,992,000	1,981,414,298	97.71%	\$9,621,880.24	\$8,155,501.25	285,652	0.01%	97.72%	\$4.97	\$4.116
May-22	2,276,513,000	2,344,221,635	97.11%	\$11,792,337.34	\$9,648,816.25	5,698,667	0.24%	97.35%	\$5.18	\$4.116
Jun-22	2,682,480,000	2,772,533,130	96.75%	\$13,895,246.40	\$11,982,888.19	690,925	0.02%	96.78%	\$5.18	\$4.322
Jul-22	2,804,661,000	2,892,532,635	96.96%	\$14,528,143.98	\$12,501,526.05	883,858	0.03%	96.99%	\$5.18	\$4.322
Aug-22	2,688,224,000	2,772,533,130	96.96%	\$13,925,000.32	\$11,982,888.19	906,806	0.03%	96.99%	\$5.18	\$4.322
Sep-22	2,415,535,000	2,474,643,822	97.61%	\$12,512,471.30	\$10,695,410.60	1,021,063	0.04%	97.65%	\$5.18	\$4.322
Oct-22	2,153,410,000	2,220,050,683	97.00%	\$11,154,663.80	\$9,595,059.05	2,891,786	0.13%	97.13%	\$5.18	\$4.322
Nov-22	1,919,552,000	1,979,550,491	96.97%	\$9,943,279.36	\$8,555,617.22	1,008,092	0.05%	97.02%	\$5.18	\$4.322
Dec-22	2,071,113,000	2,123,449,660	97.54%	\$10,728,365.34	\$9,177,549.43	552,389	0.03%	97.56%	\$5.18	\$4.322
Jan-23	2,014,750,000	2,060,255,805	97.79%	\$10,436,405.00	\$8,904,425.59	337,423	0.02%	97.81%	\$5.18	\$4.322
Feb-23	1,835,597,000	1,883,158,917	97.47%	\$9,508,392.46	\$8,139,012.84	529,206	0.03%	97.50%	\$5.18	\$4.322
Mar-23	1,971,974,000	2,026,257,691	97.32%	\$10,214,825.32	\$8,757,453.41	306,690	0.02%	97.34%	\$5.18	\$4.322
Apr-23	1,962,197,000	2,010,451,747	97.60%	\$10,164,180.46	\$8,689,172.45	349,596	0.02%	97.62%	\$5.18	\$4.322
May-23	2,474,377,000	2,540,440,833	97.40%	\$13,336,892.03	\$10,979,785.28	684,441	0.03%	97.43%	\$5.39	\$4.322
Jun-23	2,971,436,000	3,043,540,086	97.63%	\$16,016,040.04	\$13,814,628.45	678,930	0.02%	97.65%	\$5.39	\$4.539
Jul-23	2,567,425,000	2,639,887,376	97.26%	\$13,838,420.75	\$11,982,448.80	1,047,600	0.04%	97.29%	\$5.39	\$4.539
Aug-23	2,708,945,000	2,773,069,509	97.69%	\$14,601,213.55	\$12,586,962.50	832,992	0.03%	97.72%	\$5.39	\$4.539
Sep-23	2,406,858,000	2,471,708,096	97.38%	\$12,972,964.62	\$11,219,083.05	753,904	0.03%	97.41%	\$5.39	\$4.539
Oct-23	2,071,291,000	2,116,545,770	97.86%	\$11,164,258.49	\$9,607,001.25	1,034,131	0.05%	97.91%	\$5.39	\$4.539
Nov-23	1,902,725,000	1,957,768,374	97.19%	\$10,255,687.75	\$8,886,310.65	809,342	0.04%	97.23%	\$5.39	\$4.539
Dec-23	1,972,754,000	2,031,158,416	97.12%	\$10,633,144.06	\$9,219,428.05	2,329,064	0.11%	97.24%	\$5.39	\$4.539
Jan-24	2,058,390,000	2,131,445,175	96.57%	\$11,094,722.10	\$9,674,663.60	730,427	0.03%	96.61%	\$5.39	\$4.539
Feb-24	1,868,175,000	1,916,869,806	97.46%	\$10,069,463.25	\$8,700,672.05	268,834	0.01%	97.47%	\$5.39	\$4.539
Mar-24	1,927,795,000	1,971,770,225	97.77%	\$10,390,815.05	\$8,949,831.10	340,529	0.02%	97.79%	\$5.39	\$4.539
Apr-24	1,951,120,000	1,992,959,991	97.90%	\$10,516,636.80	\$9,046,045.40	426,636	0.02%	97.92%	\$5.39	\$4.539
May-24	2,285,252,000	2,331,031,384	98.04%	\$12,751,706.16	\$10,580,551.45	964,148	0.04%	98.08%	\$5.58	\$4.539
Jun-24	2,558,136,000	2,613,555,125	97.88%	\$14,274,398.88	\$12,265,414.20	669,121	0.03%	97.91%	\$5.58	\$4.693
Jul-24	2,577,734,000	2,637,750,416	97.72%	\$14,383,755.72	\$12,378,962.70	5,976,667	0.23%	97.95%	\$5.58	\$4.693
Aug-24	2,723,982,000	2,791,119,391	97.59%	\$15,199,819.56	\$13,098,723.30	5,570,100	0.20%	97.79%	\$5.58	\$4.693
Sep-24	2,607,811,000	2,668,243,213	97.74%	\$14,551,585.38	\$12,522,065.40	887,220	0.03%	97.77%	\$5.58	\$4.693
TOTALS (1)	923,264,653,798	949,790,739,176	97.21%	\$2,358,442,264.46	\$2,080,944,314.45	885,576,226	0.09%	97.30%	\$2.55	\$2.191

- (1) - SINCE MAY 1, 1992
- (2) - REPRESENTS DU PAGE PUMP STATION, METER TESTING AND CONSTRUCTION PROJECT USAGE
- (3) - DOES NOT INCLUDE FIXED COST PAYMENTS

YTD

Sep-23	13,129,041,000	13,468,645,900	97.48%	70,765,531	60,582,908				\$5.39	\$4.498
Sep-24	12,752,915,000	13,041,699,529	97.79%	71,161,266	60,845,717				\$5.58	\$4.665
	(376,126,000)	(426,946,371)		\$395,735	\$262,809					
	-2.9%	-3.2%		0.6%	0.4%					
Month										
Sep-23	2,406,858,000	2,471,708,096	97.38%	12,972,965	11,219,083				\$5.39	\$4.539
Sep-24	2,607,811,000	2,668,243,213	97.74%	14,551,585	12,522,065				\$5.58	\$4.693
	200,953,000	196,535,117		\$1,578,621	\$1,302,982					
	8.3%	8.0%		12.2%	11.6%					
Sept>Aug	(116,171,000)	(122,876,178)		(648,234)	(576,658)					

DUPAGE WATER COMMISSION
 PWS FACILITY ID# - IL435400
 MONTHLY OPERATIONS REPORT
 DUPAGE WATER COMMISSION LABORATORY BENCH SHEET RESULTS
 SEPTEMBER 2024

DATE	LEXINGTON P.S. SUPPLY				DUPAGE P.S. DISCHARGE							ANALYST INT.
	FREE Cl2 (mg/L)	TURBIDITY (ntu)	O-PO4 (mg/L)	FREE Cl2 (mg/L)	TURBIDITY (ntu)	TEMP (°F)	pH	Fluoride (mg/L)	O-PO4 (mg/L)	P.A.C. (LBS/MG)		
1	1.25	0.11	0.67	1.14	0.11	73	7.3	0.7	0.69	0	RC	
2	1.22	0.10	0.65	1.09	0.11	73	7.2	0.7	0.68	0	KD	
3	1.29	0.12	0.64	1.20	0.10	72	7.2	0.7	0.66	0	KD	
4	1.30	0.13	0.66	1.33	0.13	73	7.3	0.7	0.63	0	RC	
5	1.04	0.12	0.67	1.18	0.13	73	7.3	0.7	0.62	0	RC	
6	1.32	0.13	0.64	1.17	0.13	73	7.3	0.7	0.63	0	RC	
7	1.18	0.13	0.63	1.24	0.15	73	7.1	0.7	0.63	0	KD	
8	1.10	0.14	0.64	1.15	0.12	73	7.1	0.7	0.63	0	KD	
9	1.03	0.12	0.61	1.14	0.13	72	7.3	0.7	0.63	0	RC	
10	1.22	0.12	0.63	1.25	0.13	71	7.3	0.7	0.61	0	RC	
11	1.30	0.12	0.65	1.31	0.11	71	7.1	0.7	0.62	0	KD	
12	1.34	0.12	0.64	1.23	0.11	71	7.2	0.7	0.64	0	KD	
13	1.27	0.14	0.68	1.23	0.13	71	7.2	0.7	0.66	0	KD	
14	1.43	0.11	0.61	1.33	0.11	71	7.2	0.8	0.60	0	RC	
15	1.28	0.09	0.57	1.22	0.11	71	7.2	0.7	0.62	0	RC	
16	1.11	0.15	0.61	1.18	0.11	72	7.1	0.6	0.58	0	KD	
17	1.18	0.10	0.57	1.27	0.10	72	7.1	0.7	0.60	0	KD	
18	1.31	0.09	0.58	1.18	0.11	72	7.2	0.7	0.60	0	RC	
19	1.27	0.08	0.58	1.16	0.11	72	7.2	0.8	0.61	0	RC	
20	1.27	0.09	0.62	1.20	0.14	72	7.2	0.7	0.63	0	RC	
21	1.29	0.11	0.64	1.22	0.13	73	7.1	0.7	0.64	0	AM	
22	1.32	0.13	0.63	1.24	0.14	73	7.1	0.7	0.61	0	AM	
23	1.23	0.08	0.58	1.23	0.10	72	7.2	0.7	0.57	0	RC	
24	1.19	0.10	0.62	1.20	0.10	72	7.3	0.7	0.60	0	RC	
25	1.20	0.10	0.64	1.29	0.10	72	7.2	0.7	0.62	0	AM	
26	1.18	0.10	0.62	1.21	0.11	72	7.2	0.7	0.63	0	AM	
27	1.13	0.11	0.65	1.18	0.11	72	7.2	0.7	0.64	0	AM	
28	1.29	0.10	0.67	1.16	0.12	71	7.2	0.6	0.68	0	JS	
29	1.19	0.11	0.65	1.19	0.11	71	7.2	0.6	0.65	0	JS	
30	1.28	0.09	0.63	1.21	0.11	71	7.2	0.7	0.63	0	AM	
31												
AVG.	1.23	0.11	0.63	1.21	0.12	72	7.2	0.7	0.63	0		
MAX.	1.43	0.15	0.68	1.33	0.15	73	7.3	0.8	0.69	0		
MIN.	1.03	0.08	0.57	1.09	0.10	71	7.1	0.6	0.57	0		

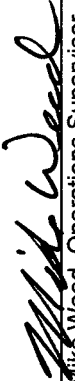
 Date 10/3/24
 Mike Weed, Operations Supervisor
 Illinois ROINC # 186860234

DU PAGE WATER COMMISSION SALES FY 2024-25, 2023-24 & 2022-23 VS. HISTORICAL AVERAGE

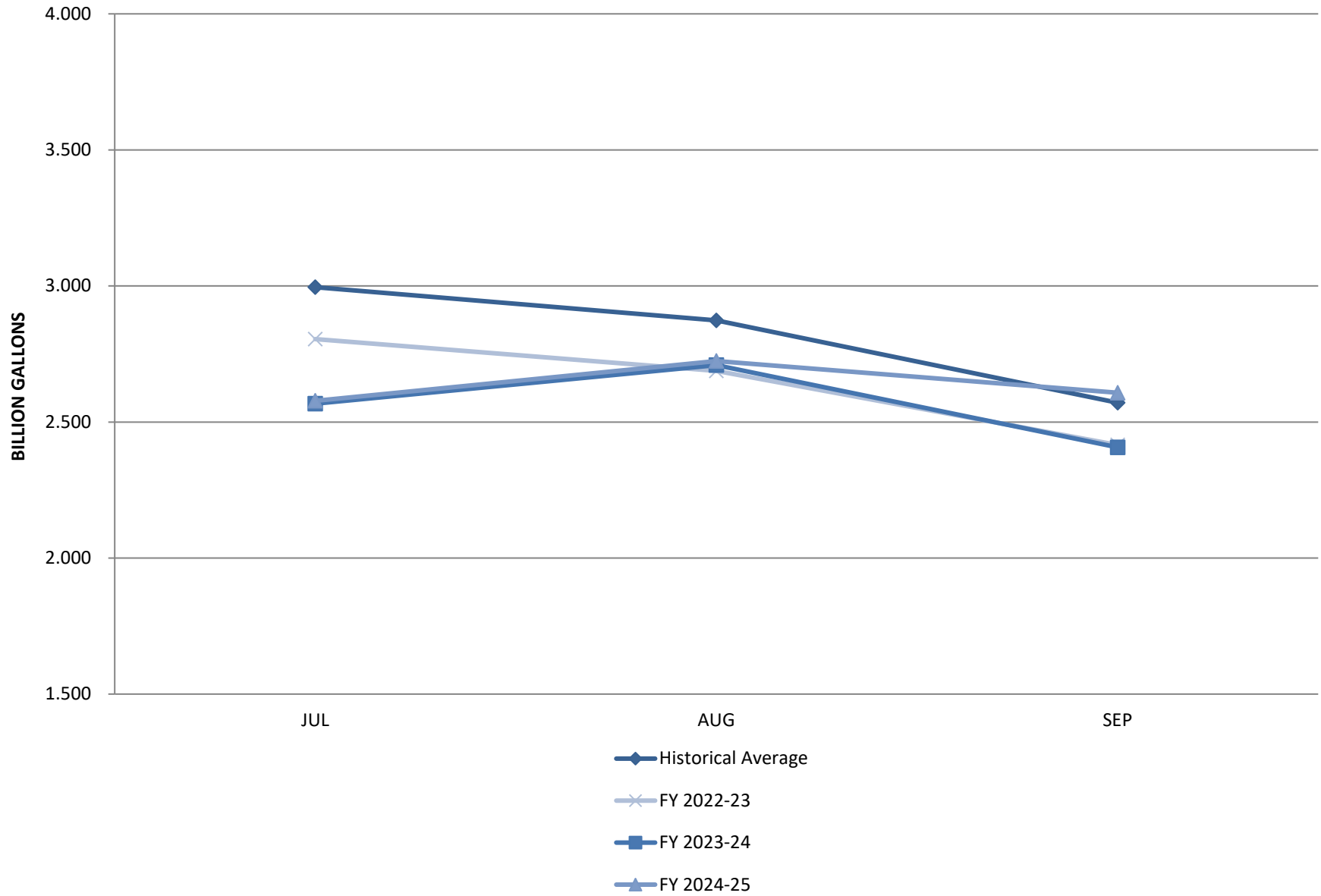

DU PAGE WATER COMMISSION SALES FY 2024-25 VS. ALLOCATION

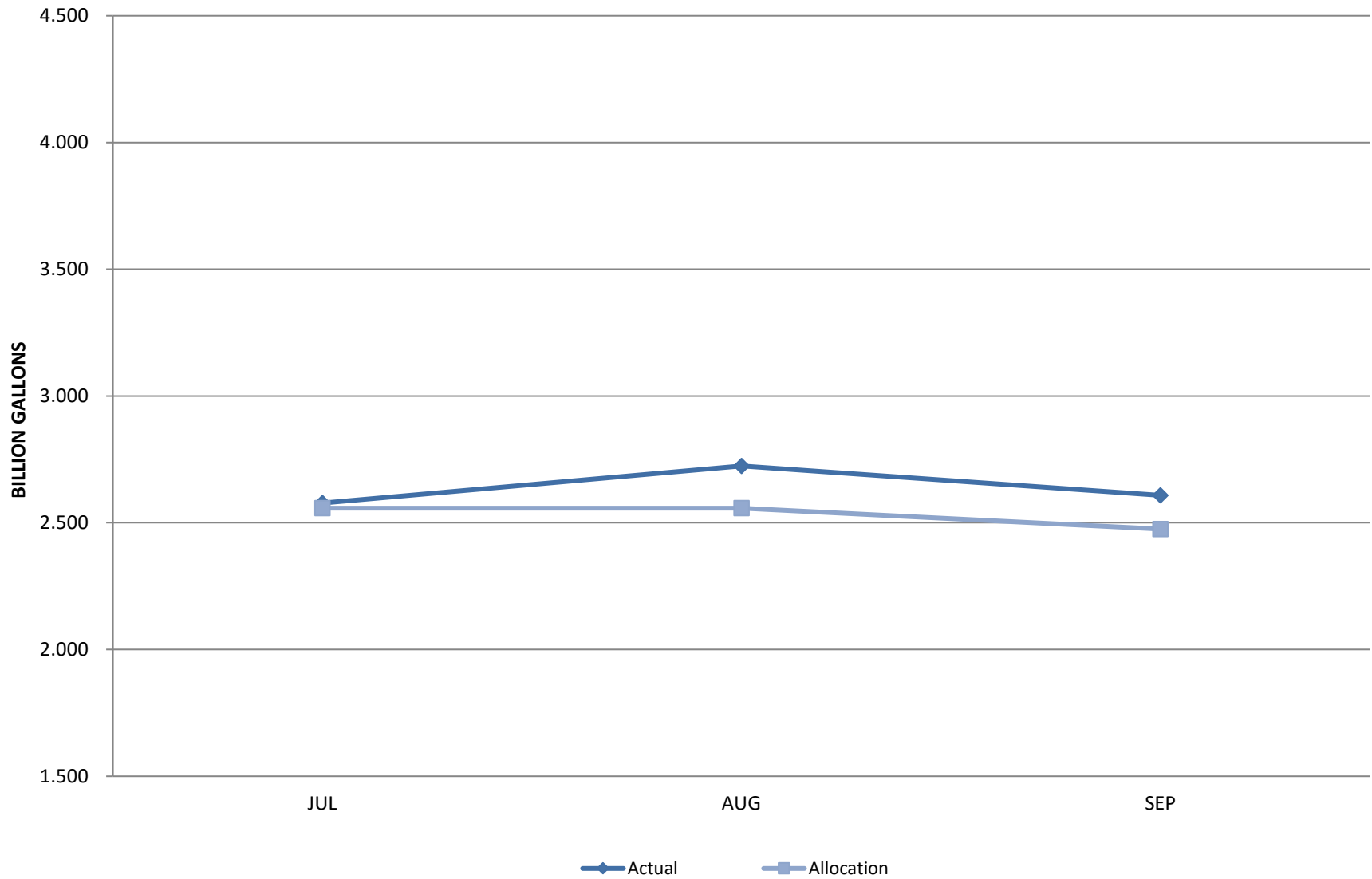



MONTHLY STATUS REPORT

LAN PROJECT #: 128-10031-001

PROJECT: DuPage Water Commission WaterLink Extension Phase II

REPORT DATE: October 7, 2024

MEETING DATE: October 17, 2024

I. Progress through October 7, 2024

A. Field data collection and surveying.

1. Final cadastral surveying work ongoing.
 - a) All 13 additional sections authorized in Phase 1 complete. Site surveying for 3 of the 7 delivery sites has been completed, with remainder coming from WaterLink municipal engineers.
 - b) Site topo at Oswego East HS began Aug 6 and is complete. High school engineer provided existing utility map at site.
 - c) Existing structure rim/invert data collection 100% complete. Total of approximately 1,050 structures located with rim/inverts surveyed.
2. Processing of collected Aerial LIDAR data is complete.
 - a) 100% of original scope complete. Overall width of data processing increased to facilitate design drawing set-up and minimize future re-work. Increased width processing complete.
 - b) SAM delivered additional processed data along Wolf's Crossing Rd and Douglas Rd for modified FW1 Segment 1 & 2 route to REL on August 26th.
3. Subsurface Utility Locates
 - a) All SUE field activities completed.
4. Utility Potholing Locates
 - a) Over 400 potholes completed to date and are about 90% complete. Subconsultant pulled off job until ComEd approval is granted for subsurface work in its ROW.
5. Geotechnical
 - a) Total of 96 borings (48%) completed to date in Phase 2.
 - b) Two remaining borings at 75th Street and Book Road to be drilled next week. Received DuPage County permit on 10/8/24.
 - c) Awaiting permits from ComEd and IDOT before remobilizing to complete remainder.



Planning
Engineering
Program Management





MONTHLY STATUS REPORT

- d) Book Road draft geotechnical report submitted to Design Team for review.
- 6. Cathodic Protection
 - a) Soil resistivity testing underway for cathodic protection design.
 - b) Crew has mobilized and begun data collection along Book Road.
- B. Data Collection (as-builts, GIS, design drawings).
 - 1. Data collection ongoing for IL Route 71 and IL Route 30.
 - 2. WaterLink Delivery Point proposed site layouts.
 - 3. Additional title commitments have been ordered along US Route 30, Wolf's Crossing, Douglas Rd.
 - 4. Design team has set initial priority parcels to move to the plat preparation stage.
- C. Ongoing Coordination with ComEd.
 - 1. Coordination with ComEd ongoing to address transmission main alignment review comments.
 - a) ComEd provided preliminary approval for alignment east of Ogden Falls Blvd (TW6 Section 2).
 - 1) Written (email) approval of the alignment has been received and the team is waiting on approval for geotechnical and potholing work within ComEd property.
 - b) ComEd requested transmission main additional alignment revisions for alignment west of Ogden Falls Blvd (TW6 Section 3).
 - 1) Revised pipeline alignment, including proposed geotechnical and potholing locations have been submitted to ComEd for review on 9/30/24.
 - 2. Subsequent ComEd design reviews and coordination will be performed during Phase II design as part of legal and appraisal process.
- D. Contract TW6 Section 1 (Book Rd) in progress.
 - 1. Water transmission main plan and profile design ongoing.
 - 2. Proposed connection design at Book Road & 75th Street.
 - 3. Remote operated valves to be placed along existing 48-inch transmission main.
 - 4. Preliminary roadway plans and traffic control plans have been prepared.
- E. Contract TW6 Section 2 & 3 in progress.
 - 1. Water transmission main plan and profile design ongoing.
 - 2. Drawing production underway after receiving preliminary approval from ComEd Transmission Engineering group for TW6 Section 2.



Planning
Engineering
Program Management





MONTHLY STATUS REPORT

3. TW6 Section 3 drawing production on hold pending alignment revisions and subsequent reviews by ComEd.
- F. Contract FW1 Section 1 & 2 in progress.
1. Water transmission main plan and profile design ongoing. Realignment design through Oswego East High School site and along Wolf's Crossing / Douglas Road in progress.
 - a) Additional geotechnical investigation pending.
- G. Contract FW1 Section 3 in progress.
1. Water transmission main plan and profile design ongoing.
 2. Ongoing coordination with IDOT District 3 on IL Route 71 project overlap.
- H. Contract FW1 Section 4 in progress.
1. Water transmission main plan and profile design ongoing.
 - a) Orchard Road, Tuscany Trail, Galena Road, IL Route 30.
- I. Contract MS22 Meter Stations in progress.
1. Meter station piping and building layouts ongoing.
 2. Ongoing coordination w/ DWC regarding layouts and preliminary information for subsequent customer agreements.
 3. Architectural and structural design for the buildings is ongoing.

II. Scope Changes – Phase II (to date)

N/A

III. Financials

- A. Total Phase II Contract: \$19,956,942
1. Fee Expended through September 30, 2024:
 - a) Total: \$8,929,247 (44.7%)
 - 1) Basic Services: \$5,455,206 (27.2%)
 - 2) Additional Services: \$3,494,731 (17.5%)



Planning
Engineering
Program Management





MONTHLY STATUS REPORT

IV. Completed Workshops, Meetings and Visits (September—October)

- A. Hydraulics and Construction Coordination Meeting w/ DWC, Montgomery, and Yorkville – September 5, 2024
- B. Monthly Progress Meeting w/ DWC – September 19, 2024
- C. ComEd realignment design review w/ DWC – September 24, 2024
- D. Pipeline Details and Meter Station Meeting w/ DWC – September 27, 2024
- E. School District 204 Coordination Meeting for Bus Route Impacts – October 7, 2024
- F. ComEd Coordination Meetings – Various

V. Upcoming Tasks & Meetings

- A. ComEd Coordination Meetings – Various
- B. Phase II subsurface utility engineering (SUE) utility locating and potholing (ongoing).
- C. Phase II topographic surveying and field data collection along final route (ongoing).
- D. Phase II geotechnical field work (ongoing).
- E. Field data collection for cathodic protection design (ongoing).
- F. 75% Design Submittal – October 11, 2024.
- G. 90% Design Submittal – December 13, 2024.



Planning
Engineering
Program Management



**Cash Flow/Invoicing Forecast - Phase II Services
DuPage Water Commission
WaterLink Extension
October 2024**

Description	Activity through April 26, 2024	Activity through May 31, 2024	Activity through June 30, 2024	Activity through July 31, 2024	Activity through August 31, 2024	Activity through September 30, 2024	Planned	Planned	Planned	Planned	Planned	Planned	Planned	Planned	Planned	Planned	Planned
	May 2024	June 2024	July 2024	August 2024	September 2024	October 2024	November 2024	December 2024	January 2025	February 2025	March 2025	April 2025	May 2025	June 2025	July 2025	August 2025	September 2025
Basic Services	\$ 625,960	\$ 876,344	\$ 980,607	\$ 1,011,525	\$ 994,029	\$ 992,252	\$ 1,009,678	\$ 1,133,660	\$ 1,133,660	\$ 1,008,468	\$ 1,001,536	\$ 751,152	\$ 250,384	\$ 250,384	\$ 250,384	\$ 125,192	\$ 123,699
Additional Services	\$ 545,788	\$ 1,126,706	\$ 586,700	\$ 561,317	\$ 594,996	\$ 33,023	\$ 606,633	\$ 590,596	\$ 711,567	\$ 700,360	\$ 309,854	\$ 322,020	\$ 210,726	\$ 178,750	\$ 178,750	\$ 180,242	\$ -
MONTHLY SUBTOTAL	\$ 1,171,748	\$ 2,003,050	\$ 1,567,307	\$ 1,572,842	\$ 1,589,025	\$ 1,025,275	\$ 1,616,311	\$ 1,724,256	\$ 1,845,227	\$ 1,708,828	\$ 1,311,389	\$ 1,073,172	\$ 461,110	\$ 429,134	\$ 429,134	\$ 305,434	\$ 123,699
SUBTOTAL	\$6,314,947				\$5,954,868				\$7,687,129								
IGA ESCROW DEPOSITS	\$7,764,000				\$5,532,000				\$6,660,942								
TOTAL PHASE II CONTRACT															\$ 19,956,942		

**DuPage Water Commission
WaterLink Extension
Phase II Design Schedule**

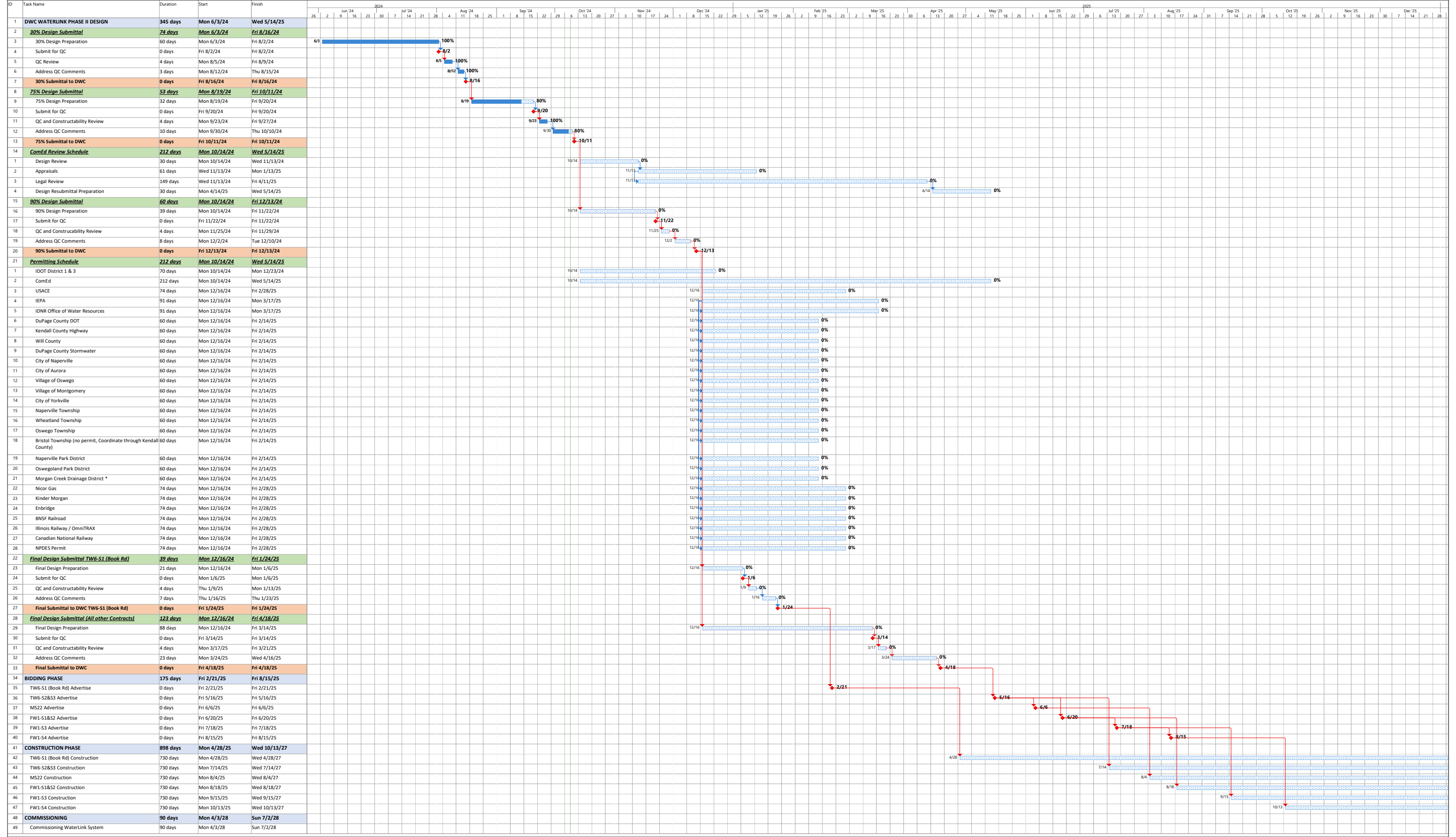

October 2024 Critical Task Task Progress



Resolution #: R-54-24

Account: 01-60-663100, \$30,000

Approvals: *Author / Manager / Finance / Admin*

D.P. RCB CAP PDM

REQUEST FOR BOARD ACTION

Date: 10/10/2024

Description: **A Resolution Approving Hydro-Vacuum Cleaning Services at a Cost Not to Exceed \$30,000**

Agenda Section: Engineering & Construction

Originating Department: Pipeline & Remote Facilities

As a function of the annual 2024 Air Release Structure Inspections, staff has identified twenty-four (24) manhole vault structures that require removal of debris from the bottom of the vaults. The proposed vault structure services include removal of debris by hydro-vacuum truck using pneumatic suction and pressurized water washing. Since each vault structure varies in depth and accumulated volume of debris requiring the removal, daily cost of service will be used as a payment unit.

In accordance with Commission Purchasing Procedures, staff solicited several proposals from Hydro-vacuum service providers and QR contractors to perform Hydro-vacuum cleaning services; three (3) proposals were received and are listed below:

Company	Daily Estimated Cost
Badger Daylighting Corp.	\$3,893.02
Rossi Contractors Inc.,	\$6,088.00
Benchmark Construction Co., Inc.	\$7,595.00
John Neri Construction Co., Inc.	Declined to submit

Staff recommends approval to procure the services of Badger Hydrovac Service to perform the Hydro-vacuum cleaning in the amount not to exceed cost of \$30,000.

Recommended Motion:

To approve R-54-24 for Hydro-Vacuum Services with Badger Daylighting Corp., in the amount not to exceed cost of \$30,000.

DuPAGE WATER COMMISSION

RESOLUTION NO. R-54-24

A RESOLUTION APPROVING PURCHASING HYDRO-VACUUM CLEANING SERVICES FROM
BADGER DAYLIGHTING CORP.

WHEREAS, pursuant to Article VIII, Section 4 of the Commission's By-Laws, and as required by State Statute, the Commission solicited proposals to provide Hydro-Vacuum Cleaning Services; and

WHEREAS, the Commission desires to clean Air Release basins; and

WHEREAS, staff solicited proposals in accordance with the Commission's Purchasing Procedures; and

WHEREAS, based upon representations made by staff, the Board of Commissioners of the DuPage Water Commission has determined that the proposal of Badger Hydrovac Service is most favorable to the interest of the Commission;

NOW, THEREFORE, BE IT RESOLVED by the Board of Commissioners of the DuPage Water Commission as follows:

SECTION ONE: The foregoing recitals are hereby incorporated herein and made a part hereof as findings of the Board of Commissioners of the DuPage Water Commission.

SECTION TWO The DuPage Water Commission hereby authorizes the purchase of Hydro-Vacuum Cleaning Services from Badger Daylighting Corp., for the price set forth in Its Proposal, not to exceed \$30,000.



Badger Hydrovac Service Proposal

United States

Prepared By:	Scott Schulz
Email:	SSchulz@badgerinc.com
Phone:	815-200-2064
Date:	10/01/2024
Estimate Number:	CPQ-113004v2
Project Name:	Dupage County Water Commission-Dupage County Vault Cleaning/revise



Badger Daylighting Corp
 MELROSE PARK IL CORP
 1740 N 25th Ave
 Melrose Park, IL 60160
 "An equal opportunity employer"

Estimate	
Date	10/01/2024
Reference	CPQ-113004
Prepared By	Scott Schulz

Customer Information			
Company	DUPAGE WATER COMMISSION	Contact Name	Bill Wegner
Contact Phone #	+1 (815) 474-2528	Email	wegner@dpwc.org
Billing Address	600 E BUTTERFIELD RD	Title	Operations
Billing City/State	Elmhurst IL 60126	Account Number	6509044
Service Address	Addison Rd & W Interstate Rd Addison IL 60101		

Scope Of Work

Customer has requested T&M rates for hydro-vac excavations services to clean out various vaults.

Service Item	Item Description	Unit Cost	UOM	Quantity	Amount
BADGER HYDROVAC WITH OPERATOR	Up to 8 Hrs. Port to Port/8 Hr. Min.	\$275.00	HR	8	\$2,200.00
BADGER HYDROVAC WITH OPERATOR OVERTIME	Over 8 Hrs. Port to Port/ Saturdays & Nights	\$325.00	HR	2.0	\$650.00
ADDITIONAL OPERATOR	UP TO 8 HOURS PORT TO PORT/8 HOUR MINIMUM	\$140.00	HR	0.0	\$0.00
ADDITIONAL OPERATOR OVERTIME	over 8 Hrs. port to port/ Saturdays & Nights	\$170.00	HR	0.0	\$0.00
DISPOSITION	If onsite disposal is not provided/Des Plaines Material	\$550.00	EA	0.0	\$0.00
CONSUMABLE MATERIALS		\$27.50	EA	1	\$27.50
SUPPLY WATER		\$82.50	EA	1	\$82.50
REMOTE HOSE	" Diameter	\$3.25	FT	0.0	\$0.00
SUPPORT TRUCK		\$165.00	DAY	0.0	\$0.00
FLUCTUATING FUEL RECOVERY		\$283.02	EA	1	\$283.02
DISPOSITION	If disposal onsite is not provided/Per Ton	\$130.00	TN	5.0	\$650.00

Total \$3,893.02



This proposal contains the budgetary estimate to complete the work as described above under the heading "Scope of Work". If any part of the work varies from that described in Scope of Work, or if unexpected digging conditions are encountered (eg rocks, rubble, roots, etc...), then additional charges shall apply. All work will be done on a time and material basis. All work will be done in accordance with the terms and conditions contained in Badger Daylighting Corp.'s standard terms and conditions (USA) attached hereto.

Customer (Company)	_____	PO #:	_____
Name (Please Print)	_____	Title:	_____
Signature	_____	Date:	_____

I am authorized to bind the Company



General Notes, Conditions, & Badger Responsibilities:

1. Travel rates apply when traveling from the closest Badger Operation to the client's project site.
2. Badger will off load material at contracted facility. Travel to and from a designated facility is considered part of the work day and charged at the hourly rate.
3. Any additional third party services provided by Badger Daylighting outside of our typical Hydrovac activities shall be charged out at cost +.
4. With any Hydrovac project, there are possible additional charges that are application and site specific. For example, items such as water trucks, specialized equipment and attachments (remote hose, etc.), crew trucks, and other items may be required. Rather than provide an extensive listing of all possible considerations, this is best implemented on a project-by-project basis and evaluated at the field operations level. The information presented in this document represents the complete proposal.
5. This proposal is valid for 30 days from the date posted on this proposal document.
6. Any and all quotes, offers and transactions are pending Credit Approval by Badger.
7. Terms of Payment - Net 30 days from date of invoice. Late invoices subject to service fees.
8. Zero (0) % retainage is withheld.
9. Taxes – tax will be added to quote pricing as required by State/Local governments.
10. All invoices will be assessed a Fluctuating Fuel Recover Fee on the entire amount of the invoice. This fee is reviewed regularly and is subject to change. Badger utilizes information from the US Department of Energy and the Canadian Department of Natural Resources when calculating the fee.

Customer responsibilities include:

1. Access to the Hydrovac site, including permits and permission from property owners, utilities, and government agents.
2. Surface locates, survey marks and traffic control, if needed unless agreed to in writing prior.
3. Breaking, removal, and restoration of asphalt and or concrete unless agreed to in writing prior.
4. Establish, maintain, and remediate accessible water source and disposal site.
5. Specific direction and locations for Hydrovac excavation.
6. Backfill and site restoration unless agreed to in writing prior to completing work.
7. Materials to secure and cover the excavation unless agreed to in writing prior.
8. Shoring, maintenance, and barricading.
9. Ownership of the soil and debris removed by the Hydrovac including any soils or material contaminated or suspect.
10. Any project delays caused by others that result in downtime of Badger Hydrovac units will be billed at the hourly rates.
11. Pay for all specialized training that is required by contractor/owner/Badger to be on the site to work.
12. Notify Badger of all billing requirements and any appropriate purchase orders, job numbers, AFE, etc. that would be necessary to release payment to Badger. This must be done prior to the first day of work.
13. Notify Badger of any of the following: Certified payrolls, OCIP requirements, prevailing wages.
14. Additional insurance requirements over what Badger already has in place

Customer Representative

Printed Name: _____

Signature: _____

Date: _____

I am authorized to bind the Company

Badger Representative

Printed Name: _____

Signature: _____

Date: _____



BADGER DAYLIGHTING CORP. STANDARD TERMS AND CONDITIONS (USA)

1. Definitions. "Service Provider" shall mean Badger Daylighting Corp. "Buyer" shall mean any party who contracts to purchase Services from Service Provider, as indicated on a service agreement or a statement of work. "Services" shall mean those services and any related goods ordered by Buyer from Service Provider pursuant to a service agreement accepted by Service Provider. "Credit Application" shall mean Service Provider's form of credit application, as may be amended from time to time, the review and written approval of which is a pre-requisite to Service Provider entering into any type of binding agreement with Buyer to provide Services. "USA" shall mean the United States of America.

2. Terms of Service Agreement Acceptance and Complete Agreement

(a) Acceptance. Buyer's order for Services is binding only when accepted in writing by an authorized representative of Service Provider, and is accepted subject to all of Service Provider's Standard Terms and Conditions of Services, which constitute the complete agreement between the parties. Buyer's acceptance of delivery and performance of Services evidences Buyer's acceptance of all of Service Provider's Standard Terms and Conditions of Services.

(b) No Acceptance. Service Provider's performance under any Buyer service agreement or a statement of work does not constitute an acceptance of any provision of any Buyer service agreement that is different from or additional to Service Provider's Standard Terms and Conditions of Services, and any such different or additional provisions are hereby expressly rejected and are void.

3. Buyer's Obligations.

(a) Services. Buyer shall: (i) cooperate with Service Provider in all matters relating to Services and provide such access to Buyer's premises, and other facilities as may reasonably be requested by Service Provider, for the purposes of performing Services; (ii) respond promptly to any Service Provider request to provide direction, information, approvals, authorizations or decisions that are reasonably necessary for Service Provider to perform Services in accordance with the requirements of the service agreement; (iii) provide such Buyer materials or information as Service Provider may reasonably request and Buyer considers reasonably necessary to carry out Services in a timely manner and ensure that such Buyer materials or information are complete and accurate in all material respects; and (iv) obtain and maintain all necessary permits and consents and comply with all applicable laws in relation to Services before the date on which Services are to start.

(b) Shipment and Delivery. Any goods provided in relation to the Services are sold EXW Service Provider's Facility Incoterms 2010. The method and route of shipment shall be as mutually agreed in each accepted service agreement. Service Provider shall tender delivery of all such related goods to a carrier for transportation to Buyer's place of business. All costs of transportation, including, without limitation, taxes and standard insurance shall be assessed by Service Provider and borne by Buyer unless otherwise agreed to in writing by Service Provider. Service Provider shall invoice Buyer for all shipping related costs.

All risk of loss shall pass to Buyer when such related goods are made available to the carrier at Service Provider's facility, including, without limitation, all risks of loading, transportation, and shipment. Delivery and acceptance shall not be affected by a delay on the part of Buyer in accepting delivery. Shipment of such related goods held by reason of Buyer's request or inability to receive such related goods will be at the risk and expense of Buyer. Claims for shortages in shipment shall be deemed waived by Buyer unless made in writing to Seller within thirty (30) days from the date of invoice.

4. Buyer's Acts or Omissions. If Service Provider's performance of its obligations under this Agreement is prevented or delayed by any act or omission of Buyer or its agents, subcontractors, consultants or employees, Service Provider shall not be deemed in breach of its obligations under the service agreement or otherwise liable for any costs, charges or losses sustained or incurred by Buyer, in each case, to the extent arising directly or indirectly from such prevention or delay. breach of its obligations under the service agreement or otherwise liable for any costs, charges or losses sustained or incurred by Buyer, in each case, to the extent arising directly or indirectly from such prevention or delay.

5. Taxes and Fees. Unless expressly stated and agreed to in writing by Service Provider, quoted prices do not include any shipping and handling charges, sales, use, excise, or similar taxes or duties. Buyer shall pay these taxes directly if the law permits or shall reimburse Service Provider if Service Provider is required to collect and pay them.

6. Representations and Warranties; Limitation of Remedy.

(a) Service Provider represents and warrants to Buyer that it shall perform Services using personnel of required skill, experience and qualifications and in a professional and workmanlike manner in accordance with generally recognized industry standards for similar services and shall devote adequate resources to meet its obligations under the service agreement.

(b) Service Provider shall not be liable to a breach of the warranty set forth in Section 6(a) unless Buyer gives written notice of the defective Services, reasonably described, to Service Provider with three (3) days of the time when Buyer discovers or ought to have discovered that Services were defective.

(c) The sole and exclusive remedy of Buyer for any liability of Service Provider of any kind, including (i) warranty, express or implied, whether contained in the terms and conditions hereof or in any terms additional or supplemental hereto, (ii) contract, (iii) negligence, (iv) tort, or (v) otherwise, is limited to Service Provider's repair or re-performance of Services. The sole and exclusive remedy for goods related to Services shall be Service Provider's repair or replacement of those related goods the examination of which by Service Provider reveals material defects during the warranty period or, at Service Provider's option, a refund to Buyer of the money paid to Services Provider for such goods. The warranty period shall begin on the date of completion of Services on Service Provider's invoice and shall continue for a period of one (1) year therefrom for all Services. This limited warranty shall not extend to any Services that have been modified, disassembled, altered, changed, damaged, misused, repaired, misapplied or negligently maintained in any manner.

(d) EXCEPT FOR THE EXPRESS LIMITED WARRANTY SET FORTH IN SECTION 6(a) ABOVE, SERVICE PROVIDER MAKES NO WARRANTY WHATSOEVER WITH RESPECT TO SERVICES, EXPRESS OR IMPLIED, INCLUDING ANY (i) WARRANTY OF MERCHANTABILITY; OR (ii) WARRANTY OF FITNESS FOR A PARTICULAR PURPOSE; OR (iii) WARRANTY OF TITLE; OR (iv) WARRANTY AGAINST INFRINGEMENT OF



INTELLECTUAL PROPERTY RIGHTS OF A THIRD PARTY; WHETHER EXPRESS OR IMPLIED BY LAW, COURSE OF DEALING, COURSE OF PERFORMANCE, USAGE OF TRADE OR OTHERWISE.

7. Limitation of Liability.

(a) SERVICE PROVIDER'S LIABILITY SHALL BE LIMITED TO THE COST OF REPAIR AND RE-PERFORMANCE OF SERVICES WITHIN A REASONABLE PERIOD OF TIME FOLLOWING PROPER AND TIMELY NOTICE BY BUYER. IN NO EVENT SHALL SERVICE PROVIDER BE LIABLE TO BUYER OR TO ANY THIRD PARTY FOR ANY LOSS OF USE, REVENUE, OR PROFIT; OR FOR ANY CONSEQUENTIAL, INCIDENTAL, INDIRECT, EXEMPLARY, SPECIAL OR PUNITIVE DAMAGES WHETHER ARISING OUT OF BREACH OF CONTRACT, TORT (INCLUDING NEGLIGENCE) OR OTHERWISE, REGARDLESS OF WHETHER SUCH DAMAGES WERE FORESEEABLE AND WHETHER OR NOT SERVICE PROVIDER HAS BEEN ADVISED OF THE POSSIBILITY OF SUCH DAMAGES, AND NOTWITHSTANDING THE FAILURE OF ANY AGREED OR OTHER ESSENTIAL PURPOSE. IN NO EVENT SHALL SERVICE PROVIDER'S AGGREGATE LIABILITY ARISING OUT OF OR RELATED TO THE SERVICE AGREEMENT, WHETHER ARISING OUT OF OR RELATED TO BREACH OF CONTRACT, TORT (INCLUDING NEGLIGENCE) OR OTHERWISE, EXCEED THE AGGREGATE AMOUNTS PAID OR PAYABLE TO SERVICE PROVIDER. Buyer agrees to indemnify and hold Service Provider harmless from and against all liabilities, claims, or demands of third parties of any kind relating to Services and the use of any related goods arising after performance of Services.

(b) The limitation of liability set forth in Section 7(a) above shall not apply to (i) liability resulting from Service Provider's gross negligence or willful misconduct and (ii) death or bodily injury resulting from Service Provider's negligent acts or omissions.

8. Rejection or Claims. A rejection of Services for non-conformity, or a claim of incomplete performance and/or damage by Buyer, shall not be effective unless it is made, and written notice thereof is given to Service Provider, within thirty (30) days after Services are provided to Buyer; or, with respect to any goods related to Services, within thirty (30) days after such related goods arrive at the destination specified in Service Provider's statement of work. Service Provider reserves the right to inspect the site of supposed non-conforming Services and to determine lack of conformity in its sole discretion.

9. Performance Dates. Service Provider shall use reasonable efforts to meet any performance dates specified in the service agreement, and any such dates shall be estimates only.

10. Failure to Take Delivery. If Buyer fails to take delivery of any goods related to Services, or any part thereof, such related goods not delivered shall be held at Buyer's sole risk in all respects. Service Provider, acting as Buyer's agent and at Buyer's expense, may thereafter store, insure and/or otherwise protect such related goods or may resell same for Buyer's account. The delivery date(s) quoted are based on Service Provider's best estimate of a realistic time when delivery to the carrier will be made, and are subject to confirmation at time of acceptance of any resulting Service Agreement. Service Provider reserves the right to make either early delivery or partial delivery upon prior notice to Buyer as provided in Section 23 hereof and to invoice Buyer accordingly.

11. Title and Risk of Loss or Damage. Title, risk of loss and/or damage shall pass to Buyer when any goods related to Services are made available to the carrier at Service Provider's facility.

12. Payment Terms.

All payments are due thirty (30) days from date of invoice in U.S. Dollars, unless otherwise specified by Service Provider. Buyer's failure to make payment when due will be a material breach of the service agreement and these Standard Terms and Conditions of Services. Subject to applicable law, amounts unpaid after such date may, at Service Provider's discretion, bear interest from the date of the invoice at a rate of one and one-half percent (1.5%) per month, or eighteen percent (18%) per annum. Service Provider shall be entitled to reimbursement from Buyer for all costs and fees, including reasonable attorneys' fees, incurred by Service Provider in the collection of any overdue amounts. Service Provider, at its sole option and without incurring any liability, may suspend its performance of Services until such time as any overdue payment is made or Service Provider receives assurances, adequate in Service Provider's opinion, that the payment will be promptly made. In the event of such suspension of performance of Services by Service Provider, there will be an equitable adjustment made to the remaining performance schedule and pricing to reflect the duration and cost resulting from such suspension. Buyer may only suspend performance upon Service Provider's written consent. In the event of such Buyer suspension, the performance time will be changed, taking into account the suspension, and Buyer will promptly pay Service Provider for all costs, including related overhead costs, resulting from such suspension. All terms of the Credit Application are incorporated into and are part of this Agreement.

For your convenience, Badger accepts payment in multiple forms including check, ACH, EFT, and certain credit cards. To the extent permitted by applicable law, payments made by credit card are subject to a surcharge equal to 3% of the transaction amount (or the highest percentage permitted by applicable law, if less than 3%).

13. Cancellation. Except as otherwise expressly provided in a statement of work, the service agreement shall be cancelled only by mutual written consent of the parties. Notice is hereby given that Service Provider shall not consent to cancellation if Buyer has bound itself to purchase Services. If Buyer is in default by failure to pay any previous invoice within credit terms at the expected date of performance of Services or any part thereof, has not otherwise performed or complied with any of the terms of the service agreement, in whole or in part; or becomes insolvent, files a petition for bankruptcy or commences or has commenced against it proceedings relating to bankruptcy, receivership, reorganization or assignment for the benefit of creditors, or if Service Provider has received any adverse credit information about Buyer, Service Provider may delay performance and/or cancel performance of Services without liability. In the event of U.S. or foreign government intervention, trade restrictions, and/or quotas, which may delay or prevent performance of Services or any part thereof, Service Provider, at Service Provider's option, may cancel the performance of Services without liability. In the event any Services shall become subject to any governmental fees or duties not presently in effect or to any increase in any existing fee or duty, including any antidumping duty or countervailing duty, Service Provider shall have the right to cancel performance of Services without liability.



14. **Default.** If Buyer breaches or is otherwise in default under the service agreement or under any other contract between the parties hereto, Service Provider at its sole option, may defer performance of Services until the default is cured, or may treat the default as a repudiation by Buyer of the service agreement in its entirety, and hold Buyer liable for such damages as Service Provider may incur, including consequential and incidental damages. For purposes hereof, Buyer's insolvency shall be a default.

15. **Waiver.** No waiver by Service Provider of any of the provisions of the service agreement is effective unless explicitly set forth in writing and signed by Service Provider. No failure to exercise, or delay in exercising, any rights, remedy, power or privilege arising from the service agreement operates or may be construed as a waiver thereof. No single or partial exercise of any right, remedy, power or privilege hereunder precludes any other or further exercise thereof or the exercise of any other right, remedy, power or privilege.

16. **Force Majeure.** Service Provider shall be free from any liability for delay or failure in performance of Services arising from strikes, lockouts, labor troubles of any kind, accidents, perils of the sea, fire, earthquake, civil commotion, terrorist acts, war or consequences of war, government acts, restrictions or requisitions, failure of manufacturers or suppliers to deliver, bankruptcy or insolvency of manufacturers or suppliers, suspension of shipping facilities, act or default of carrier or any other contingency of whatsoever nature beyond Service Provider's control affecting production and performance of Services, including disturbances existing on the date of the service agreement or a statement of work. In such a situation, if performance is not made during the period contracted for, Buyer shall accept performance under the service agreement when performance is made; provided, however, Buyer shall not be obligated to accept performance if performance is not made within a reasonable time after the cessation of the aforementioned impediments or causes.

17. **Intellectual Property.** All the designs, know-how, innovations, inventions and discoveries related to Services provided under this transaction shall be and remain the property of Service Provider.

18. **Confidential Information.**

(a) All non-public, confidential or proprietary information of Service Provider, including, but not limited to, trade secrets, technology, information pertaining to business operations and strategies, and information pertaining to customers, pricing, and marketing (collectively, the "Confidential Information"), disclosed by Service Provider to Buyer, whether disclosed orally or disclosed or accessed in written, electronic or other form or media, and whether or not marked, designated or otherwise identified as "confidential," in connection with the provision of Services and the service agreement is confidential, and shall not be disclosed or copied by Buyer without the prior written consent of Service Provider. Confidential Information does not include information that is (i) in the public domain; (ii) known to Buyer at the time of the disclosure; or (iii) rightfully obtained by Buyer on a non-confidential basis from a third party.

(b) Buyer agrees to use the Confidential Information only to make use of Services, and deliverables.

(c) Service Provider shall be entitled to injunctive relief for any violation of this Section.

19. **Integration.** The service agreement, these Standard Terms and Conditions of Services, and a statement of work supersede all prior negotiations, representations, agreements, quotes and catalogues, whether written or oral, and shall not be modified, supplemented or interpreted by evidence of course of dealing, course of performance or usage of trade. To the extent the provisions hereof conflict with any prior or subsequent agreement of the parties, these Standard Terms and Conditions of Services will control. Any amendment to these Standard Terms and Conditions of Services must be in writing and signed by both parties.

20. **Assignment.** Buyer acknowledges that no service agreement or statement of work, nor the obligations represented thereby, may be assigned or delegated, in whole or in part by Buyer, without the prior written consent of Service Provider. Buyer's unauthorized attempt to assign or delegate any rights or obligations shall serve as grounds for termination of the service agreement.

21. **Severability.** Service Provider and Buyer agree that each and every paragraph, sentence, clause, term and provision of these Standard Terms and Conditions of Services is severable and that, in the event any portion hereof is adjudged to be invalid or unenforceable, the remaining portions shall remain in full force and effect to the fullest extent permitted by law.

22. **Relationship of the Parties.** The relationship between the parties is that of independent contractors. Nothing contained in these Standard Terms and Conditions of Services or the service agreement shall be construed as creating any agency, partnership, joint venture or other form of joint enterprise, employment or fiduciary relationship between the parties; and neither party shall have authority to contract for or bind the other party in any manner whatsoever.

23. **Notices.** All notices, requests, consents, claims, demands, waivers and other communications hereunder (each, a "Notice") shall be in writing and addressed to the parties at the addresses set forth in the service agreement or to such other address that may be designated by the receiving party in writing. All Notices shall be delivered by personal delivery, nationally recognized overnight courier (with all fees prepaid), facsimile (with confirmation of transmission) or certified or registered mail (in each case, return receipt requested, postage prepaid). Except as otherwise provided in the service agreement, a Notice is effective only (a) upon receipt of the receiving party, and (b) if the party giving the Notice has complied with the requirements of this Section.

24. **Governing Law; Venue.** All matters involving the validity, interpretation and application of these Standard Terms and Conditions of Services will be controlled by the laws of the State of Indiana, United States of America and Buyer and Service Provider hereby irrevocably consent to the jurisdiction of the state and federal courts located in Marion County, Indiana for the resolution of any disputes arising under these Standard Terms and Conditions of Services and the service agreement.

25. **Collection, Use and Disclosure of Information.**



Notwithstanding section 18, by submitting an application for the Services, Buyer consents to and authorizes Service Provider and its service providers to use the personal information, confidential information, financial information and other details (collectively "Information") about Buyer that Buyer has provided to:

- (a) Exchange Information and reports about Buyer with credit reporting agencies, credit reporting services including Creditsafe USA Inc., and other lenders (collectively "Credit Agencies") prior to the commencement of Services for the purposes of Service Provider providing credit to Buyer, including in the form of an outstanding receivable with the Service Provider for Services to be performed pursuant to these Service Provider's Standard Terms and Conditions of Services;
- (b) Conduct, or arrange for a Credit Agency to conduct, "soft" or "hard" credit checks from time to time for up to one year after Buyer submits an application and Service Provider exchanges Information with Credit Agencies;
- (c) Conduct, or arrange for third parties to conduct, risk assessments and identity and payment verification checks from time to time;
- (d) Assess Buyer's application for the Services based on the results of the credit, risk assessment, and identity and payment verification checks;
- (e) Periodically review and verify Buyer creditworthiness, establish credit and hold limits, help Service Provider collect a debt or enforce an obligation owed to Service Provider by Buyer, and/or manage and assess risk; and
- (f) Issue a decision to grant or deny Buyer's application for credit.

Service Provider shall determine in its sole discretion whether to grant any credit to Buyer and, if so, the amount of any such credit. Service Provider has no obligation to grant any credit, and any granting of credit is without commitment to provide any future credit. Buyer shall be responsible for all credit it receives from Service Provider, whether or not such credit exceeds authorized credit limits. In the event that Service Provider grants credit to Buyer and for a reasonable period of time afterwards, Service Provider may from time to time disclose Buyer's Information to other lenders and credit reporting agencies requesting such Information. Service Provider may obtain Information and reports about Buyer from third party providers such as Creditsafe USA Inc., and other Credit Agencies. Once Buyer has applied for credit with Service Provider, Buyer may not withdraw their consent to this exchange of Information.

For more information about the Service Provider's privacy policy and our collection and use of personal information, please see: [https://www.badgerinc.com/learn-about-badger/privacy\[1\]antispam-web-policy/](https://www.badgerinc.com/learn-about-badger/privacy[1]antispam-web-policy/).

End



T&M rates for hydro-vac excavations services to clean out various vaults.

Service Item	Item Description	Unit Cost	UOM	Quantity	Amount
HYDROVAC WITH 2 Laborers	Up to 8 Hrs. Port to Port/8 Hr. Min.	\$450	HR	8	\$3600
HYDROVAC WITH 2 Laborer OVERTIME	Over 8 Hrs. Port to Port/ Saturdays & Nights	\$550	HR	2	\$1100
ADDITIONAL Laborer (IF NEEDED ONLY)	Up to 8 Hrs. Port to Port/8 Hr. Min.	\$130	HR	8	\$1040
ADDITIONAL Laborer OVERTIME (IF NEEDED ONLY)	over 8 Hrs. port to port/ Saturdays & Nights	\$170	HR	2	\$340
SUPPORT TRUCK (IF NEEDED ONLY)		\$80	HR	8	\$640
DISPOSAL		\$175	TN	5	\$875

Total **\$7,595**

From: Nicholas.Neri@johnnericonstruction.com
To: [Dariusz Panaszek](#)
Cc: [Nick Neri](#)
Subject: RE: Hydro cleaning of various vault structures
Date: Thursday, September 26, 2024 10:22:42 AM

Dariusz,

Thank you for the opportunity, however, we do not self-perform any of this work so we would have to sub it out to another company which would just incur higher costs to the DPWC. We appreciate your thought and look forward to the next opportunity to work for the DPWC.

Thank you,

Nicholas N. Neri
John Neri Construction Co.
770 Factory Road, Addison, IL 60101
P(630)-629-8384; F(630)-629-7001
www.johnnericonstruction.com

From: Dariusz Panaszek <panaszek@dpwc.org>
Sent: Monday, September 23, 2024 2:27 PM
To: Taylor Heppeler <theppeler@rossicontractors.com>; Nicholas.Neri@johnnericonstruction.com; Nick Neri <Nneri@johnnericonstruction.com>; matkinsjr@bmk8.com; dominickf@bmk8.com
Cc: Bill Wegner <wegner@dpwc.org>
Subject: Hydro cleaning of various vault structures

CAUTION: This email originated from outside your organization. Exercise caution when opening attachments or clicking links, especially from unknown senders.

DWC is in need to clean out, using hydro vac method, some road debris in manhole vaults at the various locations. There is approx. 2 cu. ft. of debris accumulated at the bottom of the vault. Would you be able to provide a per-day estimate for a requested service. Please include disposal of vacuumed material as a part of your quote. DWC tech will escort the contractor to each discrete site. Based on prior experience performing similar work, we will need about 5-6 days to complete this task.

This e-mail and any of its attachments may contain confidential information belonging or pertaining to the DuPage Water Commission. This e-mail is intended solely for the use of the individual or entity to which it is addressed. If you are not the intended recipient of this e-mail, you are hereby notified that any dissemination, distribution, copying, or action taken in relation to the contents of and attachments to this e-mail is strictly prohibited and may be unlawful. If you have received this e-mail in error, please notify

the sender immediately and permanently delete the original and any copy of this e-mail and any printout. Thank You.

T&M rates for hydro-vac excavations services to clean out various vaults.

Service Item	Item Description	Unit Cost	UOM	Quantity	Amount
HYDROVAC WITH OPERATOR	Up to 8 Hrs. Port to Port/8 Hr. Min.	\$448	HR	8	\$3,584.00
HYDROVAC WITH OPERATOR OVERTIME	Over 8 Hrs. Port to Port/ Saturdays & Nights	\$518.50	HR	2	\$1,037.00
ADDITIONAL OPERATOR (IF NEEDED ONLY)	Up to 8 Hrs. Port to Port/8 Hr. Min.	-	HR	8	-
ADDITIONAL OPERATOR OVERTIME (IF NEEDED ONLY)	over 8 Hrs. port to port/ Saturdays & Nights	-	HR	2	-
CONSUMABLE MATERIALS		-	EA	1	-
SUPPLY WATER		\$27.00	EA	1	\$27.00
SUPPORT TRUCK (8 hrs.)		\$1,170.00	EA	1	\$1,170.00
		-	EA		-
DISPOSAL		\$54.00	TN	5	\$270.00

Total: \$6,088.00



Resolution #: R-56-24

Account: 01-60-771700 \$31,122

Approvals: Author / Manager / Finance / Admin

DC RCB CAP PDM

REQUEST FOR BOARD ACTION

Date: 10/10/2024

Description: **A Resolution Approving and Ratifying Change Orders to a Contract for the SCADA Replacement Project (Contract PSD-9/21)**

Agenda Section: Engineering & Construction

Originating Department: Systems & Information Technology

Resolution No. R-56-24 would approve the following Change Orders (*Contract Price Increase of \$31,122.00*):

Change Order No. 5 to Contract for the SCADA Replacement Project (Contract PSD-9/21)

1. Purchase of UPS Surge Protection Devices. (Addition of \$7,520.00)
2. An accumulation of miscellaneous changes to labor and hardware through Concentric. (Addition of \$23,602.00)

Approval of this Change Order would increase the net Contract Price by \$31,122.00, revising the Contract Price from \$15,546,598.83 to \$15,577,720.83 for a 0.2% net total increase from the Contract Price.

Approval of this Change Order does not authorize or necessitate a decrease in the Contract Price that is 50% or more of the original Contract Price nor, based upon the Contractor's sworn certification, authorize or necessitate an increase in the price of any subcontract under the Contract that is 50% or more of the original subcontract price.

Recommended Motion:

To Adopt Resolution R-56-24

DUPAGE WATER COMMISSION

RESOLUTION NO. R-56-24

A RESOLUTION APPROVING AND RATIFYING
CERTAIN CHANGE ORDERS TO A CONTRACT FOR THE
SCADA REPLACEMENT PROJECT (CONTRACT PSD-9/21)

BE IT RESOLVED by the Board of Commissioners of the DuPage Water Commission as follows:

SECTION ONE: The Change Orders set forth on Exhibit 1, attached hereto and by this reference incorporated herein and made a part hereof, shall be and hereby are approved and, if already issued, ratified because the Board of Commissioners of the DuPage Water Commission has determined, based upon the representations of staff and the contractors, that the circumstances said to necessitate the changes were not reasonably foreseeable at the time the contracts were signed, the Change Orders are germane to the original contracts as signed and/or the Change Orders are in the best interest of the DuPage Water Commission and authorized by law.

SECTION TWO: This Resolution shall constitute the written determination required by Section 33E-9 of Article 33E of the Criminal Code of 1961 and shall be in full force and effect from and after its adoption.

SECTION THREE: This Resolution shall be in full force and effect from and after its adoption.

	Aye	Nay	Absent	Abstain
Bouckaert, D.				
Cuzzone, N.				
Fennell, J.				
VACANT	_____			
Novotny, D.				
Pruyn, J.				
Romano, K.				
Rush, K.				
Russo, D.				
Saverino, F.				
Suess, P.				
Van Vooren, D.				
Zay, J.				

ADOPTED THIS ____ DAY OF _____, 2024.

James F. Zay, Chairman

ATTEST:

Danna Mundall, Clerk

Board/Resolutions/2024/R-56-24.docx

EXHIBIT 1

DELETE PAGE IF NO ATTACHMENT

DuPAGE WATER COMMISSION
CHANGE ORDER

SHEET 1 OF 3

PROJECT NAME: SCADA Replacement Project
LOCATION: Cook and DuPage Counties, Illinois
CONTRACTOR: Baxter & Woodman/Boller Construction

CHANGE ORDER NO. 5
CONTRACT NO. PSD-9/21
DATE: October 9, 2024

I. A. DESCRIPTION OF CHANGES INVOLVED:

1. Purchase of new UPS Surge Protection Devices
2. An accumulation of miscellaneous changes to labor and hardware through Concentric

B. REASON FOR CHANGE:

1. During the installation of the DPPS UPS system it was determined that there was a discrepancy between the design drawings and the panels the system feeds. The subpanels fed by the UPS system were shown as three phase panels when they are single phase panels. The surge protection devices originally purchased are for three phase panels, so a change was requested to purchase and install the appropriate single phase surge protection devices for an additional cost of \$7,520.00 for labor and materials.
2. Throughout the integration of the new SCADA system, Commission staff and Concentric staff have made minor modifications to both labor and materials that have been tracked and are being formalized in the list below:
 - a. Purchase and installation of an additional stack light and a total of 51 blinking stack light modules.
 - b. Modification of PLC programming, wiring schematics, and documentation due to tag naming modifications.
 - c. Credit for labor not used with the temporary office relocation.
 - d. Credit for BAS development not required.
 - e. Credit for desktop UPS units not purchased.
 - f. Credit for flow switch not required.
 - g. Purchase and installation of 10 relays required for normally closed contact modification for run feedback signals.
 - h. Purchase and installation of 10 relays required for modification to Local/Remote switches.
 - i. Purchase and installation of three (3) new rack mounted UPS units for the radio/cellular backhaul equipment.

- j. Additional labor cost for the A/V system installation and testing due to downtime and delays caused by power issues.
- k. Additional labor and modification to the Backup Telemetry System flow totalization and screen development.

These modifications in labor and hardware come at an additional cost of \$23,602.00.

C. REVISION IN CONTRACT PRICE:

1.	Purchase of new UPS Surge Protection Devices	\$7,520.00
2.	An accumulation of miscellaneous changes to labor and hardware through Concentric	\$23,602.00
3.	Total Change in Contract Price This Change Order	<u><u>\$31,122.00</u></u>

II. CHANGE ORDER CONDITIONS:

- 1. The Completion Date established in the Contract, as signed or as modified by previous Change Orders, maintains the final Completion Date of May 31, 2026.
- 2. Any Increased Work to be performed under this Change Order shall be provided, performed, and completed in full compliance with, and as required by or pursuant to, the Contract, including any Specifications and Contract Drawings for the Increased Work and for Work of the same type as the Increased Work, and as specified in the preceding "Description of Changes Involved."
- 3. Unless otherwise provided herein, all Work included in this Change Order shall be guaranteed and warranted as set forth in, and Contractor shall not be relieved from strict compliance with, the guaranty and warranty provisions of the Contract.
- 4. All Work included in this Change Order shall be covered under the Bonds and the Required Coverages specified in the Contract. If the Contract Price, including this Change Order, exceeds the Contract Price set forth in the Contract, as signed, by twenty percent (20%), Contractor shall submit to Owner satisfactory evidence of such increased coverage under the Bonds if requested by Owner.

III. ADJUSTMENTS IN CONTRACT PRICE:

1.	Original Contract Price	\$ <u>16,443,000.00</u>
2.	Net reduction due to all previous Change Orders Nos. <u>1</u> to <u>4</u>	\$ <u>-896,401.17</u>
3.	Contract Price, not including this Change Order	\$ <u>15,546,598.83</u>
4.	Increase to Contract Price due to this Change Order	\$ <u>31,122.00</u>
5.	Contract Price including this Change Order	\$ <u>15,577,720.83</u>

RECOMMENDED FOR ACCEPTANCE:

CONSULTING ENGINEERS: Carollo Engineers

By: _____ ()
Signature of Authorized Representative Date

ACCEPTED: By my authorized signature below, being first duly sworn on oath, I certify on behalf of Contractor that this Change Order does not authorize or necessitate an increase in the price of any Subcontract under the Contract that is 50% or more of the original Subcontract price.

CONTRACTOR: Baxter & Woodman/Boller Construction, LLC

By: _____ ()
Signature of Authorized Representative Date

DUPAGE WATER COMMISSION:

By: _____ ()
Signature of Authorized Representative Date



MEMORANDUM

To: Paul May, General Manager
From: Cheryl Peterson, Financial Administrator
Date: 10/8/2024
Subject: Accounts Payable Listings

Following is a summary of the Accounts Payable to be considered at the October 17, 2024, Commission meeting:

September 11, 2024, to October 8, 2024, A/P Report	\$12,744,098.00
Accrued and estimated payments required before November 2024 Commission meeting	<u>2,488,875.00</u>
Total	<u><u>\$15,232,973.00</u></u>

cc: Chairman and Commissioners



Payable Number	Description	Post Date	Payable Amount	Payable Count	Net Amount
Payable Account: 01-211000 - ACCOUNTS PAYABLE					
Vendor: 2464	A.K. MULCH & FIREWOOD			Payable Count: (2)	449.00
INV0007841	Stone for Drainage Project	09/30/2024	124.00		124.00
INV0007846	Materials for Site Drainage Project	10/08/2024	325.00		325.00
Vendor: 2447	Accenture LLP			Payable Count: (1)	11,100.00
1101026275	Quarterly Support (September - December 2024)	09/30/2024	11,100.00		11,100.00
Vendor: 1663	AECOM			Payable Count: (1)	1,534.62
2000933185	Tollway Review	09/19/2024	1,534.62		1,534.62
Vendor: 2228	Aitorfer Industries, Inc.			Payable Count: (1)	531.95
PM6A0030214	Inspection for Generator Repair	09/30/2024	531.95		531.95
Vendor: 1306	AMWA			Payable Count: (1)	8,600.00
12312025	Partial Dues (January 1 - December 31, 2025)	10/01/2024	8,600.00		8,600.00
Vendor: 2283	BMO HARRIS CREDIT CARD			Payable Count: (1)	4,214.88
INV0007842	Combined Statements: September 2024	09/30/2024	4,214.88		4,214.88
Vendor: 2523	CBIZ Valuation Group, LLC			Payable Count: (1)	16,000.00
1112069310	Property Insurance Valuation Client No. 549766	09/30/2024	16,000.00		16,000.00
Vendor: 1023	CDW Government			Payable Count: (1)	12.91
AA8BA4N	Car Charger	09/30/2024	12.91		12.91
Vendor: 1964	CHRISTOPHER B. BURKE ENGINEERING, LTD.			Payable Count: (3)	89,688.05
194784	Green Acres Site Plan	09/17/2024	20,023.46		20,023.46
195321	Professional Services	09/19/2024	5,775.00		5,775.00
195640	Professional Services	09/30/2024	63,889.59		63,889.59
Vendor: 1135	CITY OF CHICAGO SUPERINTENDENT OF WATER COLLECTION			Payable Count: (1)	12,522,065.40
INV0007843	WATER BILLING: September 2024	09/30/2024	12,522,065.40		12,522,065.40
Vendor: 2321	Concentric Integration, LLC			Payable Count: (1)	2,947.50
0263958	SQL Support & Meter Shop Backup Plan Development	09/30/2024	2,947.50		2,947.50
Vendor: 2258	CRAMER MARKETING			Payable Count: (1)	177.43
44806	Tax Forms	09/30/2024	177.43		177.43
Vendor: 1096	Environmental Systems Research Institute, Inc.			Payable Count: (1)	11,300.00
94812072	GIS Software Annual Maintenance Fee	10/08/2024	11,300.00		11,300.00
Vendor: 2171	Friendly Ford			Payable Count: (1)	801.68
123616	Vehicle Repairs: M223625	09/19/2024	801.68		801.68
Vendor: 1064	GOVERNMENT FINANCE OFFICERS ASSOCIATION			Payable Count: (1)	160.00
2436001	Membership Renewal: 11/1/24-10/31/25	10/08/2024	160.00		160.00
Vendor: 1429	GRAYBAR			Payable Count: (1)	128.88
9339048118	Parts for ROV 10C	09/30/2024	128.88		128.88
Vendor: 2501	Haeger Engineering			Payable Count: (1)	2,770.00
93512	Professional Services: 75th Street Parcel	09/17/2024	2,770.00		2,770.00
Vendor: 1609	Illinois GIS Association			Payable Count: (1)	85.00
2443	Annual Membership	09/17/2024	85.00		85.00
Vendor: 1063	ILLINOIS SECTION AWWA			Payable Count: (2)	1,582.00
200089631	IEPA Class C/D - Van Meter	09/24/2024	791.00		791.00

Board Open Payable Report

As Of 10/08/2024

Payable Number	Description	Post Date	Payable Amount	Net Amount
200089676	IEPA Class C/D - Lithas	09/24/2024	791.00	791.00
Vendor: 1530 SIR009933	IRTH SOLUTIONS, INC. Annual User Fee: 10/1/24-9/30/25	10/01/2024	22,732.68	Payable Count: (1) 22,732.68
Vendor: 1033 0354233F24	JOLIET JUNIOR COLLEGE Electrical Safety Classes for Employees	09/19/2024	8,432.00	Payable Count: (1) 8,432.00
Vendor: 2379 96018534	Komatsu Forklift USA, LLC Scrubber Maintenance Check	09/30/2024	222.00	Payable Count: (1) 222.00
Vendor: 1054 34345346	MCMMASTER-CARR SUPPLY COMPANY Motor Replacement Supplies	10/08/2024	103.86	Payable Count: (1) 103.86
Vendor: 2198 51909 51913	Mecon Industries, Inc. Unloading of new cone valve Service Call: Repair/Insulation of Roof Drain Leak	09/24/2024 09/30/2024	2,478.08 7,309.00	Payable Count: (2) 2,478.08 7,309.00
Vendor: 1194 SC0000077648	MK BATTERY Batteries - Return for Recycling	03/26/2024	-864.00	Payable Count: (1) -864.00
Vendor: 2189 INV0007781 INV0007805	NCPERS Group Life Ins. NCPERS - IMRF 6641 NCPERS - IMRF 6641	09/13/2024 09/27/2024	44.28 44.28	Payable Count: (2) 44.28 44.28
Vendor: 2227 11373876	Nilfisk Annual Floor Scrubber Service	09/30/2024	265.00	Payable Count: (1) 265.00
Vendor: 1321 PER-IN-103307	PERSPECTIVES, LTD. EMPLOYEE ASSISTANCE SVC: QUARTER 4 2024	10/03/2024	273.00	Payable Count: (1) 273.00
Vendor: 1642 12870518-00 12874181-00	PORTER PIPE & SUPPLY CO. Meter Station Supplies Pipe Supplies	09/30/2024 10/08/2024	857.56 80.59	Payable Count: (2) 857.56 80.59
Vendor: 1385 32578	QUALITY BACKFLOW TESTING INC. Backflow Leak Repair	09/24/2024	1,350.00	Payable Count: (1) 1,350.00
Vendor: 1730 511316	RAILROAD MANAGEMENT COMPANY III, LLC License Fees: (1/10/25-1/9/26)	10/01/2024	417.05	Payable Count: (1) 417.05
Vendor: 2473 DUPAGEWC09302024	Reliable High Performance Products, Inc. Uniforms	09/30/2024	2,503.31	Payable Count: (1) 2,503.31
Vendor: 1813 FOCS214544	ROESCH FORD Vehicle Maintenance: M228277	10/08/2024	233.59	Payable Count: (1) 233.59
Vendor: 2156 SPI20816731	Russo Power Equipment Pole Pruner	09/26/2024	659.62	Payable Count: (1) 659.62
Vendor: 2181 24-009-4906	Second Chance Cardiac Solutions, Inc. AEDs and Supplies	09/30/2024	5,516.85	Payable Count: (1) 5,516.85
Vendor: 1263 280539	SKARSHAUG TESTING LABORATORY, INC. Electrical Glove and Boot Testing	09/26/2024	495.68	Payable Count: (1) 495.68
Vendor: 1223 228685	SUBURBAN LABORATORIES, INC. UCMR & Aluminum Testing	09/30/2024	590.50	Payable Count: (1) 590.50
Vendor: 2519 3187	Tai Ginsberg & Associates, LLC Retainer: Strategic Funding & Advocacy Consulting	09/17/2024	9,500.00	Payable Count: (1) 9,500.00
Vendor: 1404 3136	VIKING AWARDS, INC. Retirement Plaque	09/17/2024	137.10	Payable Count: (1) 137.10
Vendor: 1887 940291516	WEG ELECTRIC CORP. Parts for Highlift Motor Sync Wheel	09/30/2024	4,900.00	Payable Count: (1) 4,900.00

Board Open Payable Report

As Of 10/08/2024

Payable Number	Description	Post Date	Payable Amount		Net Amount
Vendor: 2096	William A. Fates			Payable Count: (1)	1,666.67
INV0007822	Service as Treasurer: October 2024	10/03/2024	1,666.67		1,666.67
			Payable Account 01-211000	Payable Count: (48) Total:	12,744,098.00

Payable Account Summary

Account	Count	Amount
01-211000 - ACCOUNTS PAYABLE	48	12,744,098.00
Report Total:	48	12,744,098.00

Payable Fund Summary

Fund	Count	Amount
01 - WATER FUND	48	12,744,098.00
Report Total:	48	12,744,098.00

DUPAGE WATER COMMISSION
ITEMS TO BE PAID BY 11-21-24
Board Meeting Date: October 17, 2024

Estimate Amount	Description	Check Number	Payment Date	Payment Amount
70,000.00	Blue Cross Blue Shield - Health Insurance			
8,500.00	Euclid Managers - Dental Insurance			
12,000.00	Illinois Public Risk Fund - Workers Comp.			
200.00	Envision Health Care - Administration Fees			
400.00	Healthiest You			
150.00	NCPERS - IMRF			
25,000.00	ComEd - Utility Charges			
400,000.00	Mid American Energy Services - Utility Charges			
180,000.00	City of Chicago - Lexington, Electric			
45,000.00	City of Chicago - Lexington Labor Costs			
35,000.00	City of Chicago - Repairs & Maintenance			
2,000.00	City of Naperville -Meter Station Electric Bills			
15,000.00	Nicor - Gas			
400.00	Comcast - Internet Service			
3,000.00	AT & T - Telephone Charges			
3,000.00	AT & T - Scada Backhaul Network/IP Flex			
1,000.00	Fed - Ex - Postage/Delivery			
2,400.00	Procurement Card Charges - Training \$1000, Conferences: \$2200 Admin \$50, Project Supplies \$800, Subscriptions \$200 Vehicles \$200			
200.00	Anderson - Pest Control			
500.00	Republic Services - Disposal Services			
500.00	Aramark - Supplies			
1,000.00	Cintas- Supplies			
200.00	Elecsys - Cell Data Services			
3,500.00	AL Warren - Fuel			
600.00	Toshiba - Copy and Lease Charges			
2,500.00	Multisystem Management - Cleaning Services			
625.00	Pitney Bowes - Postage			
8,000.00	Grainier - Supplies for Operations			
2,500.00	Verizon - Wireless Service			
500.00	Verizon Connect - Diagnostics			
50.00	City of Aurora - Microbial Analysis			
150.00	Logical Media - Hosting Services			
1,700.00	William Fates - Treasurer			
6,000.00	Baker Tilly			
45,000.00	Schirott, Luetkehans & Garner, LLC			
8,000.00	Schirott, Luetkehans & Garner, LLC - MOY			
7,000.00	IT Savvy - Network Support			
200.00	Alexander Kefaloukos - Security			
600.00	Red Wing - Uniforms			
100.00	Elmhurst Occupational Health - New employee			
500.00	Elmhurst Standard Plaza - Vehicle Maintenance			
200.00	Soooper Lube - Vehicle Maintenance			
200.00	Sterling - Background Checks			
5,000.00	Storino Ramello & Durkin			
500.00	Local 399 Training courses			
125,000.00	Altorfer - Generator Facility Switchgear Battery Replacement & Spare Parts			
6,000.00	Altorfer - Generator Gas Line Regulator Repair			
1,000.00	American Society of Engineers - Job Posting			
300.00	Batteries Plus - Batteries			
30,000.00	Beary - Landscaping (Northbrook)			
4,000.00	Beary - Landscaping			
2,000.00	Beary - Tanksite Landscaping			
2,000.00	Bedrock - Landscaping			
400.00	CDW - Wireless Keyboard and Mouse			
11,000.00	Core & Main - Surge Relief Kits			
3,000.00	Corrosion Protection - Temperature Sensor Replacement			
500.00	Ebef's Ace Hardware - Project Supplies			
300.00	Friendly Ford - Vehicle Maint			
7,500.00	Grainier - New/Replacement Body Harnesses			
12,000.00	Grainier - Sump Pumps for ROV's & MS			
200.00	Graybar - Pipeline Supplies			
20,000.00	HazChem - Diesel Spill, Ground Water Monitoring, Well Closure, Reporting			
500.00	Home Depot - Project Supplies			
2,000.00	Home Depot - Pipeline Supplies			

**DUPAGE WATER COMMISSION
ITEMS TO BE PAID BY 11-21-24
Board Meeting Date: October 17, 2024**

4,000.00	HSQ - Power Control Boards
3,000.00	Jude Vickery - Temperature Sensor Installation
300.00	IL American Public Works Assoc - Membership Dues
400.00	IL American Public Works Assoc - Job Posting
100.00	IL City/County Management Assoc - Job Posting
1,000.00	Indeed - Job Posting
100.00	IL Municipal League - Job Posting
3,000.00	Meccon - Repair Supply Valve Line
15,000.00	Meccon - Rebuild influent and effluent valves
4,500.00	MESA - Replenish Reference Cells/Feasibility Study
1,100.00	MK Battery - Battery Replacement for TS Radio/Security Panels
600.00	National Society of Professional Engineers - Job Posting
300.00	Office Depot - Supplies
200.00	Project Management Institute - Membership Renewal
1,000.00	Program One - Window Cleaning
5,700.00	Regional Truck - Vehicle Lighting/Improvements
5,000.00	Reliable - Uniforms
300.00	RedWing - Safety Shoes Constantopoulos
11,000.00	Safety Training Plus - Regulatory Training April 2025
400.00	Specialty Mat - Rags
1,000.00	Specialty Mat - Mat Service
1,000.00	SPI - Consulting Services
700.00	Staples - Office Supplies
4,000.00	Suburban Laboratories - UCMR & Aluminum Testing
1,000.00	Thytrionics - Repair Multilin SR469 removed from HLP #3
2,500.00	Weg - Spare Parts for Highlift Motor Sync Wheel
25,000.00	Weg - Repair and parts for Highlift Motor Sync Wheel
400,000.00	Baxter & Woodman/Boller Construction - SCADA
20,000.00	Carollo - SCADA
40,000.00	Strand - SCADA
5,000.00	HSQ - Spare Parts
5,000.00	SPI Energy Group - Consulting Services
10,000.00	Donohue Engineering - Consulting Services
45,000.00	Benchmark QR 12/21 WAO 28
5,000.00	Gallagher - Treasurer Bond
740,000.00	AJ Gallagher - Property/Liability Insurance
100.00	City of Chicago - Water Billing
<hr/>	
2,488,875.00	



MEMORANDUM

To: Commissioners

From: Paul D. May, P.E., General Manager

Date: October 10, 2024

Subject: Luetkehans, Brady, Garner & Armstrong July 2024 Invoices

I reviewed the Luetkehans, Brady, Garner & Armstrong invoices for services rendered during the period of August 1, 2024 through August 31, 2024 and recommend it for approval. The invoices should be placed on the October 17, 2024 Commission meeting accounts payable.

August 2024

Luetkehans Brady Garner & Armstrong

<u>CATEGORY</u>	<u>FEES</u>	<u>HOURS BILLED</u>	<u>AVERAGE HOURLY RATE</u>	<u>ATTORNEYS & PARALEGALS EMPLOYED</u>	<u>MAJOR ACTIVITIES</u>
General	\$2,009.00	8.20	\$245.00	Luetkehans (6.20 @ \$245/hr.) Armstrong (0.20@245/hr.) Padilla (1.80 @ \$245/hr.)	various (meetings, review agreements, correspondence, contracts, telephone conferences, and attend Board meeting)
Misc:	\$114.17				
Total:	\$2,123.17	8.20	\$0.00		

<u>CATEGORY</u>	<u>FEES</u>	<u>HOURS BILLED</u>	<u>AVERAGE HOURLY RATE</u>	<u>ATTORNEYS & PARALEGALS EMPLOYED</u>	<u>MAJOR ACTIVITIES</u>
Chicago Contract	\$318.50	1.30	\$245.00	Luetkehans (1.30 @ \$245/hr.)	various (meetings, review agreements, correspondence, contracts, telephone conferences, and attend Board meeting)
Misc:	\$ -				
Misc: Georges & Synowiecki Statement #24	\$ 490.00				
Total:	\$808.50	1.30	\$245.00		

<u>CATEGORY</u>	<u>FEES</u>	<u>HOURS BILLED</u>	<u>AVERAGE HOURLY RATE</u>	<u>ATTORNEYS & PARALEGALS EMPLOYED</u>	<u>MAJOR ACTIVITIES</u>
Source Water	\$3,969.00	16.20	\$245.00	Luetkehans (9.40 @ \$245/hr.) Armstrong (6.80 @ \$245/hr.)	various (meetings, review agreements, correspondence, contracts, telephone conferences, and attend Board meeting)
Misc:	\$72.10				
Total:	\$4,041.10	16.20	\$245.00		

<u>CATEGORY</u>	<u>FEES</u>	<u>HOURS BILLED</u>	<u>AVERAGE HOURLY RATE</u>	<u>ATTORNEYS & PARALEGALS EMPLOYED</u>	<u>MAJOR ACTIVITIES</u>
M. O. Y.	\$9,138.50	37.30	\$245.00	Luetkehans (32.10 @ \$245/hr.) (Armstrong 5.20 @245/hr)	various (meetings, review agreements, correspondence, contracts, telephone conferences, and attend Board meeting)
Misc:	\$0.00				
Total:	\$9,138.50	37.30	\$245.00		

<u>CATEGORY</u>	<u>FEES</u>	<u>HOURS BILLED</u>	<u>AVERAGE HOURLY RATE</u>	<u>ATTORNEYS & PARALEGALS EMPLOYED</u>	<u>MAJOR ACTIVITIES</u>
M.O.Y. Land Acquisition	\$4,581.50	18.70	\$245.00	Luetkehans (7.90 @ \$245/hr.) Garner (3.50 @ \$245/hr.) Padilla (7.30 @ \$245/Hr.)	various (meetings, review agreements, correspondence, contracts, telephone conferences, and attend Board meeting)
Misc:	\$37.52				
Misc:	\$ -				
Total:	\$4,619.02	18.70	\$245.00		

<u>CATEGORY</u>	<u>FEES</u>	<u>HOURS BILLED</u>	<u>AVERAGE HOURLY RATE</u>	<u>ATTORNEYS & PARALEGALS EMPLOYED</u>	<u>MAJOR ACTIVITIES</u>
M.O.Y. Construction	\$11,539.50	47.10	\$245.00	Luetkehans (10.40 @ \$245/hr.) Armstrong (16.40@245/hr.) Padilla (2.70 @ \$245/hr.) Gonzales (17.60 @245/hr.)	various (meetings, review agreements, correspondence, contracts, telephone conferences, and attend Board meeting)
Misc:	\$0.00				
Total:	\$11,539.50	47.10	\$245.00		

<u>CATEGORY</u>	<u>FEES</u>	<u>HOURS BILLED</u>	<u>AVERAGE HOURLY RATE</u>	<u>ATTORNEYS & PARALEGALS EMPLOYED</u>	<u>MAJOR ACTIVITIES</u>
Payton Litigation	\$6,566.00	26.80	\$245.00	Luetkehans (10.40 @ \$245/hr.) Armstrong (16.40@245/hr.) Padilla (2.70 @ \$245/hr.) Gonzales (17.60 @245/hr.)	various (meetings, review agreements, correspondence, contracts, telephone conferences, and attend Board meeting)
Misc:	\$347.37				
Total:	\$6,913.37	26.80	\$0.00		

Total of all invoices: \$39,183.16 63.00 \$245.00